



**WATSON  
MARLOW**

Fluid  
Technology  
Solutions

**certa**  
*Plus*

Advancing hygienic  
fluid handling



**masosine**  
Process Pumps





Drawing on considerable experience in sinusoidal pumping technology, Certa Plus has been developed by MasoSine to meet a broad range of applications for the pharmaceutical and personal care industries. These include:

### Applications



**API** – Innovative fluid path design allows for enhanced cleanability using standard CIP or SIP methods while providing reliably gentle pumping action up to 8 million cP.



**Nutraceuticals** – The lowest shear pump means improved quality in Vitamin E and other capsules



**Syrup and sugar solutions** – Continuous pumping action improves the circulation process when thickening the final product. Seal-flush options are available to prevent sugar-based products drying out



**Creams and gels** – Strong suction capability moves high viscosity products from the mixing tank/reactor to the filling line with ease



**Lozenge** – Energy efficient pumping action even tackles high viscosity pastille products. Available jacketing option prevents the product from hardening within the pump if it's stopped



**Suppositories** – Superior handling capability from high and low viscosity supports more efficient processing

### Sine® pump design

A single sinusoidal rotor creates four evenly sized chambers. As each chamber rotates it gently conveys the fluid from the inlet port to the outlet port. At the same time, the opposite chamber opens to draw in more fluid resulting in a smooth flow with virtually no pulsation.

A gate stops fluid flow from the higher pressure outlet to the low pressure inlet.





# Advancing fluid handling

## Cleaner than any lobe or circumferential piston pump

- Type EL Aseptic Class I certification that Certa Plus carries applies to closed equipment, wet clean-in-place (CIP) without dismantling. It is steam sterilisable and bacteria tight. All components are made of FDA and USP Class VI certified raw materials
- USP Class VI, FDA, EHEDG Type EL Class I and EHEDG Type EL I Aseptic Class I
- Removes the risk of residuals after CIP cleaning due to sanitary design
- Reduces the amount of cleaning chemicals used, and cuts the required cleaning cycle time to a minimum
- Self draining
- Modular seal system options:
  - Single mechanical seal
  - Single mechanical seal with flush
  - Double mechanical seal (which can be used with, and without an overpressure system)

## Virtually pulsation free

- Smooth product flow with no need for ancillary dampeners, ensuring product integrity
- Improves flow meter accuracy and heat exchanger efficiency

## Lowest cost of ownership

- Requires up to 50% less power than lobe or circumferential piston pumps
- Extremely simple maintenance performed in-place by operator
- Patented design allows bi-directional running to pump duty fluid back to source
- Certa Plus can be included in aseptic processes without the need of additional steam ports due to bacteria tight design proven by USP Class VI, FDA, EHEDG Type EL Aseptic Class I



## Viscosity handling

- Powerful suction capability up to 12.33 Psi to handle viscous fluids
- Products with viscosities from 1 cP to 8 million cP can be transferred with ease

## Low shear handling for particulates and soft solids

- Improves batch consistency and final product quality
- Low shear action reduces the temperature increase of the pumped liquid to a minimum which is important when circulating products

A space between wet end (pumphead) and power end (bearing housing) of the pump, ensures fluid drains away in the event of a seal failure and eliminates the risk of contamination.



## Sustainability curves

MasoSine Energy Efficiency (Mee) curves demonstrate how the sine principle requires less power to operate in viscous applications. The curves demonstrate clearly how MasoSine pumps help organizations achieve greater sustainability.



Scan the QR code to read more about Mee Curves



# 50%

Certa Plus uses up to 50% less power than lobe and circumferential piston pump types

## Advantages

### Unloading – powerful, flexible, easy-to-clean

Certa Plus pumps have powerful suction capabilities. Their ability to prime even high viscosity products without running into cavitation makes them ideal for quick unloading applications, without causing damage to a system.

### Transfer and circulation – hygienic, gentle, adaptable

Certa Plus is fully CIP proven to USP Class VI, FDA, EHEDG and 3A standards, to avoid any potential product contamination caused by residuals after the cleaning process. The sinusoidal wave rotor design helps to gently transfer valuable pharmaceutical and personal care products with minimal shear to prevent product damage.

### Versatile – robust fluid handling, rapid product changeover

Across applications, varying temperatures result in varying viscosities. For example, in the production of **suppositories**, pumping at lower temperature means an increasing viscosity of the product.

With a seal flush Certa Plus is capable of transferring and handling challenging products from **syrops** and **sugar** solutions to **lozenge products**.

### Meeting the future with up-to-date validation documentation

Certa Plus is rigorously tested to comply with the most up-to-date regulations required.

## Options and accessories

### Connection ports

Certa Plus pumps are available with all standard ports to match your application including DIN, Tri-clamp TC, RJT, and SMS. Customized options are available upon request.

### Port orientations

Pumps can be configured with ports in a range of orientations to meet installation requirements, including a self-draining orientation.

### Accessories

A static and dynamic flush system is available to clean the area behind the seal system. This is even possible with a single mechanical seal.

A jacketing system is available to allow pumps to be heated to the optimal temperature for your process.





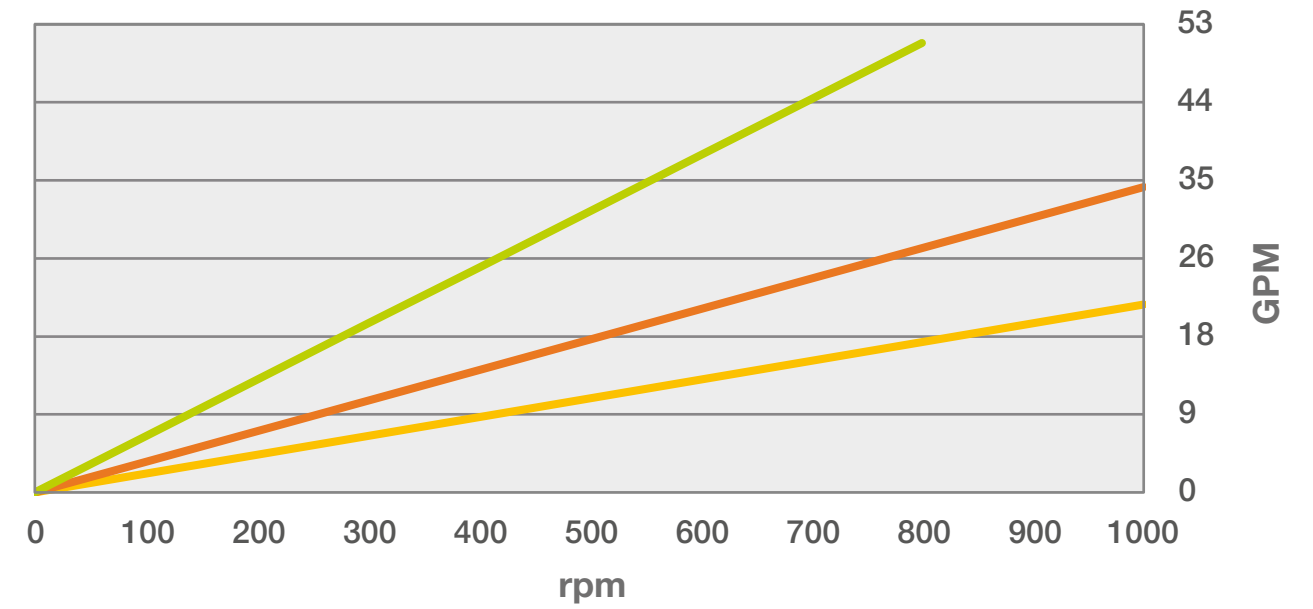

— Certa Plus 100      — Certa Plus 200      — Certa Plus 250

## Customer support

### A network providing comprehensive support globally

- Customer response center
- Localized support
- Spares available from stock locations

### Genuine spares

MasoSine's approved parts policy means that only the highest quality materials are used in the manufacture of our pumps. This gives our customers confidence that our pumps will not let them down.

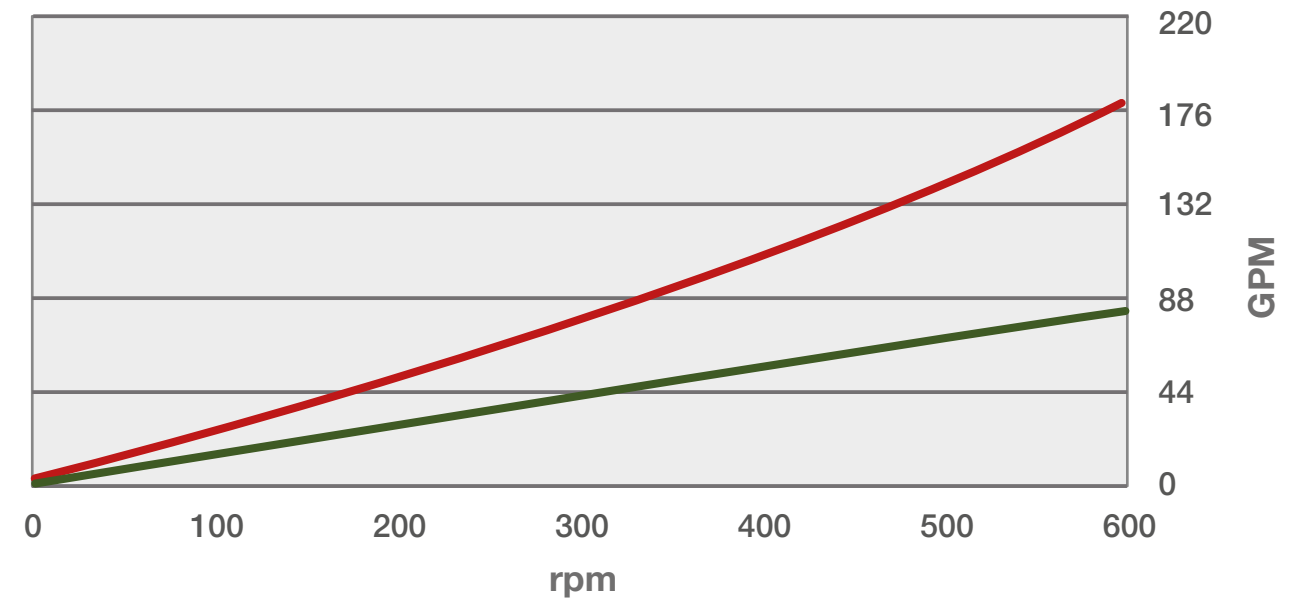

— Certa Plus 300      — Certa Plus 400





## Dimensions

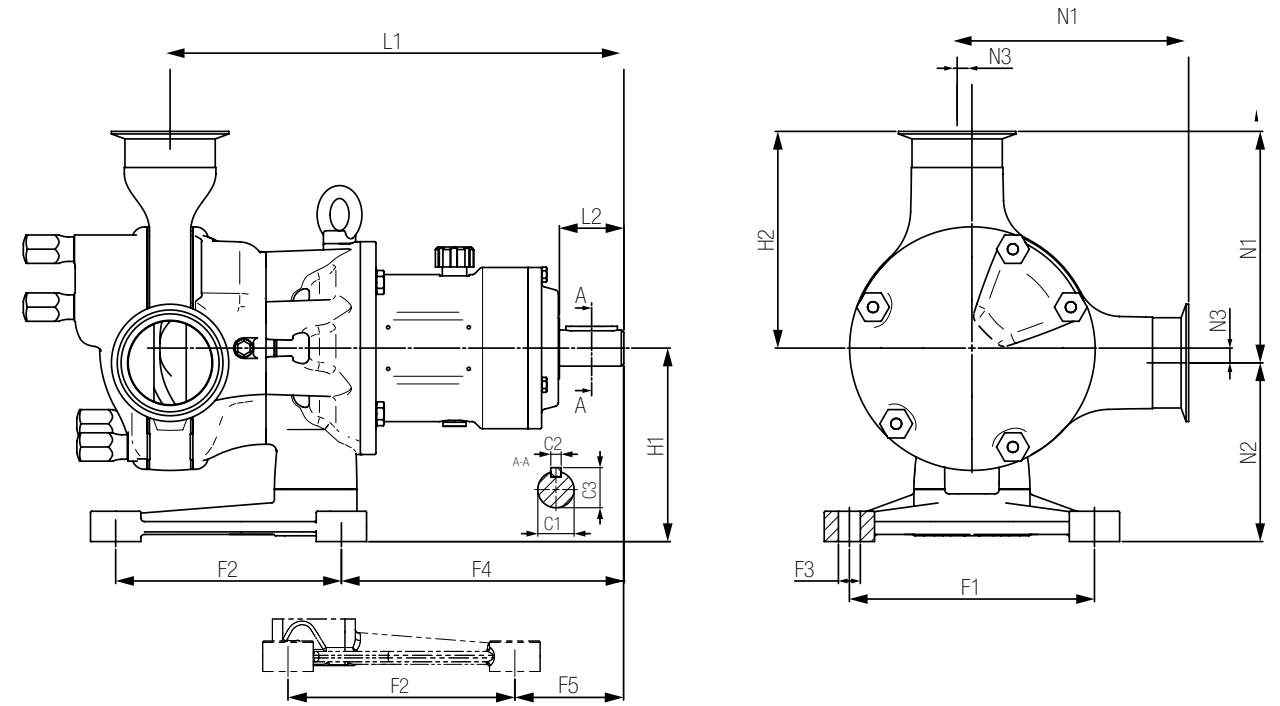

Model	Port	Nozzles			Foot					Length		Height		Coupling		
		N1	N2	N3	F1	F2	F3	F4	F5	L1	L2	H1	H2	C1	C2	C3
	inch	inch	inch	inch	inch	inch	inch	inch	inch	inch	inch	inch	inch	inch	inch	inch
<b>Certa Plus 100</b>	1	5.47	3.35	0.39	4.72	5.31	Ø0.47	5.63	2.24	10.43	1.97	3.74	5.08	Ø1.10	0.31	1.22
<b>Certa Plus 200</b>	2	6.10	3.92	0.39	4.72	5.31	Ø0.47	6.59	3.21	11.75	1.97	4.31	5.71	Ø1.10	0.31	1.22
<b>Certa Plus 250</b>	2.5	7.54	5.45	0.45	7.48	6.89	Ø0.67	8.62	3.31	13.86	1.97	5.91	7.09	Ø1.10	0.31	1.22
<b>Certa Plus 300</b>	3	9.35	6.00	0.69	9.84	8.46	Ø0.79	11.22	6.06	17.93	3.15	6.69	8.66	Ø1.97	0.55	2.11
<b>Certa Plus 400</b>	4	12.74	6.65	1.22	10.49	10.00	Ø0.83	11.83	6.65	20.22	3.03	7.87	11.52	Ø1.97	0.55	2.11

## Technical data

Model	Maximum particle size	Volume per revolution	Speed	Maximum flow	Maximum pressure	Maximum temperature
	inch	gallons	rpm	US gal/min	psi	F
<b>Certa Plus 100</b>	0.51	0.021	1000	21.1	87	212
<b>Certa Plus 200</b>	0.71	0.034	1000	34.2	87	212
<b>Certa Plus 250</b>	0.87	0.063	800	50.5	87	212
<b>Certa Plus 300</b>	1.18	0.132	600	78.9	87	212
<b>Certa Plus 400</b>	1.50	0.305	600	183.2	87	212

BIOTECHNOLOGY AND PHARMACEUTICAL SOLUTIONS



**Watson-Marlow Fluid Technology Solutions**

Watson-Marlow Fluid Technology Solutions supports its customers locally through an extensive global network of direct sales operations and distributors

[wmfts.com/global](http://wmfts.com/global)

