

Qdos CWT

Qdos metering pump

Features and benefits

- Flow rates from 0.1 to 500 ml/min (0.001 to 7.93 USGPH) at up to 9 bar (130 psi)
- Simple drop-in installation eliminates ancillary equipment
- Reduced maintenance with single, no-tools, component replacement
- Cost of ownership is less than that of a diaphragm pump
- Cut chemical cost through higher accuracy metering
- No backpressure valves, pulsation dampener, degassing valves, foot valves, strainers or float switches



Qdos CWT performance

Qdos® CWT™		Qdos® CWT™ remote	
Speed (rpm)	Flow ml/min (USGPH)*	Speed (rpm)	Flow ml/min(USGPH)*
0.025-125	0.1-500 (0.001-7.93)	0.078-125	0.3-500 (0.005-7.93)
*accuracy ±1%, repeatability ±0.5%			
*Flow rates can be affected by discharge pressure			

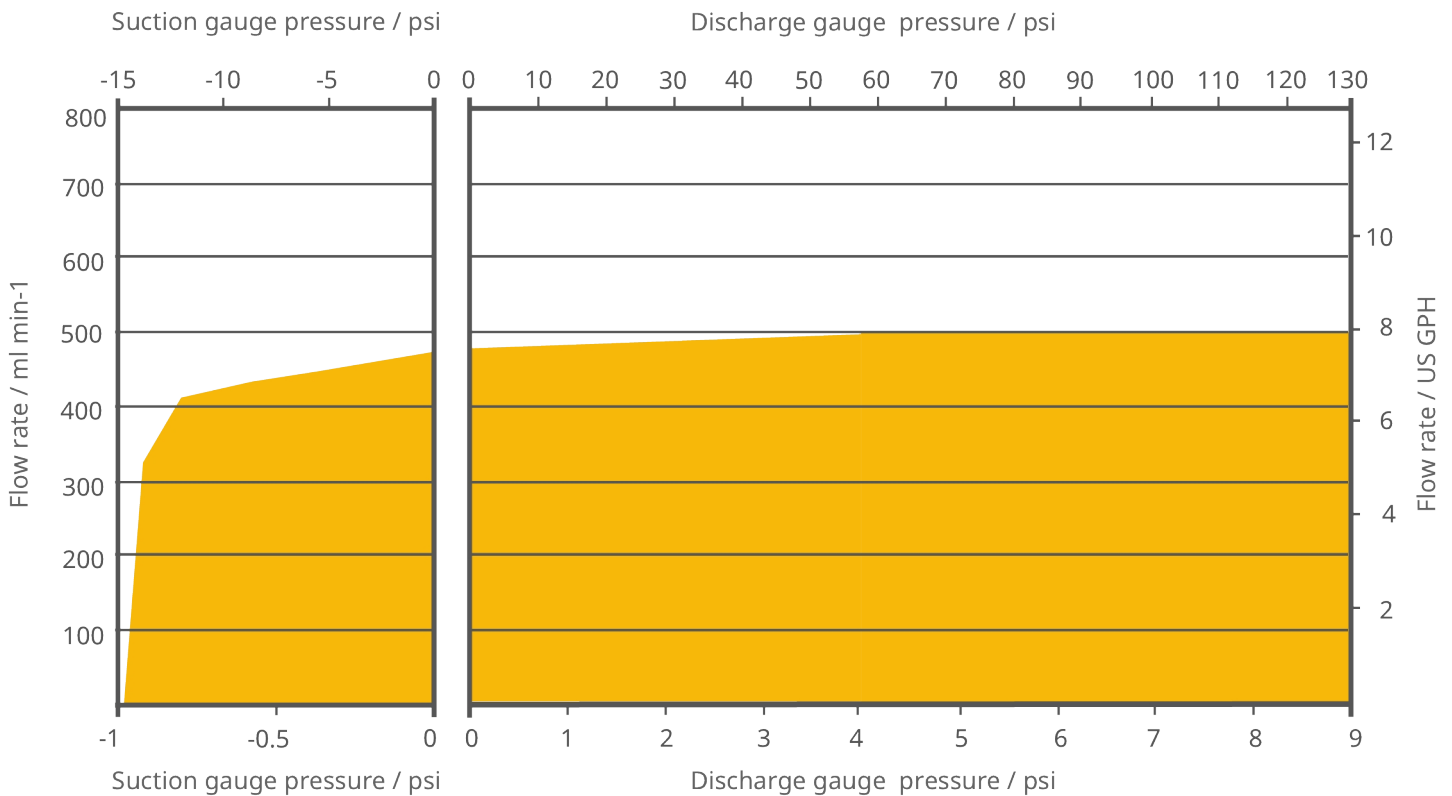

Technical specifications

	Qdos CWT
Max. flow rate	500 ml/min
Min. flow rate	0.1 ml/min
Max. flow rate	7.93 USGPH
Min. flow rate	0.001 USGPH
Max. operating pressure	9 bar
Max. operating pressure	130 psi
Max. operating speed	125 rpm
Ambient Temperature Range	5 – 40 °C
Ambient Temperature Range	41 – 104 °F
Weight	6.8 kg
Weight	15 lbs
Control types	Manual, PROFIBUS®, Remote, Universal, Universal relay, Universal+, Universal+ relay
Standards	CE, cETLus, CSA, C-Tick, IRAM S Mark, NSF 61
Drive standards	CE, cETLus, CSA, C-Tick, IRAM S Mark, NSF 61
Drive ingress protection	IP66, NEMA 4X
Drive humidity	80% up to 31°C, 88°F, decreasing linearly to 50% at 40°C, 104°F
Noise	< 70dB(A) at 1m
Max. altitude	2000 m
Power supply	100 to 240 VAC 50 to 60 Hz 190 VA, 12 to 24 V DC
Drive power supply	100 to 240 VAC 50 to 60 Hz 190 VA, 12 to 24 V DC

Minimum and maximum flow depends upon pumphead, flow unit and method of control. Pressure and speed depends on pumphead chosen.

Materials of construction

	Qdos CWT
Bearings	Steel
Driveshaft	Stainless steel 440C
Drive casework	20% glass filled PPE/PS
Fluid connectors	Polypropylene, PVDF
Drive keypad/HMI	Polyester
Lubricant	PFPE based
Pumphead body assembly	40% glass filled PPS
Pumphead rotor assembly	Stainless steel
Fluid contact element	EPDM, PEEK, PP
Fluid connection port	Polypropylene
Fluid connection seals	Santoprene
Pumphead enclosure seal	EPDM, NBR
Rotor	Stainless steel 303

Qdos CWT dimensions

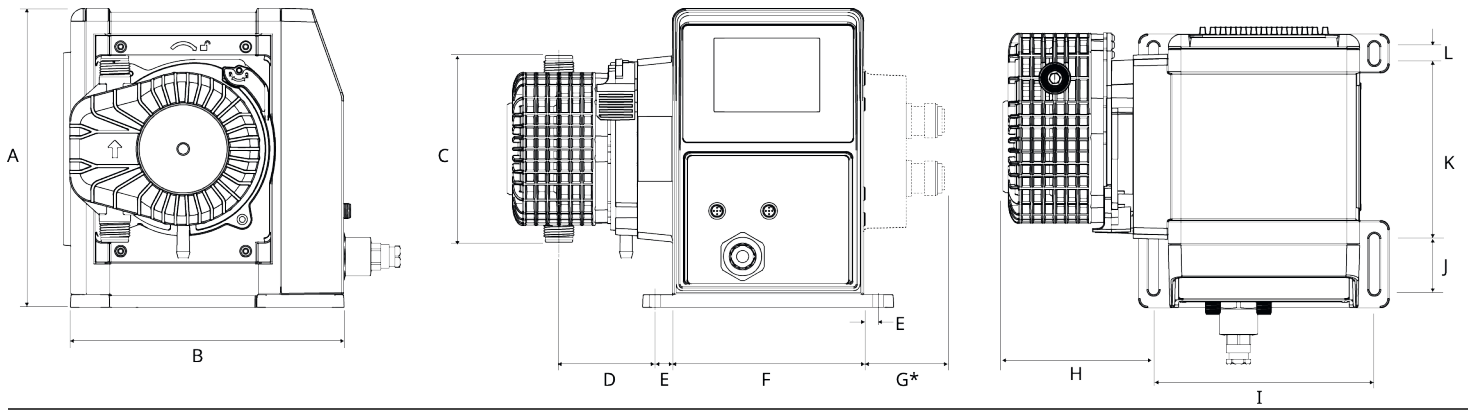

A	B	C	D	E	F	G*	H	I	J	K	L
234 mm (9.2")	214 mm (8.4")	146 mm (5.8")	77.4 mm (3.1")	11.5 mm (0.5")	150 mm (5.9")	43 mm (1.7")	117.9 mm (4.6")	173 mm (6.8")	40 mm (1.6")	140 mm (5.5")	10 mm (0.4")

*Optional relay module

Control options

Operational modes	Manual	Remote	PROFIBUS	Universal	Universal+
Manual	✓		✓	✓	✓
PROFIBUS—bus speed 9.6–1,500 kb/s			✓		
Contact				✓	✓
4-20mA		✓		✓	✓
Fault reporting	✓	✓	✓	✓	✓

Features	Manual	Remote	PROFIBUS	Universal	Universal+
Numerical flow display	✓		✓	✓	✓
Numerical speed display	✓		✓	✓	✓
Fluid level monitor	✓		✓	✓	✓
Max (prime)	✓		✓	✓	✓
Auto restart (after power restored)	✓	✓	✓	✓	✓
Fluid recovery	✓		✓	✓	✓
Leak detection	✓	✓	✓	✓	✓
3.5" (88.9mm) colour TFT display	✓		✓	✓	✓
LED Pump status icons		✓			

Control methods	Manual	Remote	PROFIBUS	Universal	Universal+
Input/Output Options		L	L	L or R	L or R
Manual control capability	✓		✓	✓	✓
4-20mA input		✓		✓	✓
4-20mA input two point calibration					✓
4-20mA output		✓			✓
Contact input (pulse/batch)				L or R	L or R
Manual speed adjustment range	3333:1 (Qdos 20) 5000:1 (Qdos 30) 10000:1 (Qdos 60) 20000:1 (Qdos 120)		3333:1 (Qdos 20) 5000:1 (Qdos 30) 10000:1 (Qdos 60) 20000:1 (Qdos 120)	3333:1 (Qdos 20) 5000:1 (Qdos 30) 10000:1 (Qdos 60) 20000:1 (Qdos 120)	3333:1 (Qdos 20) 5000:1 (Qdos 30) 10000:1 (Qdos 60) 20000:1 (Qdos 120)
Minimum motor adjustment speed increment (Dependent upon the operating mode and chosen flow unit)	0.006	0.078	0.100	0.003	0.003
4-20mA resolution		1600:1		1600:1	1600:1
Profibus speed resolution			550:1 (Qdos 20) 1250:1 (Qdos 30) 1250:1 Qdos 60 1400:1 (Qdos 120)		
Run stop input		✓		✓	✓
Run status output		✓		✓	L
Alarm output		✓		✓	L
Four configurable relay outputs					R
Remote fluid recovery		✓		R	R

PROFIBUS	Manual	Remote	PROFIBUS	Universal	Universal+
Speed set point			✓		
Speed feedback			✓		
Flow calibration function			✓		
Hours run			✓		
Revolution counter			✓		
Leak detection			✓		
Low fluid level alarm			✓		
Diagnostic feedback			✓		

Security	Manual	Remote	PROFIBUS	Universal	Universal+
Keypad lock	✓		✓	✓	✓
PIN lock to protect set up	✓		✓	✓	✓

*Control options - Universal and Universal+ models		
Variant	Standard pump (L)	Relay Module (R)
Input	5-24V DC	5-24V DC or 110V AC
Output	Open collector	Contact rating 110V AC, 4A 30V DC, 4A

Product codes

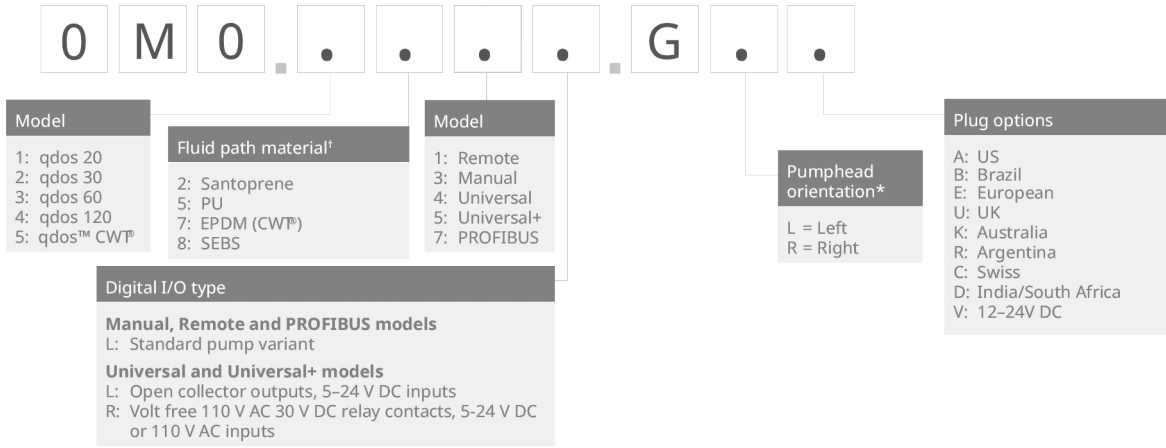

† For guidance on chemical compatibility see www.qdospumps.com

* The pumphead side location is required when ordering. The left/right perspective assumes the user is looking at the front of the pump. The pump in the dimensions diagram is considered a pumphead located to the left.

Description	Partcode
CWT 30 pumphead EPDM/PEEK/PFPE 9 bar (130 psi)	0M3.5700.PFP

Disclaimer: All flow rates shown were obtained pumping water at 20 °C (68 °F) with zero suction and delivery heads. qdos drives are not ATEX rated and should not be used within explosive atmospheres. The information contained in this document is believed to be correct but Watson-Marlow Limited accepts no liability for any errors it contains and reserves the right to alter specifications without notice. It is the users responsibility to ensure product suitability for use within their application. Watson-Marlow, Qdos, ReNu, LoadSure, Bioprene, Pumpsil and Marprene are trademarks of Watson-Marlow Limited. STA-PURE PFL® and STA-PURE PCS® are registered trademarks of W.L Gore & Associates Inc. Please state the product code when ordering pumps and tubing.

wmfts.com/global



11 June 2024