

Disc

The disc inserted in the front cover contains the user manual of the models **DuCoNite®** 25 and **DuCoNite®** 32. The disc also contains a replacement instruction for the pump hose. This replacement instruction is only for users that are familiar with the replacement procedures in the user manual.

How to use the disc

- 1 Put the disc in the disc drive.
- 2 Close the disc drive.
The disc will start automatically.
- 3 Wait until the various language versions appear on screen.
- 4 Select the required language (click 1x with the left mouse button).
The PDF reader program will automatically start and the required user manual appears on screen.

Shortcuts

In the left margin you will find the various chapters and paragraphs. These can be accessed directly by clicking on the required chapter or paragraph.

In the text you will find hyperlinks to chapters or paragraphs. These hyperlinks are linked with the required chapters or paragraphs. By clicking a shortcut the required chapter or paragraph appears on screen.

System requirements

The program on the disc requires a PC with the following minimum system requirements:

- Disc drive

The following software must be installed on the PC:

- PDF reader program
- An Internet browser

Hose pump series DuCoNite[®] 25 and DuCoNite[®] 32

Manual

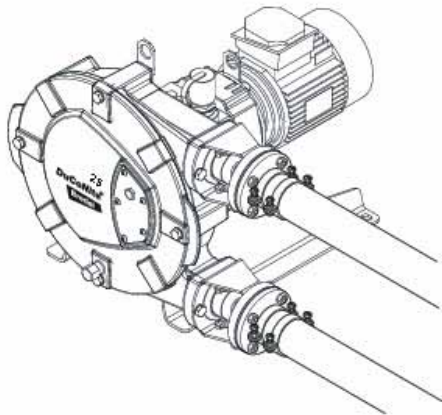

© 2013 Watson-Marlow Bredel B.V.

All rights reserved.

The information provided herein may not be reproduced and/or published in any form, by print, photoprint, microfilm or any other means whatsoever (electronically or mechanically) without the prior written authorisation of Watson-Marlow Bredel B.V.

The information provided can be changed without prior notification. Watson-Marlow Bredel B.V. or one of its representatives cannot be held liable for possible damage resulting from use of this manual. This is an extensive limitation of the liability which applies to all damage, inclusive of (without limitation) compensating, direct, indirect or consequential damage, loss of data, income or profit, loss or damage to possessions and claims of third parties.

Watson-Marlow Bredel B.V. provides the information in this manual "as is" and does not take any responsibility and does not give any guarantee on this manual or its content. Watson-Marlow Bredel B.V. rejects all responsibilities and guarantees. Furthermore, Watson-Marlow Bredel B.V. does not take responsibility for and does not guarantee that the information in this manual is accurate, complete or up to date.

Names, trade names, brands, etc. used by Watson-Marlow Bredel B.V. may not, as per the legislation concerning the protection of trade names, be considered as available.

CONTENTS**1 GENERAL**

| | | |
|-----|--|---|
| 1.1 | <i>How to use this manual</i> | 8 |
| 1.2 | <i>Original instructions</i> | 8 |
| 1.3 | <i>Other supplied documentation</i> | 8 |
| 1.4 | <i>Service and support</i> | 8 |
| 1.5 | <i>Environment and disposal of waste</i> | 9 |

2 SAFETY

| | | |
|-----|---|----|
| 2.1 | <i>Symbols</i> | 10 |
| 2.2 | <i>Intended use</i> | 10 |
| 2.3 | <i>Use in potentially explosive atmospheres</i> | 11 |
| 2.4 | <i>Use in corrosive atmosphere</i> | 11 |
| 2.5 | <i>Responsibility</i> | 11 |
| 2.6 | <i>Qualification of the user</i> | 12 |
| 2.7 | <i>Regulations and instructions</i> | 12 |

3 WARRANTIES**4 DESCRIPTION**

| | | |
|-------|---|----|
| 4.1 | <i>Identification of the product</i> | 14 |
| 4.1.1 | <i>Identification of the product</i> | 14 |
| 4.1.2 | <i>Identification of the pump</i> | 14 |
| 4.1.3 | <i>Identification of the gearbox</i> | 14 |
| 4.1.4 | <i>Identification of the electric motor</i> | 15 |
| 4.1.5 | <i>Identification of the frequency controller</i> | 15 |
| 4.1.6 | <i>Identification of the pump hose</i> | 15 |
| 4.2 | <i>Construction of the pump</i> | 16 |
| 4.3 | <i>Operation of the pump</i> | 16 |
| 4.4 | <i>Pump hose</i> | 18 |
| 4.4.1 | <i>General</i> | 18 |
| 4.4.2 | <i>Hose compression force adjustment (shimming)</i> | 19 |
| 4.4.3 | <i>Lubrication and cooling</i> | 19 |
| 4.5 | <i>Gearbox</i> | 19 |
| 4.6 | <i>Electric motor</i> | 20 |
| 4.7 | <i>Motor frequency controller</i> | 20 |
| 4.8 | <i>Available options</i> | 20 |

5 INSTALLATION

| | | |
|-------|--|----|
| 5.1 | <i>Unpacking</i> | 21 |
| 5.2 | <i>Inspection</i> | 21 |
| 5.3 | <i>Installation conditions</i> | 21 |
| 5.3.1 | Ambient conditions | 21 |
| 5.3.2 | Set-up | 21 |
| 5.3.3 | Pipework | 22 |
| 5.3.4 | Variable Frequency Drive | 23 |
| 5.3.5 | High Level Control (HLC) | 24 |
| 5.4 | <i>Lifting and moving the pump</i> | 25 |
| 5.5 | <i>Placing the pump</i> | 25 |

6 COMMISSIONING

| | | |
|-----|----------------------------|----|
| 6.1 | <i>Preparations</i> | 26 |
| 6.2 | <i>Commissioning</i> | 27 |

7 MAINTENANCE

| | | |
|--------|---|----|
| 7.1 | <i>General</i> | 28 |
| 7.2 | <i>Maintenance and periodic inspections</i> | 28 |
| 7.3 | <i>Additional maintenance in potentially explosive environments</i> | 30 |
| 7.4 | <i>Cleaning the pump hose</i> | 30 |
| 7.5 | <i>Changing lubricant</i> | 31 |
| 7.6 | <i>Changing oil in gearbox</i> | 32 |
| 7.7 | <i>Replacing pump hose</i> | 33 |
| 7.7.1 | Removing pump hose | 33 |
| 7.7.2 | Cleaning the pump head | 35 |
| 7.7.3 | Fitting the pump hose | 36 |
| 7.8 | <i>Exchanging replacement parts</i> | 39 |
| 7.8.1 | Replacing pressing shoes | 39 |
| 7.8.2 | Replacing seal ring and bearings | 41 |
| 7.9 | <i>Adjusting hose compression force (shimming)</i> | 44 |
| 7.10 | <i>Options</i> | 47 |
| 7.10.1 | Revolution counter | 47 |
| 7.10.2 | Drain connection | 48 |

8 STORAGE

| | | |
|-----|------------------------|----|
| 8.1 | <i>Hose pump</i> | 49 |
| 8.2 | <i>Pump hose</i> | 49 |

9 TROUBLESHOOTING**10 SPECIFICATIONS**

| | |
|--|----|
| <i>10.1 Pump head</i> | 55 |
| 10.1.1 Performance | 55 |
| 10.1.2 Materials | 56 |
| 10.1.3 Surface treatment | 57 |
| 10.1.4 Chemical resistance chart DuCoNite® coating | 57 |
| 10.1.5 Lubricant table pump | 58 |
| 10.1.6 Weights | 58 |
| 10.1.7 Torque figures | 60 |
| 10.1.8 Shims specifications | 62 |
| <i>10.2 Lubricant table gearbox</i> | 63 |
| <i>10.3 Gearbox</i> | 64 |
| <i>10.4 Electric motor</i> | 65 |
| <i>10.5 Frequency controller</i> | 65 |
| <i>10.6 Parts list</i> | 66 |
| 10.6.1 Overview | 66 |
| 10.6.2 Cover assembly | 67 |
| 10.6.3 Rotor assembly | 68 |
| 10.6.4 Pump housing assembly | 69 |
| 10.6.5 Support assembly | 71 |
| 10.6.6 Flange assembly | 72 |
| 10.6.7 Revolution counter assembly | 73 |
| 10.6.8 Lubricants | 73 |

SAFETY FORM**NOTES**

1 GENERAL

1.1 How to use this manual

This manual is intended as a reference book by means of which qualified users are able to install, commission and maintain the hose pumps mentioned on the front cover.

1.2 Original instructions

The original instructions for this manual have been written in English. Other language versions of this manual are a translation of the original instructions.

1.3 Other supplied documentation

Documentation of components such as electric motors, gearboxes, etc. is normally not included in this manual. But if additional documentation is supplied, you must follow the instructions in this additional documentation.

1.4 Service and support

For information with respect to specific adjustments, installation, maintenance or repair jobs which fall beyond the scope of this manual, contact your Bredel representative. Make sure you have the following data at hand:

- Serial number hose pump
- Article number pump hose
- Article number gearbox
- Article number electric motor
- Article number frequency controller

You will find these data on the identification plates or stickers of the pumphead, the pump hose, the gearbox and the electric motor. Refer to § 4.1.1.

1.5 Environment and disposal of waste

**CAUTION**

Always observe the local rules and regulations with respect to processing (non reusable) parts of the hose pump.

Inquire within your local government about the possibilities for reuse or environment-friendly processing of packaging materials, (contaminated) lubricant and oil.

2 SAFETY

2.1 Symbols

In this manual the following symbols are used:

| | |
|--|--|
|  | WARNING Procedures which, if not carried out with the necessary care, may result in serious damage to the hose pump or in serious bodily harm. |
|--|--|

| | |
|--|---|
|  | CAUTION Procedures which, if not carried out with the necessary care, may result in serious damage to the hose pump, the surrounding area or the environment. |
|--|---|

| | |
|---|----------------------------------|
|  | Remarks, suggestions and advice. |
|---|----------------------------------|

2.2 Intended use

The hose pump is exclusively designed for pumping suitable products. Every other or further use is not in conformance with the intended use.

The "Intended use" as laid down in EN 292-1 is "... the use for which the technical product is intended in accordance with the specifications of the manufacturer, inclusive of his indications in the sales brochure". In case of doubt it is the use which appears to be its intended use judging from the construction, execution and function of the product. Observing the instructions in the user's documentation also belongs to intended use.

Only use the pump in accordance with the intended use described above. The manufacturer cannot be held responsible for damage or harm resulting from misuse. If you want to change the application of your hose pump, contact your Bredel representative first.

2.3 Use in potentially explosive atmospheres

The *pump head* and *gearbox* mentioned in this manual are suitable for use in a potentially explosive atmosphere. The pumps mentioned meet the requirements as stated in the European Directive 94/9/EC (ATEX Directive).

The pumps belong to:

- Group II Appliances, category 2 GD ck T4

2.4 Use in corrosive atmosphere

The **DuCoNite**[®] pump head is coated (both in- and externally) with a corrosion and wear resistant coating. This coating withstands highly oxidising and reducing media. Refer to § 10.1.4 for a specification.

2.5 Responsibility

The manufacturer does not accept any responsibility for damage or harm caused by not (strictly) observing the safety regulations and instructions in this manual and the also supplied documentation, or by negligence during installation, use, maintenance and repair of the hose pumps mentioned on the front cover. Depending on the specific working conditions or accessories used, additional safety instructions can be required.

Immediately contact your Bredel representative, if you noticed a potential danger while using your hose pump.

**WARNING**

The user of the hose pump is always fully responsible for observing the local valid safety regulations and directives. Observe these safety regulations and directives when using the hose pump.

2.6 Qualification of the user

The installation, use and maintenance of the hose pump should only be performed by well-trained and qualified users. Temporary staff and persons in training may use the hose pump only under the supervision and responsibility of trained and qualified users.

2.7 Regulations and instructions

- Everyone who works with the hose pump must be aware of the contents of this manual and observe the instructions with great care.
- Never change the order of the actions to be carried out.
- Always store the manual near the hose pump.

3 WARRANTIES

The manufacturer offers a two-year warranty on proper workmanship of all parts of the hose pump. Exclusion is made for normal wear and tear of consumables such as pump hoses, lubricant, hose clamps, pressing shoes, ball bearings, wear rings, seals and rubber bushes, or parts which have been misused or damaged through negligence.

This manufacturer's warranty is null and void for any user who has substituted the parts of an alternate manufacturer into a Watson-Marlow Bredel (hereafter called Bredel) hose pump.

Damaged parts may be returned to the manufacturer for warranty analysis. If failure was determined caused by faulty workmanship, the manufacturer will repair or replace the faulty component.

The parts must be accompanied by a fully completed and signed health and safety form, as present in the back of this manual. The form must be applied to the outside of the shipping carton.

Parts which have been contaminated or which have been corroded by chemicals or other substances that can pose a health risk must be cleaned before they are returned to the manufacturer. Furthermore, it should be indicated on the health and safety form, which specific cleaning procedure has been followed, and it should be indicated that the equipment has been decontaminated. The safety form is required at all items, even if the parts have not been used.

Warranties purporting to be on behalf of Bredel made by any person, including representatives of Bredel, its subsidiaries, or its distributors, which do not accord with the terms of this warranty shall not be binding upon Bredel, unless expressly approved in writing by a Director or Manager of Bredel.

4 DESCRIPTION

4.1 Identification of the product

4.1.1 Identification of the product

The hose pump can be identified based on the identification plates or stickers on:

- A:** Pump head
- B:** Gearbox
- C:** Electric motor
- D:** Pump hose
- E:** Frequency controller (option)

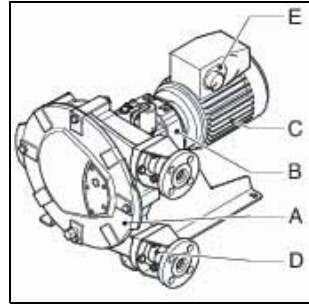

4.1.2 Identification of the pump

The identification plate on the pump head contains the following data:

- A:** Pump model
- B:** Serial number

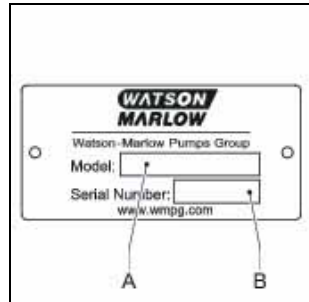

4.1.3 Identification of the gearbox

The identification plate on the gearbox contains the following data:

- A:** Article number
- B:** Serial number
- C:** Type number
- D:** Reduction ratio
- E:** Number of revolutions per minute

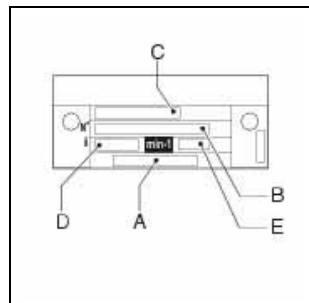

4.1.4 Identification of the electric motor

The identification plate on the electric motor contains the following data:

- A:** Type number
- B:** Serial number
- C:** Article number
- D:** Mains
- E:** Frequency
- F:** Speed
- G:** Power
- H:** Power factor
- I:** Current

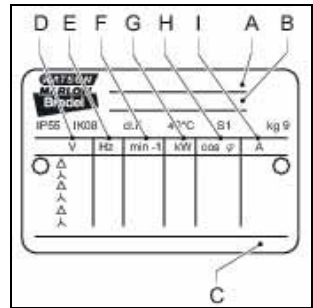

4.1.5 Identification of the frequency controller

The identification of the Bredel Variable Frequency Drive (VFD) can be found inside the VFD. Remove the cover by loosening the two screws. The identification sticker contains the following data:

- A:** Article number
- B:** Serial number

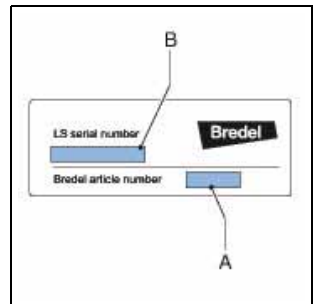

4.1.6 Identification of the pump hose

The identification sticker on the pump hose contains the following data:

- A:** Pump type
- B:** Reorder number
- C:** Internal diameter
- D:** Type of material of inner liner
- E:** Remarks, if applicable
- F:** Maximum permissible working pressure
- G:** Production code

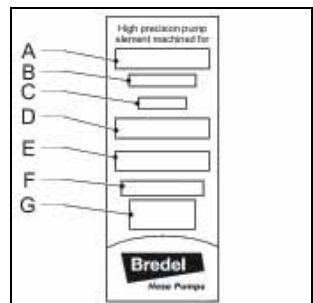

4.2 Construction of the pump

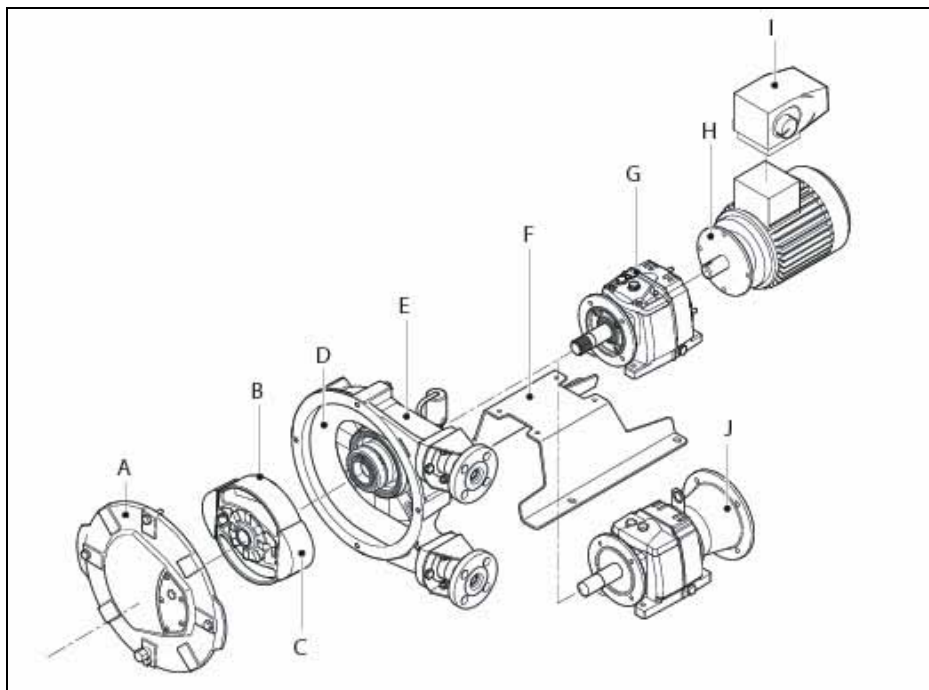

- A: Cover
- B: Rotor
- C: Pressing shoes
- D: Pump hose
- E: Pump housing
- F: Support
- G: Gearbox
- H: Electric motor
- I: Frequency controller (option)
- J: Adapter without motor (option)

4.3 Operation of the pump

The heart of the pump head consists of a specially constructed pump hose (A) which lies contorted against the inside of the pump housing (B). Both ends of the

hose are connected to the suction and discharge lines by means of a flange construction (C). A bearing-mounted rotor (D) with two facing pressing shoes (E) is in the center of the pump head.

In phase 1 the lower pressing shoe compresses the pump hose by the rotational movement of the rotor, forcing the fluid through the hose. As soon as the pressing shoe has passed, the hose recovers to its original shape due to the mechanical properties of the material.

In phase 2 the product is drawn into the hose by the (continuous) turning motion of the rotor.

In phase 3, the second pressing shoe will subsequently compress the pump hose. Due to the continuous rotating movement of the rotor not only new product is sucked in, but also the already present product is pressed out by the pressing shoe. When the first pressing shoe runs from the pump hose, the second pressing shoe has already closed the pump hose and the product is prevented from flowing back. This method of liquid displacement is also known as the "positive displacement principle".

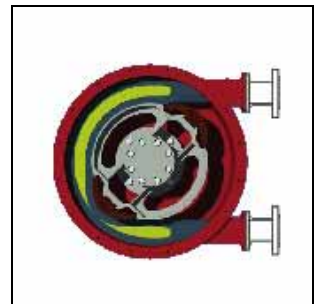
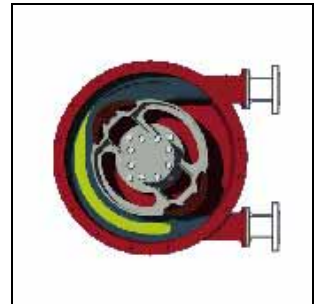
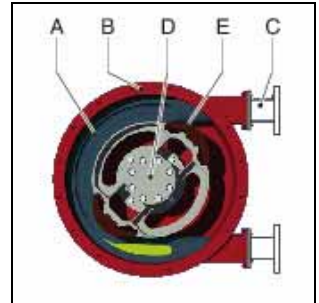

4.4 Pump hose

4.4.1 General

- A:** Outer extruded layer made of natural rubber
B: Four nylon reinforcement layers
C: Inner extruded liner

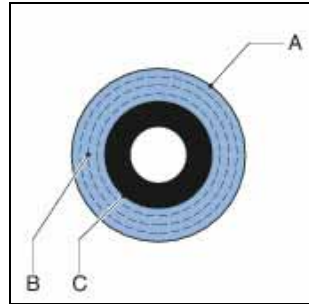

The pump hose liner material should be chemically resistant with the product to be pumped. Dependent on the specific requirements of your application a corresponding pump hose must be selected. For each pump model various hose types are available.

The material of the inner liner of the pump hose determines the hose type. Each hose type is marked by a unique color code.

| Hose type | Material | Color code |
|-----------|----------------|------------|
| NR | Natural rubber | Purple |
| NBR | Nitrile rubber | Yellow |
| EPDM | EPDM | Red |
| CSM | CSM | Blue |

| | |
|----------|---|
| i | Consult your Bredel representative for more detailed information about the chemical and temperature resistance of pump hoses. |
|----------|---|

The Bredel pump hoses have been carefully machined, therefore there are minimum tolerances in wall thickness. It is very important to guarantee the correct compression of the pump hose, because:

- When the compression is too high, it creates a too high load of the pump and pump hose, which may result in a reduction of the life of the pump hose and bearings.

- When the compression is too low, this will result in loss of capacity and backflow. Backflow results in a reduction of the life of the pump hose.

4.4.2 Hose compression force adjustment (shimming)

In order to achieve optimal life of the pump hose, the compression force of the pump hose can be adjusted by placing a number of shims under the pressing shoes. The shims (A) are fitted between the rotor (B) and the pressing shoe (C). The number of shims will vary for each counterpressure situation.

The paragraph 7.9 describes how to select and install the shims.

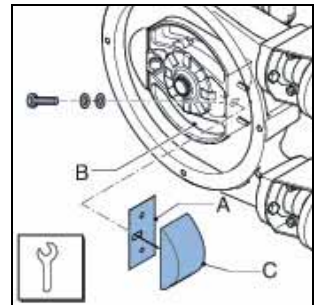

4.4.3 Lubrication and cooling

The pump head, in which the rotor and pump hose can be found, is filled with Bredel Genuine Hose Lubricant. This lubricant lubricates the movement between the hose and the pressing shoes and dissipates the generated heat via the pump housing and the cover.

The lubricant is food grade. See § 10.1.5 for the required quantity and NSF registration.



Consult your Bredel representative for lubrication recommendations when operating the hose pump below 2 rpm.

4.5 Gearbox

The hose pump types described in this manual use co-axial gearbox units.

The gearboxes are fitted with a foot rest. The outgoing shaft has been fitted with a spline.

4.6 Electric motor

If the electric motor has been standard supplied by the manufacturer, it is an integrated standardized squirrel-cage motor. Refer to § 10.4 for specifications. If the pump is to be used in potentially explosive atmospheres, contact your Bredel representative.

4.7 Motor frequency controller

Refer to the also supplied documentation of the supplier and § 10.5. If the pump is to be used in potentially explosive atmospheres, contact your Bredel representative.

4.8 Available options

The next options are available for the hose pump:

- Revolution counter
- Drain connection
- Epoxy / titanium pressing shoes and titanium shims
- Frequency controller
- Pump support for non-standard gearbox types
- Special configuration for use in potentially explosive atmospheres

**WARNING**

If the pump is to be used in potentially explosive atmospheres, contact your Bredel representative.

5 INSTALLATION

5.1 Unpacking

When unpacking carefully follow the instructions as given on the packaging or on the hose pump.

5.2 Inspection

Check that your delivery is correct and check it for any transport damage. Refer to § 4.1.1. Report any damage immediately to your Bredel representative.

5.3 Installation conditions

5.3.1 Ambient conditions

Make sure that the hose pump is in an area where the ambient temperature during operation is not lower than -20 °C (-4 °F) and not higher than +45 °C (+113 °F).

5.3.2 Set-up

- The pump materials and protective layers are suitable for indoor set-up and a protected outdoor set-up. Under certain conditions the pump is suitable for limited outdoor set-up or a salty or aggressive atmosphere. Consult your Bredel representative for more information.
- Make sure that the floor surface has a maximum slope of 10 mm per meter (0.12 inch per foot).
- Make sure that there is sufficient room around the pump to carry out the necessary maintenance.
- Make sure that the room is sufficiently ventilated, so that the heat developed by the pump and drive can be dissipated. Keep some distance between the ventilation cover of the electric motor and the wall to allow the supply of cooling air.

5.3.3 Pipework

When determining and connecting suction and discharge lines consider the following points:

- The bore size of the suction and discharge lines must be larger than the bore size of the pump hose. For more information consult your Bredel representative.
- Limit the presence of sharp bends in the discharge line. Make sure that the radius of the bent discharge line is as large as possible (preferably 5S). It is recommended to use Y-connections instead of T-connections.
- It is recommended to use a minimum of three quarters (3/4) of the hose length as flexible hose in the suction or discharge line. This avoids the need to remove the connection lines when changing a pump hose.
- Keep the delivery and suction lines as short and direct as possible.
- Select the correct mounting material for flexible hoses and make sure that the installation is suited for the design pressure of the system.
- Prevent any possibilities of exceeding the maximum working pressure of the hose pump. Refer to § 10.1.1. If necessary fit a pressure relief valve.

**CAUTION**

Consider the maximum permissible working pressure on the discharge side. Exceeding the maximum working pressure may lead to serious damage to the pump.

- Make sure that the maximum forces on the flanges are not exceeded. The permissible loads are given in the following table.

Maximum permissible loads on the pump flange

| Force | Unit | DuCoNite® | DuCoNite® |
|-------|------|-----------|-----------|
| | | 25 | 32 |
| F1 | N | 600 | 600 |
| | lbf | 135 | 135 |
| F2 | N | 500 | 500 |
| | lbf | 112 | 112 |
| F3 | N | 200 | 200 |
| | lbf | 45 | 45 |

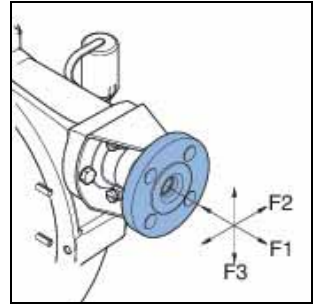

CAUTION

In case of hose failure, the product or a mixture of product and lubricant can leak by the breather cap. If this risk is not acceptable, drain piping can be connected, refer to § 7.10.2.



WARNING

The maximum pump temperature is 140 °F. Above this temperature the corrosion speed can rise excessively, depending on the product.

5.3.4 Variable Frequency Drive



WARNING

A Bredel VFD that is fitted *without the control switch* starts automatically when power is applied.

If the hose pump is fitted with a Bredel Variable Frequency Drive (VFD), consider the following points:

- Take precautions so the motor does not re-start automatically after an unscheduled stop.

In the event of a power or mechanical failure, the Bredel VFD controls the motor to stop. When the cause of the failure is removed, the motor can restart automatically. The automatic restart is dangerous to certain installations of the pump.

- All control cables outside the enclosure must be shielded and have a cross sectional area between 0.22 and 1 mm² (23 and 18 AWG). The shielding must be connected to earth at both ends.

5.3.5 High Level Control (HLC)

To sense the lubricant level inside the pump housing the pump is provisioned with a floater. The HLC floater (A) is positioned above the normal lubricant level of the pump. When a hose fails, the product will be pressed into the pump casing and causes a level rise of the lubricant. The HLC shall detect this rise of lubricant. After hose failure, the floater needs to be cleaned.

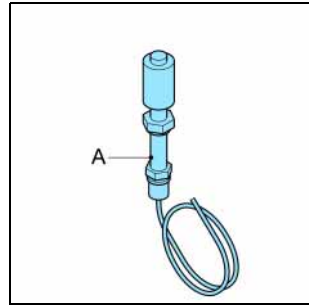

Connection of floaters:

The floater has to be connected to the auxiliary power circuit via the 1 meter (3 foot) long PVC cable (2 x 0.24 mm², 2 x 23 AWG).

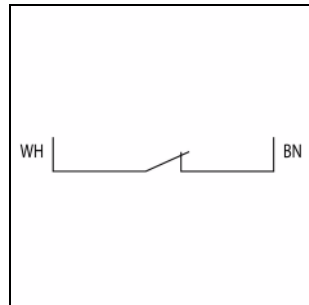

| Specifications | |
|----------------|---------------------------------------|
| Scope: | For use in non-explosive environments |
| Voltage: | Max. 230 V AC/DC |
| Current: | Max. 1 A |
| Power: | Max. 50 VA |



Where the floater is constructed to stop the equipment, operating has to be arranged so that the stop function locks-out, preventing the equipment from being re-started without re-setting. Check if the floater is mounted with the NC sign at the top.

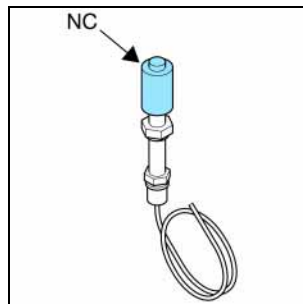

5.4 Lifting and moving the pump

For lifting and moving the *pump head*, it has been fitted with a lifting strip. This lifting strip (A) is fitted on the rear of the pump head. For the weights, refer to § 10.1.6.

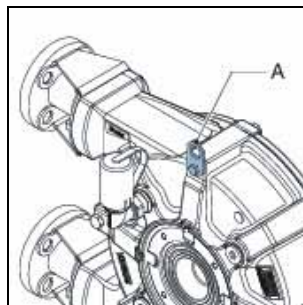

The complete hose pump, i.e. pump head, gearbox and electric motor, must be lifted using the lifting strip of the pump head plus additional support using suitably rated straps or slings (A). For the weights, refer to § 10.1.6.

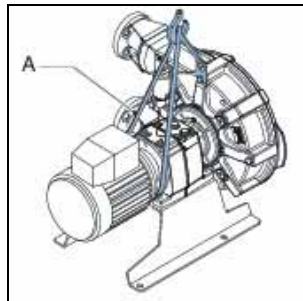

WARNING

If the pump is to be lifted ensure that all standard lifting practices are adhered to and carried out by qualified personnel only.

5.5 Placing the pump

Position the pump on a horizontal surface. Use suitable anchor bolts to attach the pump to the floor surface.

6 COMMISSIONING

6.1 Preparations

**WARNING**

A Bredel VFD that is fitted *without the control switch* starts automatically when power is applied.

**WARNING**

Disconnect and lock the power supply to the pump drive before any work is carried out.
In case the motor is fitted with a frequency controller and has a single-phase power supply, wait two minutes to make sure that the capacitors have discharged.

1. Connect the electric motor and, if present, the frequency controller in conformance with the locally applicable rules and regulations. Refer to § 5.3.4. Have the electrical installation work be carried out by qualified personnel.
2. Check that the lubricant level is above the minimum level line in the inspection window. If necessary refill Bredel Genuine Hose Lubricant via the breather/vent plug. See also § 7.5.
3. Check the rotation of the rotor. The rotational direction of the rotor must match the configuration of suction and discharge piping.
4. Check that the correct number of shims corresponds with your application. Refer to § 10.1.8.
For adjusting the compression force of the hose, refer to § 7.9.

6.2 Commissioning

1. Connect the pipework.
2. Make sure that there are no obstructions such as closed valves.
3. Switch on the hose pump.
4. Check the rotation of the rotor.
5. Check the capacity of the hose pump. If the capacity differs from your specification, follow the instructions in chapter 9 or consult your Bredel representative.
6. Check the capacity range of the frequency controller. In case of any deviations consult the documentation of the supplier.
7. Check the hose pump in accordance with points 2 to 4 of the maintenance table from § 7.2.

7 MAINTENANCE

7.1 General

**WARNING**

Disconnect and lock the power supply to the pump drive before any work is carried out.

In case the motor is fitted with a frequency controller and has a single-phase power supply, wait two minutes to make sure that the capacitors have discharged.

**WARNING**

Only use original Bredel parts when maintaining the hose pump. Bredel cannot guarantee correct operation and any consequential damage that occurs from the use of non-original Bredel components.

See also chapters [2](#) and [3](#).

7.2 Maintenance and periodic inspections

The following maintenance scheme shows the maintenance and periodic inspections that need to be carried out on the hose pump to guarantee optimal safety, operation and life of the pump.

| Point | Action | To be carried out | Remark |
|-------|---|--|--|
| 1 | Check the lubricant level. | Before startup of the pump and on a scheduled interval during operation. | Make sure that the lubricant level is above the minimum level line in the inspection window. If necessary refill the lubricant. See also § 7.5. |
| 2 | Check the pump head for any leakage of lubricant around the cover, the flanges and the rear of the pump head. | Before startup of the pump and on a scheduled interval during operation. | See § 9. |
| 3 | Check the gearbox for any leakage. | Before startup of the pump and on a scheduled interval during operation. | In case of leakage consult your Bredel representative. |
| 4 | Check the pump for deviating temperature or strange noises. | On a scheduled interval during operation. | See § 9. |
| 5 | Check the pressing shoes for excessive damage. | When replacing the pump hose. | See § 7.7. |
| 6 | Internal cleaning of the pump hose. | Cleaning of the system or product change. | See § 7.4. |
| 7 | Replace the pump hose. | Preventive, this means after 75% of the hose life of the first hose. | See § 7.7. |
| 8 | Change lubricant. | After every 2 nd hose change or after 5,000 service hours, whichever comes first or after hose rupture. | See § 7.5 |
| 9 | Change oil in the gearbox. | Refer to the lubricant table in § 10.2. | See § 7.6. |
| 10 | Replace the pump seal. | If necessary. | See § 7.8.2. |

| Point | Action | To be carried out | Remark |
|-------|-----------------------------|--|--|
| 11 | Check the wear ring. | When the pump seal is replaced, check the running surface of the wear ring for excessive wear. | For replacement, contact your Bredel representative. |
| 12 | Replace the pressing shoes. | Wear on the running surface. | See § 7.8.1. |
| 13 | Replace the bearings. | If necessary. | See § 7.8.2. |

7.3 Additional maintenance in potentially explosive environments

The following maintenance scheme shows the additional maintenance and periodic inspections that need to be carried out on the hose pump to guarantee optimal safety, operation and life of the pump in a potentially explosive environment.

| Point | Action | To be carried out | Remark |
|-------|-------------------------|--|--------------|
| 1 | Replacing bearings. | After 40,000 hours service or when damage is suspected. | See § 7.8.2. |
| 2 | Cleaning the hose pump. | In potentially explosive (dust) atmospheres, the dust must be removed regularly. | |

7.4 Cleaning the pump hose

Running the pump with clean water can clean the inside of the pump hose. If a cleaning fluid is added to the water, attention must be given to its compatibility with the hose liner material, and also the temperature at which the cleaning procedure will be performed. Sometimes a cleaning sponge can be very helpful. With many products, it is necessary to clean the pump hose immediately once the pump is stopped to avoid sedimentation and/or hardening of the product within the hose that can cause damage upon restart.

7.5 Changing lubricant

1. Place a tray (A) under the drain plug in the cover of the pump. Remove the drain plug (B). Catch the lubricant from the pump housing in the tray.
2. Position the drain plug (A) and tighten it firmly. In order to facilitate the filling with lubricant the breather plug (B) on the front of the pump housing can be removed.
3. The pump housing can be filled with lubricant via the breather/vent (A) on the rear of the pump housing. For this purpose remove the breather cap (B) and position a funnel (C) in the breather. Pour the lubricant in the pump housing via the funnel.

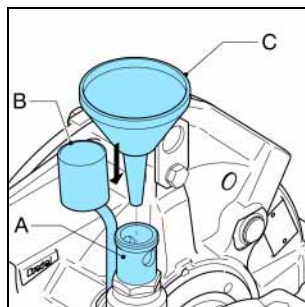
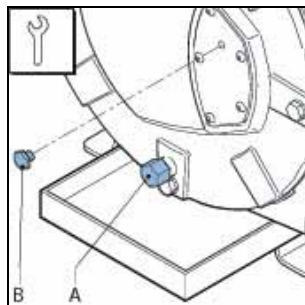
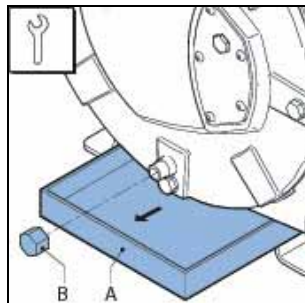

4. Keep on pouring until the lubricant level has risen at least until just above the bottom level line in the inspection window. Position the breather plug (A) and tighten it firmly.

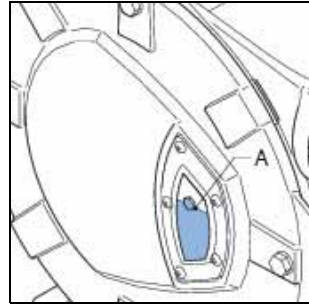

| | |
|---|--|
|  | For the required quantity of lubricant, refer to § 10.1.5. |
|---|--|

7.6 Changing oil in gearbox

1. Isolate the pump from the electrical supply.
2. Remove plug (A) and let the oil run out of the gearbox.
3. The plug (A) is magnetically loaded. In this way metal particles in the oil are pulled to the plug. Clean the plug and remove any metal particles if necessary. Check that the sealing ring is not damaged and replace it if necessary. Place the plug back in the gearbox and tighten it firmly.

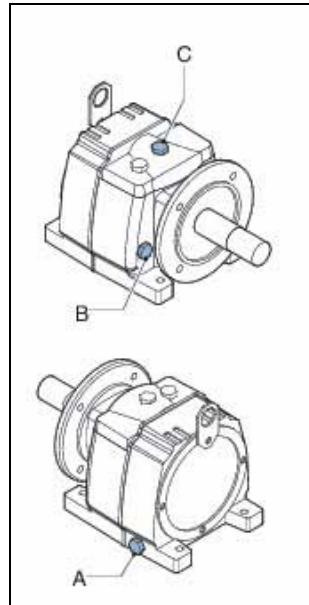

- Remove level plug (B) and filling plug (C) and position a funnel in the hole and fill the gearbox with oil until the oil just comes out of the level plug hole (B). Wait shortly to let out any entrapped air. Place plug (B) and filling plug (C) back and tighten them firmly.



For the required lubricant, refer to § 10.2.



WARNING

To prevent damage to the gears, do not operate the pump unless proper volume of oil is filled into the gearbox.

- Switch on the electrical supply to the pump.

7.7 Replacing pump hose

7.7.1 Removing pump hose

- Isolate the pump from the electrical supply.
- Close any shut-off valves in both the suction and discharge line to minimize product loss.
- Place a tray (A) under the drain plug in the bottom of the pump head. The tray must be large enough to contain the lubricant, possibly contaminated with product fluid, from the pump head. Remove the drain plug (B). Catch the lubricant from the pump housing in the tray. Check that the breather/vent mounted on the rear is not obscured. Position the drain plug and tighten it firmly.

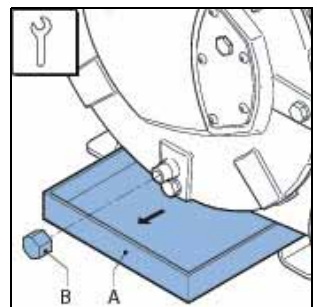

4. Loosen the retaining bolts (A) of both the suction and discharge line (B). Disconnect the suction and discharge lines.

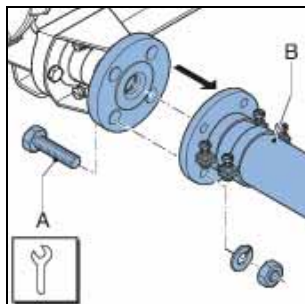

5. Loosen hose clamp (A) of both the inlet and outlet ports by loosening retaining bolt (B).

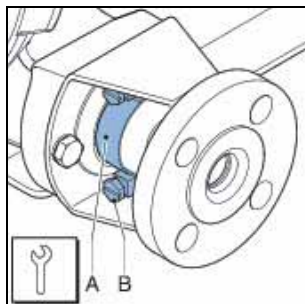

6. Pull the insert (B) from the hose and remove the flanges (A). Carry out this procedure both for the inlet and outlet ports.

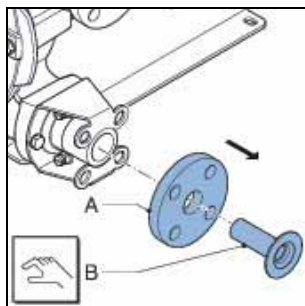

7. Loosen the retaining bolts (A) of the flange bracket (B) and remove the bolts. Slide the flange bracket and the hose clip (C) off the hose. Carry out this procedure both for the inlet and outlet ports.

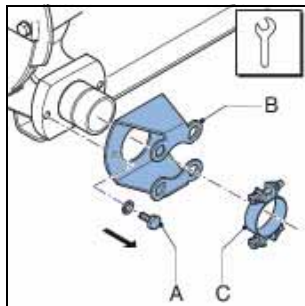

8. Slide off the sealing ring (A). Check that the sealing ring is not deformed or damaged and replace it if necessary. Carry out this procedure both for the inlet and outlet ports.
9. Switch on the electrical supply.
10. Power out the hose (A) from the pump chamber by jogging the drive motor.

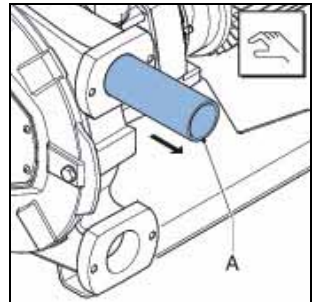
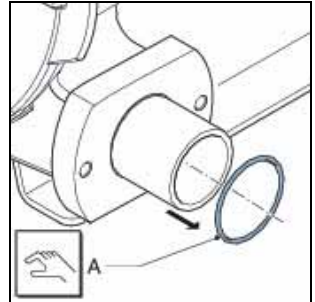
**WARNING**

During jogging the drive:

- Do not stand in front of the pump ports.
- Do not try to guide the hose by hand.

7.7.2 Cleaning the pump head

1. Isolate the pump from the electrical supply.
2. Remove the cover (B) by loosening the retaining bolts (A).
3. Check the sealing ring (C) and replace it if necessary.
4. Rinse the pump head with clean water and remove all residues. Make sure that no rinsing water remains in the pump head.

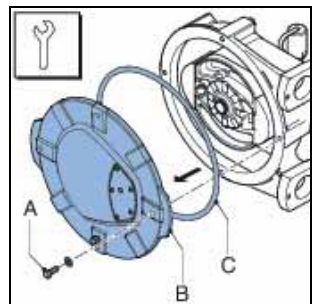

5. Check the pressing shoes for wear or damage and replace them if necessary. Refer to § 7.8.1. Also see the maintenance scheme in § 7.2.

**CAUTION**

When the pressing shoes are worn the compression force of the hose decreases. If the compression force is too low, this results in a loss of capacity by the backflow of the liquid to be pumped. Backflow results in a reduction of the life of the pump hose.

6. Replace the cover and fasten the retaining bolts with the correct torque. Refer to § 10.1.7.
7. Switch on the electrical supply to the pump.

7.7.3 Fitting the pump hose

**WARNING**

Fitting the pump hose is a powered process and requires pump rotation. Ensure the pump cover is properly fitted and that body and tools are clear from moving parts.

**WARNING**

For all weight and torque adjustment, please refer to the technical information section at the rear of this manual.

1. Clean the (new) pump hose on the outside and fully lubricate it with Bredel Genuine Hose Lubricant.
2. Turn on the pump and note the direction of the pump rotation.

- Fit the pump hose (A) via one of the ports – whichever is the suction based on rotation direction. Feed the hose into the port and allow the pressing shoe to draw the hose in the pump housing. The rotor will move the hose.

**WARNING**

During jogging the drive:

- Do not stand in front of the pump ports.
- Do not try to guide the hose by hand.

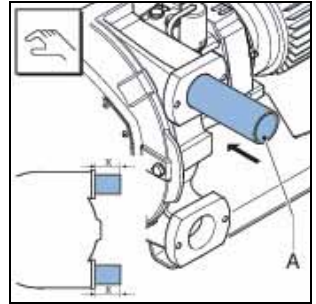

- Stop the motor when the hose sticks out equally from both sides of the pump housing.
- First fit the inlet port. Fit the sealing ring. Before mounting, check that the sealing ring (A) is not deformed or damaged and replace it if necessary.

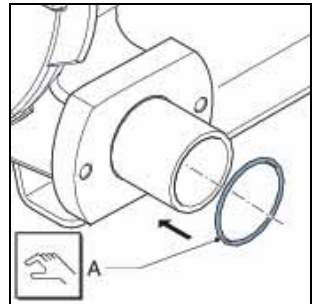

- Before fitting check that the hose clamp is not damaged and replace it if necessary. Slide the flange bracket (B) and the hose clamp (C) over the hose together. Align the holes in the flange bracket with the ones at the front of the port. Position the two retaining bolts (A) and tighten them until they are approx. 5 mm (3/16") from the port, so that the gap between the flange bracket and the port remains.

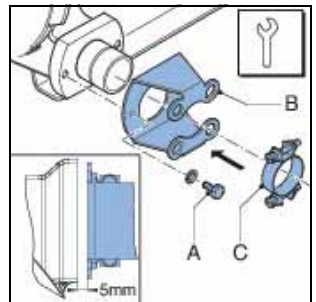

7. Slide insert (B) in flange (A) and press the insert in the hose. If necessary lubricate the insert with Bredel Genuine Hose Lubricant in order to simplify mounting. Make sure that the holes in flange (A) are aligned with the holes in flange bracket (C). Check that the insert is in the correct place. If the insert is not positioned correctly the product to be pumped may leak or the lubricant may leak.

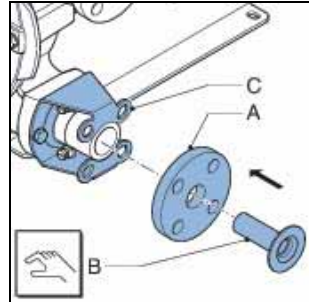

8. Turn the rotor in such a way that the hose (A) is pressed firmly against the flange surface (B).

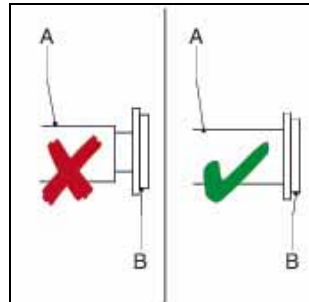

9. Now fully tighten the retaining bolts (A) of the flange bracket (B). Make sure the bolts are tightened with the correct torque. Refer to § 10.1.7.

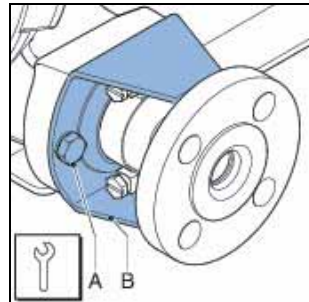

10. Position hose clamp (A) against O-ring chamber of the flange bracket (B) and fasten the retaining bolt. Make sure the bolts are tightened with the correct torque. Refer to § 10.1.7.

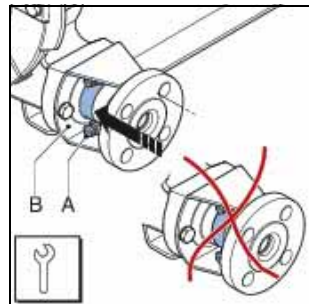

11. Now fit the other port. For this port proceed in the same way as described above for the inlet port.

12. Fill the pump housing with Bredel Genuine Hose Lubricant. Refer to § 7.5.

13. Fit the suction and discharge lines (B) and the retaining bolts (A). Tighten the retaining bolts with the correct torque. Refer to § 10.1.7.

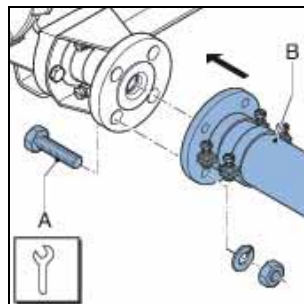

7.8 Exchanging replacement parts

7.8.1 Replacing pressing shoes

1. Jog the motor until the pressing shoe (B) is positioned between the inlet and outlet port (A).
2. Isolate the pump from the electrical supply.

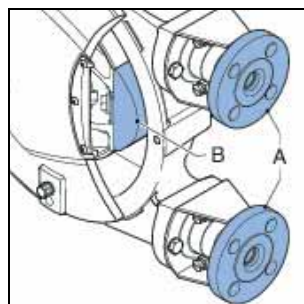

3. Place a tray (A) under the drain plug in the cover of the pump. Remove the drain plug (B). Catch the lubricant from the pump housing in the tray. Position the drain plug and tighten it firmly.

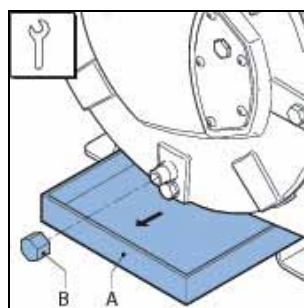

4. Remove the cover (A) by loosening the four retaining bolts (B).

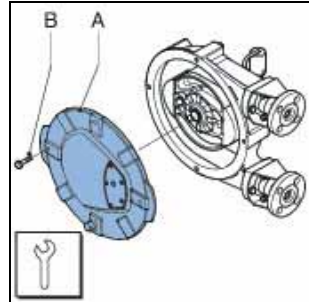

5. Loosen the retaining bolt (A) of the pressing shoe (B). Remove the shims (C) if present.

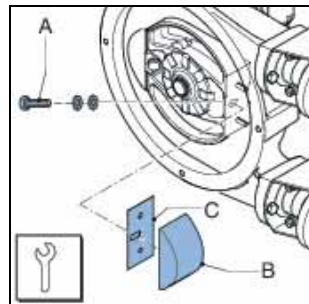

6. Fit the removed shims (C) again. Position the (new) pressing shoe (B), check that the Nord-Lock® rings (D) have been positioned correctly and tighten the retaining bolt(s) (A) a few turns. Refer to § 10.1.7.

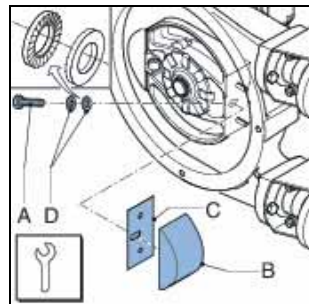

7. Check the gasket (C) for damage and replace if necessary. Refit the cover (B). Make sure that the 4 bolts (A) are refitted and that they are tightened in the correct order, diagonally opposite each other. Refer to § 10.1.7.

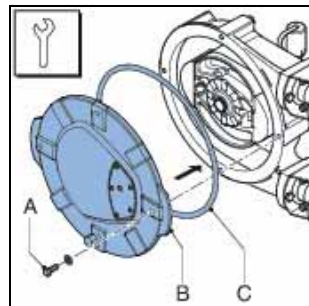

8. Switch on the electrical supply.
9. Jog the motor until the second pressing shoe is positioned between the inlet and outlet port.

10. Isolate the pump from the electrical supply.
11. Repeat the procedure for removing and fitting this second pressing shoe by repeating steps 4 through 8.
12. Refill the lubricant. Refer to § 7.5.

7.8.2 Replacing seal ring and bearings

1. Remove the pump hose. Refer to § 7.7.1.
2. Isolate the pump from the electrical supply.
3. Remove the cover (B) by loosening the retaining bolts (A).
4. Check the sealing ring (C) and replace it if necessary.
5. Loosen the retaining bolt (A) of both pressing shoes (B). Remove the shims (C) if present.

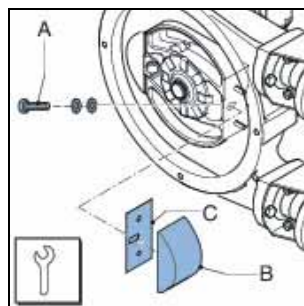
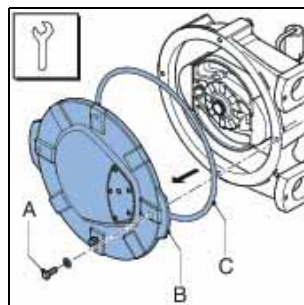

6. Extract the rotor (A) from the hub. Position both crow bars behind the recesses (B) in the rotor.

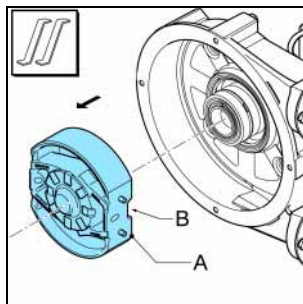

7. Dismount the retaining circlip (A) with the correct tool.

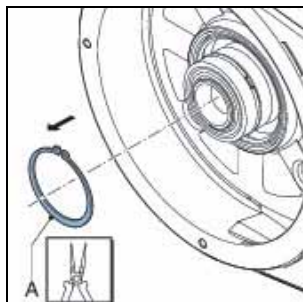

8. Dismount the bearings (A) with the correct tool, the spacer ring (B) and the retaining circlip (C).

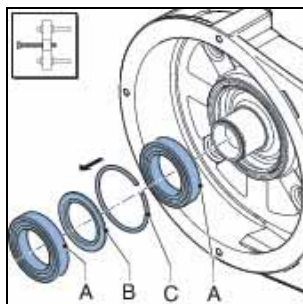

9. Remove the seal (A). Clean and degrease the bore.

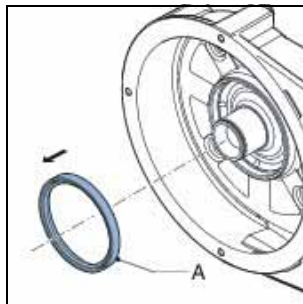

10. Fit a new seal (A) using good engineering practises. The seal must be fitted in the correct orientation (B). Make sure that the open side points to the pump cover.

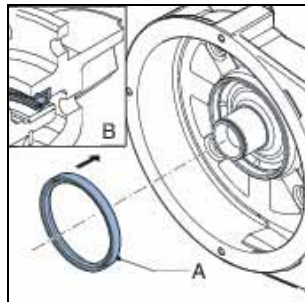

11. Check that the hub is clean and free of grease. Fit the bearings and the rings now. The bearings are placed on the hub with a slight interference fit. Use a pressing tool to press the bearings on the hub.

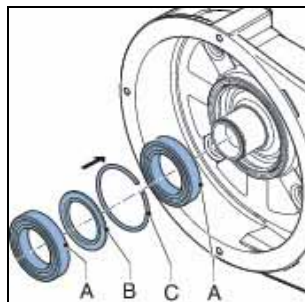

12. Mount the retaining circlip (A).

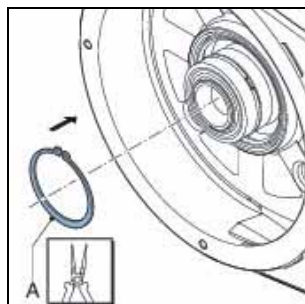

13. Fit rotor (A). The rotor is placed on the bearings with a loose fit. Press the rotor on the hub until it sticks.

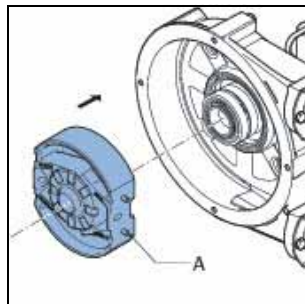

14. Fit the removed shims (C) again. Position the (new) pressing shoe (B), check that the Nord-Lock® rings (D) have been positioned correctly and tighten the retaining bolt(s) (A) a few turns. Refer to § 10.1.7.

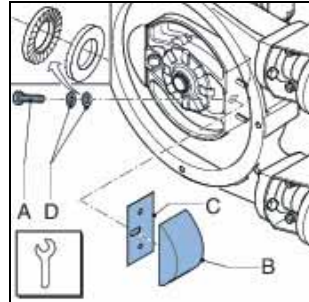

15. Check the gasket (C) for damage and replace if necessary. Refit the cover (B). Make sure that the 4 bolts (A) are refitted and that they are tightened in the correct order, diagonally opposite each other. Refer to § 10.1.7.

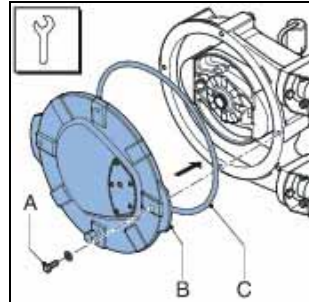

16. Switch on the electrical supply to the pump.
17. Fit the (new) pump hose. Refer to § 7.7.3.

7.9 Adjusting hose compression force (shimming)

Remove the pump cover before fitting and removing shims. In order to determine the correct number of shims for your specific application refer to § 10.1.8.



CAUTION

Too many shims, this means a too high compression force on the pump hose, will create a too high load on the pump head and pump hose, which may result in a reduction of the life of the pump hose and bearings.

**CAUTION**

Too few shims, this means a too low compression force on the pump hose, create a loss of yield and slip or backflow. Backflow results in a reduction of the life of the pump hose.

1. Jog the motor until the pressing shoe (B) is positioned between the inlet and outlet port (A).
2. Isolate the pump from the electrical supply.
3. Place a tray (A) under the drain plug in the cover of the pump. Remove the drain plug (B). Catch the lubricant from the pump housing in the tray. Position the drain plug and tighten it firmly.
4. Remove the cover (B) by loosening the retaining bolts (A).

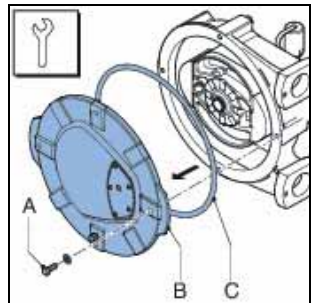
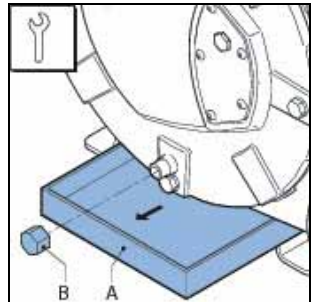
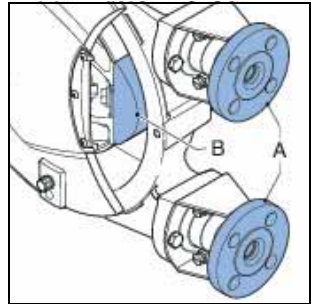

5. Loosen the retaining bolt (A) of the pressing shoe (B). Fit the shims (C) or remove them, until the correct number of shims is present. Refer to § 10.1.8.
Fasten the retaining bolt of the pressing shoe with the correct torque. Refer to § 10.1.7.

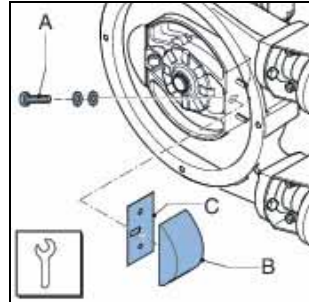

6. Refit the cover (B). Check the gasket (C) for damage and replace if necessary. Make sure that all bolts (A) are refitted and that they are tightened in the correct order, diagonally opposite each other. Refer to § 10.1.7.

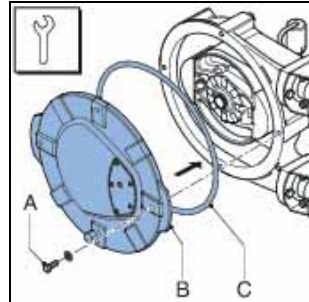

7. Switch on the electrical supply.
8. Jog the rotor until the second pressing shoe is positioned between the inlet and outlet port.
9. Isolate the pump from the electrical supply.
10. Repeat the procedure for this pressing shoe by repeating steps 4, 5, 6 and 7.
11. Refill the lubricant via the breather. Refer to § 7.5.

7.10 Options

7.10.1 Revolution counter

For feedback of the pump revolutions to an "intelligent" system, the pump can be provided with an inductive sensor (A). This sensor is mounted at the backside of the pump.

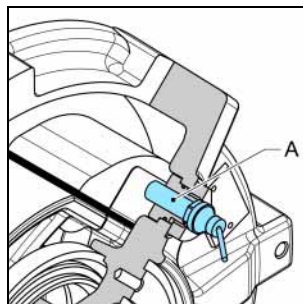

Connection of the revolution counter:

The speed sensor can be connected via the 2 meter (6.5 foot) long PVC cable (3 x 0.34 mm², 3 x 22 AWG).

| Specifications | |
|----------------|---------------------------------------|
| Scope: | For use in non-explosive environments |
| Voltage: | 10...30 VDC |
| Current: | Max. 200 mA |

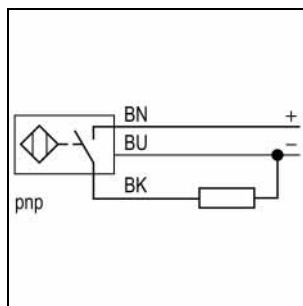

Adjustment sensor:

The sensor (A) must be adjusted at an offset of 1-2 mm (0.04-0.08 inch) to the special shim (B).

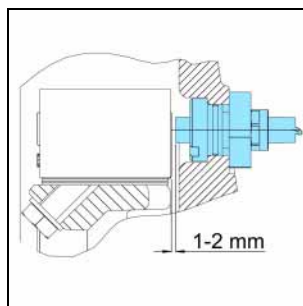

7.10.2 Drain connection

Drain piping can be connected with an optional part (A) fitted at the breather. This is a 1" NPT threaded connection.

**CAUTION**

The drain piping must be connected to an open reservoir, to prevent pressure built up inside the pump housing.

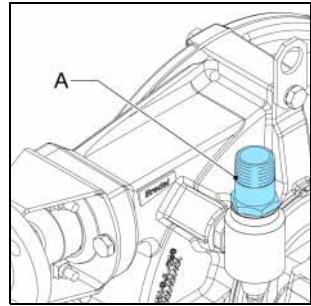

8 STORAGE

8.1 Hose pump

- Store the hose pump or pump parts in a dry area. Make sure that the hose pump or pump parts are not exposed to temperatures lower than -40 °F or higher than +140 °F.
- Cover the openings of the inlet and outlet ports.
- Prevent corrosion of untreated parts. For this purpose use the correct protection or packaging means.
- After a long period of standstill or storage, the static load on the pump hose may have caused permanent deformation, which will reduce the life of the pump hose. To prevent this, remove a pressing shoe. Jog the rotor until the second pressing shoe is positioned between the inlet and outlet port. In this way there is no load put on the pump hose.

8.2 Pump hose

- Store the pump hose in a cool and dark room. After two years the hose material will age, which will reduce the life of the hose.

9 TROUBLESHOOTING



WARNING

Disconnect and lock the power supply to the pump drive before any work is carried out.

In case the motor is fitted with a frequency controller and has a single-phase power supply, wait two minutes to make sure that the capacitors have discharged.

If the hose pump does not function (correctly), consult the following checklist to see if you can remedy the error yourself. If this is not the case, contact your Bredel representative.

| Problem | Possible cause | Correction |
|----------------------------|---|---|
| Failure to operate. | No voltage. | Check that the supply power switch is on. |
| | | Check the electrical supply is available at the pump. |
| | Stalled rotor. | Check if the pump is stalled by incorrect fitting of the hose. |
| | Lubricant level monitoring system has been activated. | Check that the lubricant level monitoring system has stalled the pump. Check the functioning of the lubricant level monitoring system, or check the lubricant level. |

| Problem | Possible cause | Correction |
|-------------------------------|--|--|
| High pump temperature. | Non standard hose lubricant used. | Consult your Bredel representative for the correct lubricant. |
| | Low lubricant level. | Add Bredel Genuine Hose Lubricant. For the required amount of lubricant refer to § 10.1.5. |
| | Product temperature too high. | Consult your Bredel representative about the maximum temperature range of the product. |
| | Internal friction on the hose caused by blocked or poor suction characteristics. | Check pipework/valves for blockages. Ensure that the suction pipework is as short as possible and that the diameter is large enough. |
| | Over-shimming of the pump rotor shoes. | Consult the diagram. Refer to § 10.1.8. Remove excess shims. |
| | High pump speed. | Reduce pump speed to a minimum. Consult with your Bredel pump representative for advice on optimum pump speeds. |

| Problem | Possible cause | Correction |
|---------------------------------|---|--|
| Low capacity / pressure. | Shut-off valve in the suction line (partly) closed. | Fully open the shut-off valve. |
| | Under shimming of the pressing shoes. | Consult the diagram in § 10.1.8. Fit the correct number of shims. |
| | Hose rupture or badly worn hose. | Replace hose. Refer to § 7.7. |
| | (Partial) blockage of the suction line or too little product on the suction side. | Ensure that the suction line is clear of blockages and that sufficient product is available. |
| | Connections and hose clamps not correctly mounted, which makes the pump suck air. | Tighten connections and hose clamps. |
| | The filling degree of the pump hose is too low, because the speed is too high in relation to the viscosity of the product to be pumped and the inlet pressure. The suction line can be too long or too narrow or a combination of these factors. | Consult your Bredel representative for a recommendation. |

| Problem | Possible cause | Correction |
|--|---|---|
| Vibration of the pump and pipework. | Suction and discharge lines are not secured correctly. | Check and secure pipe-work. |
| | High pump speed with long suction and discharge lines or high relative density or a combination of these factors. | Reduce pump speed. Reduce the line lengths on both suction and discharge where possible. Consult your Bredel representative for a recommendation. |
| | Too narrow diameter of suction and/or discharge line. | Increase the diameter of the suction/discharge lines. |
| Short hose life. | Chemical attack of the hose. | Check the compatibility of the hose material with the product to be pumped. Consult your Bredel representative for correct hose selection. |
| | High pump speed. | Reduce pump speed. |
| | High discharge pressures. | Maximum working pressure 1600 kPa (232 psi). Check that the discharge line is not blocked, the shut-off valves are fully opened and the pressure relief valve functions properly (if present in the discharge line). |
| | High product temperature. | Consult your Bredel representative for correct hose selection. |
| | High pulsations. | Restructure the discharge and inlet conditions. |

| Problem | Possible cause | Correction |
|---|---|--|
| Hose pulled into the pump. | Insufficient or no hose lubricant in the pump head. | Add extra lubricant. Refer to § 7.5. |
| | Incorrect lubricant: no Bredel Genuine Hose Lubricant in the pump head. | Consult the Bredel representative for the correct lubricant. |
| | Extremely high inlet pressure - larger than 300 kPa (43.5 psi). | Reduce the inlet pressure. |
| Lubricant leakage at flange bracket. | Hose blocked by an incompressible object in the hose. The hose cannot be compressed and will be pulled into the pump housing. | Remove hose, check for blockages and replace if necessary. |
| | Bolts of flange bracket loose. | Tighten to the specified torque settings. Refer to § 10.1.7. |
| | Bolts of hose clamps loose. | Tighten to the specified torque settings. Refer to § 10.1.7. |
| Leakage from the rear of the pump housing "Buffer zone". | Damaged sealing ring. | Replace sealing ring. |
| Motor functions, but rotor does not. | Broken fracture surface on rotor. | Replace the rotor. |
| Extreme corrosion inside the pump. | When the pump temperature goes above 140 °F, the corrosion speed can rise excessively, depending on the product. | Lower the pump temperature, by using the pump intermittently. Or mount a temperature switch, to prevent the pump temperature from rising above 140 °F. |

10 SPECIFICATIONS
10.1 Pump head
10.1.1 Performance

| Description | Unit | DuCoNite® 25 | DuCoNite® 32 |
|-----------------------------------|-------------------|--------------|--------------|
| Max. capacity, continuous | m ³ /h | 1.80 | 3.25 |
| | gpm | 7.92 | 14.31 |
| Max. capacity, intermittent* | m ³ /h | 2.88 | 5.25 |
| | gpm | 12.68 | 23.12 |
| Capacity per revolution | l/rev | 0.300 | 0.625 |
| | gal/rev | 0.079 | 0.165 |
| Max. permissible working pressure | kPa | 1600 | |
| | psi | 232 | |
| Permissible ambient temperature | °C | -20 to +45 | |
| | °F | -4 to +113 | |
| Permissible product temperature | °C | -10 to +60 | |
| | °F | +14 to +140 | |
| Sound level at 1 m (3.3 ft) | dB(A) | 70 | |

* Intermittent duty: "Let the pump stand still to cool down for at least 1 hour after 2 hours of operation".

10.1.2 Materials

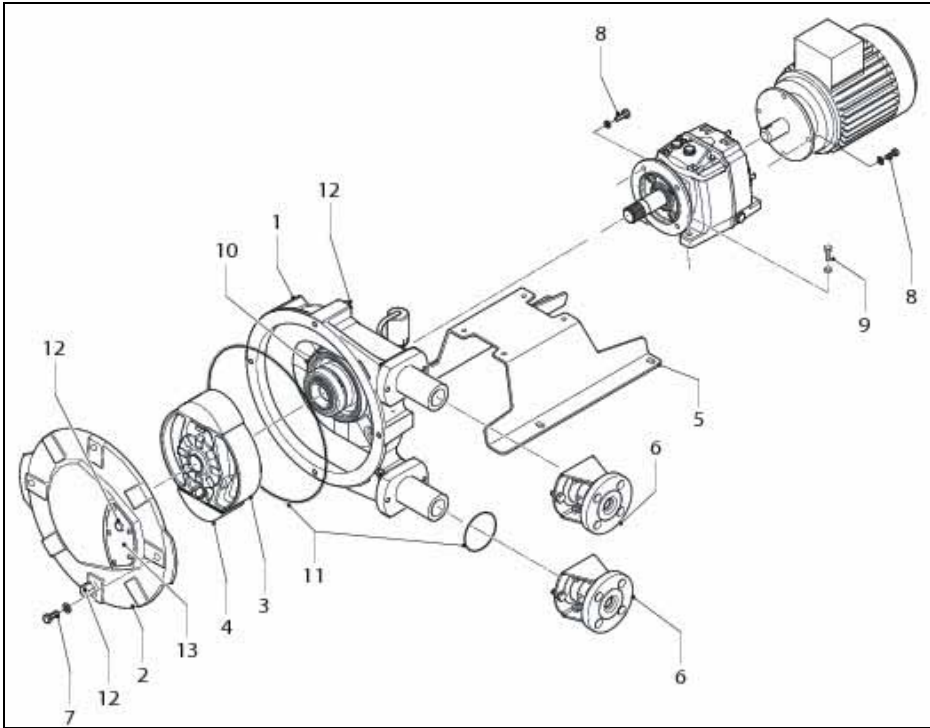

| Pos | Description | Material |
|-----|-----------------------------------|---|
| 1 | Pump housing | Cast-iron with DuCoNite [®] coating |
| 2 | Cover | Cast-iron with DuCoNite [®] coating |
| 3 | Pump rotor | Cast-iron with DuCoNite [®] coating |
| 4 | Pressing shoe | Epoxy |
| 5 | Pump support | AISI 316 |
| 6 | Flange bracket | AISI 316 |
| 7 | Mounting material of pump cover | AISI 316 |
| 8 | Mounting material of drive system | AISI 316 |
| 9 | Mounting material of pump support | AISI 316 |
| 10 | Seal | VITON |
| 11 | Seals, gaskets | EPDM |
| 12 | Fitting | PVC |
| 13 | Inspection cover | PVC |

10.1.3 Surface treatment

Pump head

The main pump head parts (pump housing, cover and rotor) are provided with a special **DuCoNite®** coating, which is both chemical and wear resistant. For the chemical resistance chart refer to § 10.1.4.

Gearbox-electric motor

After surface preparation, one layer of 2-component acrylate is used for surface protection. The standard color is RAL 9005. Contact your Bredel representative for details on surface treatment.

10.1.4 Chemical resistance chart DuCoNite® coating

| Chemical | Concentration | Chemical compatibility with DuCoNite® | Hose material |
|------------------------------------|---------------|---------------------------------------|---------------|
| Sodium Hypochlorite | up to 18% | good | EPDM |
| Sodium Bisulphate | 38% | good | EPDM |
| Ferric Chloride | up to 50% | good | EPDM |
| Ferrous Chloride | 35% | good | EPDM |
| Alum | 50% | good | EPDM |
| Polymer | | good | EPDM |
| Fluoride (Hydrofluorosilicic Acid) | 18-24% | limited | EPDM |
| Sodium Hydroxide | 20-50% | good | EPDM |
| Potassium Permanganate | 50% | good | EPDM |
| Potassium Hydroxide | up to 70% | good | EPDM |
| Aqueous Ammonia | 20% | limited | EPDM |
| Methanol | | good | EPDM |
| Sulfuric Acid | 93-97% | good | CSM |
| Peroxide | 50% | good | CSM |
| Citric Acid | 50% | good | EPDM |
| Zinc Orthophosphate | 25% | good | EPDM |

| Chemical | Concentration | Chemical compatibility with DuCoNite® | Hose material |
|-----------------|---------------|---------------------------------------|---------------|
| Phosphoric Acid | 50% | good | EPDM |
| Nitric Acid | 25% | limited | CSM |

If the ambient temperature is above 104 °F consult your Bredel representative.

10.1.5 Lubricant table pump

| | Unit | DuCoNite® 25 | DuCoNite® 32 |
|-------------------|------|-------------------------------|-------------------------------|
| Lubricant | - | Bredel Genuine Hose Lubricant | Bredel Genuine Hose Lubricant |
| Required quantity | l | 2.5 | 4.5 |
| | gal | 0.7 | 1.2 |

Bredel Genuine Hose Lubricant is registered at NSF: NSF Registration N° 123204; Category Code H1. See also: www.NSF.org/USDA.

| | |
|---|--|
|  | Should you require additional information with respect to the safety data sheet, consult your Bredel representative. |
|---|--|

10.1.6 Weights

| Description | Unit | Weight | |
|-------------------------|------|--------------|--------------|
| | | DuCoNite® 25 | DuCoNite® 32 |
| Main components: | | | |
| Pump head | kg | 55 | 82 |
| | lbs | 121 | 180.4 |
| Gearbox | kg | 14.5 | 20 |
| | lbs | 31.9 | 44 |

| Description | Unit | Weight | |
|------------------------|------|----------------------|--------------------|
| | | DuCoNite® 25 | DuCoNite® 32 |
| Motor | kg | 11 - 17 | 11 - 23 |
| | lbs | 24.2 - 37.4 | 24.2 - 50.6 |
| Total unit: | kg | 81 - 87 | 113 - 125 |
| | lbs | 178.2 - 191.4 | 248.6 - 275 |
| Components: | | | |
| Hose | kg | 2 | 3 |
| | lbs | 4.4 | 6.6 |
| Lubricant | kg | 3 | 5.5 |
| | lbs | 6.6 | 12.1 |
| Gearbox G0311... | kg | 14.5 | |
| | lbs | 31.9 | |
| Gearbox G0321... | kg | 14.5 | |
| | lbs | 31.9 | |
| Gearbox G0361... | kg | | 20 |
| | lbs | | 44 |
| Gearbox G0371... | kg | | 20 |
| | lbs | | 44 |
| Motor 0.55 kW, E013201 | kg | 11 | |
| | lbs | 24.2 | |
| Motor 0.75 kW, E015211 | kg | 11 | |
| | lbs | 24.2 | |
| Motor 1.1 kW, E015221 | kg | 15 | |
| | lbs | 33 | |
| Motor 1.5 kW, E015231 | kg | 17 | |
| | lbs | 37.4 | |
| Motor 2.2 kW, E015241 | kg | 23 | |
| | lbs | 50.6 | |

10.1.7 Torque figures

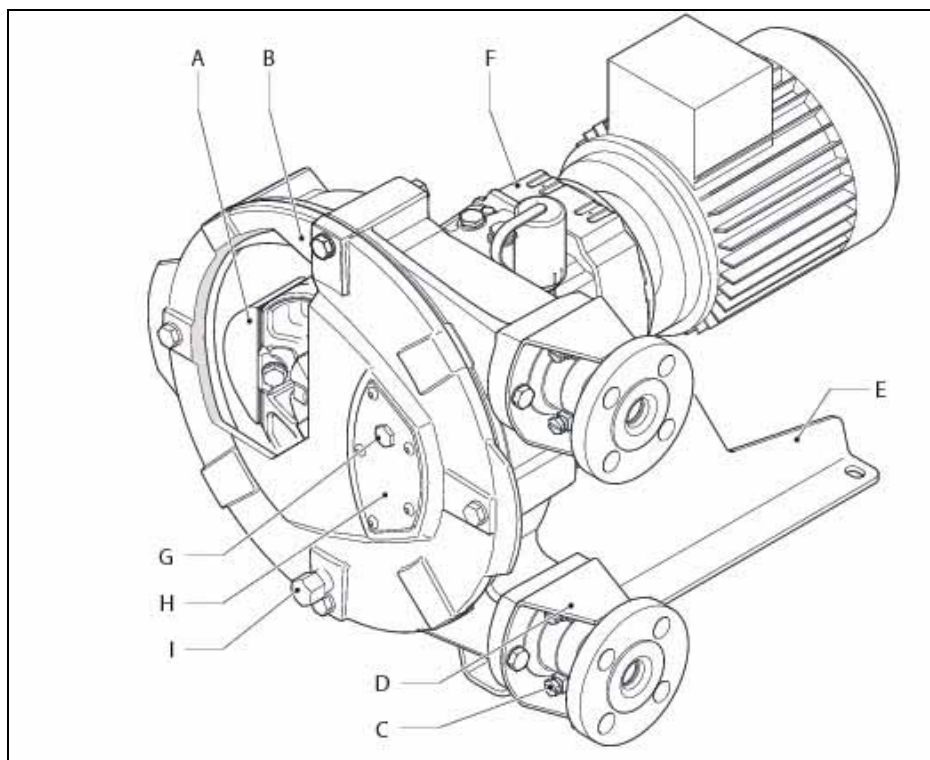

| Pos | Description | Unit | Torques | |
|-----|----------------|--------|--------------|--------------|
| | | | DuCoNite® 25 | DuCoNite® 32 |
| A | Pressing shoe | Nm | 50 | 50 |
| | | lbf in | 440 | 440 |
| B | Cover | Nm | 50 | 50 |
| | | lbf in | 442.5 | 442.5 |
| C | Hose clamp | Nm | 40 | 40 |
| | | lbf in | 354 | 354 |
| D | Flange bracket | Nm | 50 | 50 |
| | | lbf in | 442.5 | 442.5 |
| E | Support | Nm | 25 | 85 |
| | | lbf in | 221.2 | 752.2 |

| Pos | Description | Unit | Torques | |
|-----|-------------------|--------|--------------|--------------|
| | | | DuCoNite® 25 | DuCoNite® 32 |
| F | Gearbox | Nm | 25 | 50 |
| | | lbf in | 221.2 | 442.5 |
| G | Breather plug | Nm | 3 | 3 |
| | | lbf in | 26.5 | 26.5 |
| H | Inspection Window | Nm | 1.5 | 1.5 |
| | | lbf in | 13.2 | 13.2 |
| I | Drain plug | Nm | 3 | 3 |
| | | lbf in | 26.5 | 26.5 |

10.1.8 Shims specifications

- When the product temperatures are above 140 °F always use one shim less than indicated in the diagrams.
- Always round up the number of shims.

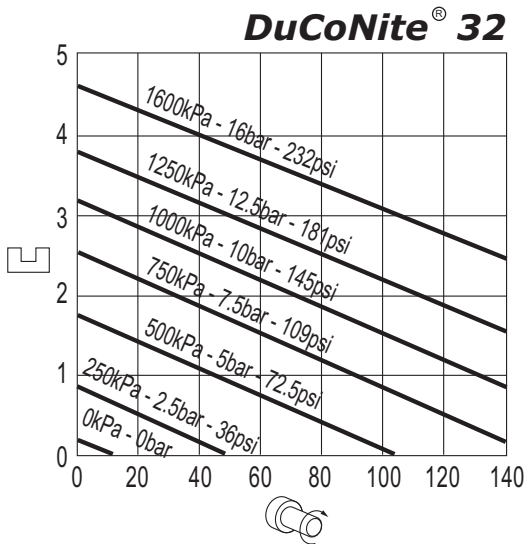
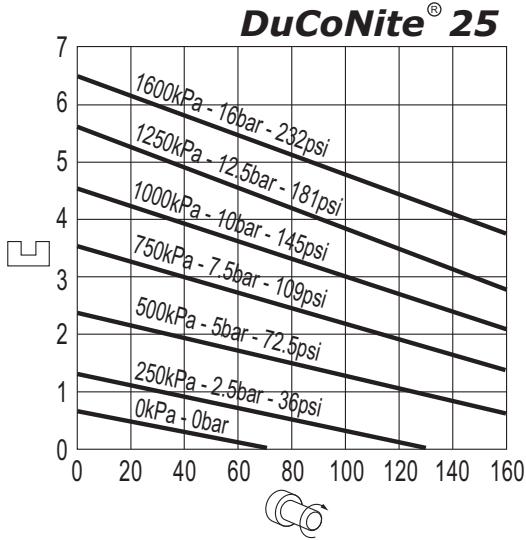

10.2 Lubricant table gearbox

Below is an overview of some of the recommended lubricants for the *co-axial gearbox*. In the majority of the cases, a mineral oil ISO VG 220 is recommended. In case of extreme ambient temperatures or a relatively wide range of ambient temperatures, a synthetic oil is recommended. Contact your Bredel representative for advice.

| Recommended lubricants for the Bredel co-axial gearboxes | | | |
|--|----------------------|-------------------------|----------------------|
| Oil type | Mineral oil | Synthetic oil | |
| Change oil every | 5000 hours | 20,000 hours | |
| Ambient temperature | -10 °C to +40 °C | -40 °C to +80 °C | -30 °C to +60 °C |
| | 14 °F to 104 °F | -40 °F to 176 °F | -22 °F to 140 °F |
| DIN (ISO) | CLP (CC) | CLP HC | CLP HC |
| ISO, NLGI | VG220 | VG220 | VG150 |
| Mobil | Mobilgear 630 | Mobil SHC 630 | Mobil SHC 629 |
| Shell | Shell Omala 220 | Shell Omala 220 HD | |
| Klüber | Klüberoil GEM 1-220 | Klübersynth GH4-220 | Klübersynth EG 4-150 |
| Aral | Aral Degol BG 220 | Aral Degol PAS220 | |
| BP | BP Energol GR-XP 220 | | |
| Tribol | Tribol 1100/220 | Tribol 1510/220 | |
| Texaco | Meropa 220 | Pinnacle EP220 | Pinnacle EP150 |
| Optimol | Optigear BM 220 | Optigear Synthetic A220 | |
| Fuchs | Renolin CLP 220 | Renolin Unisyn CLP220 | |

| Recommended lubricants for the Bredel co-axial gearboxes | | | |
|--|--------------------------|----------------------------|--------------------|
| Oil type | Synthetic oil | | |
| Change oil every | 20,000 hours | | |
| Ambient temperature | -30 °C to -10 °C | -30 °C to +60 °C | -30 °C to +40 °C |
| | -22 °F to 14 °F | -22 °F to 140 °F | -22 °F to 104 °F |
| DIN (ISO) | CLP HC | HCE | E |
| ISO, NLGI | VG32 | VG460 | VG460 |
| | | Foodgrade* | Biology** |
| Mobil | Mobil SHC 624 | | |
| Shell | | Shell Cassida Fluid GL 460 | |
| Klüber | Klüber-Summit HySyn FG32 | Klüber oil 4UH1-460 | Klüberbio CA2-460 |
| Aral | | Aral Eural Gear 460 | Aral Degol BAB 460 |
| Texaco | Cetus PAO 46 | | |
| Optimol | | Optileb GT 460 | Optisynt BS460 |

* For use in the foodstuffs industry. Meets the requirements of the USDA (United States Department of Agriculture); lubricant is suited for unforeseen contact with foodstuffs.

** Lubricant for use in agricultural areas and nature reserves.

10.3 Gearbox

Co-axial gearbox with helical gears. Standard as a 2 and 3 stage version.

| | |
|------------------------|--|
| Mounting position | IM 2001 (IM B35) foot flange gearbox with splined shaft in horizontal position. |
| Motor adapter | Electric motor has been integrated in the gearbox housing, by which the smallest possible dimension is achieved. |
| Optional motor adapter | Adapters in conformance with IEC-B5 or NEMA TC. |

10.4 Electric motor

Standard electric motor design is an enclosed three-phase asynchronous motor. A thermal safety device to prevent motor overload is optional.



In case of doubt about the local applicable regulations for the drive connection, contact your Bredel representative.

| | |
|-------------------------|---|
| Protection class | IP55/IK08 |
| Insulation class | F |
| Increase in temperature | Within class B |
| Voltage/frequency | 230/400 V - 3 phases - 50 Hz or 230/460 V - 3 phases - 60 Hz |

10.5 Frequency controller

The frequency controller has been preprogrammed and only needs to be connected to the mains.

| | |
|--------------------|---|
| RFI filter | Integrated RFI filter B (industrial applications). |
| Control | Rotary knob for setting the speed and the keys for starting forward, stop and starting reverse. |
| Protection class | IP65 |
| Mains power supply | There are 3 types available; the choice depends on the local electricity grid: <ul style="list-style-type: none"> • 200-240 V \pm 10%; 50/60 Hz \pm 5%; 1 ph • 200-240 V \pm 10%; 50/60 Hz \pm 5%; 3 ph • 400-480 V \pm 10%; 50/60 Hz \pm 5%; 3 ph |

10.6 Parts list

10.6.1 Overview

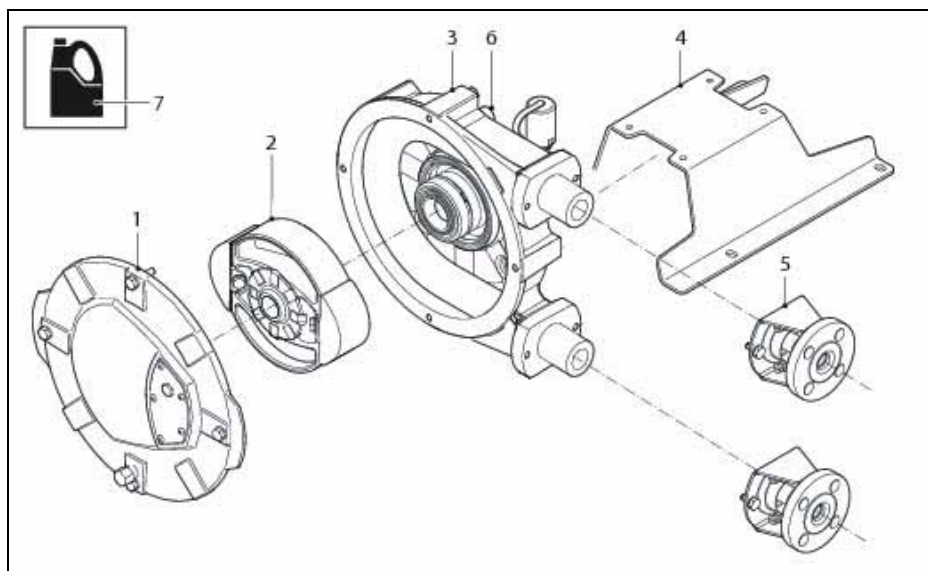

| Pos. | Description |
|------|---|
| 1 | Cover assembly. Refer to § 10.6.2. |
| 2 | Rotor assembly. Refer to § 10.6.3. |
| 3 | Pump housing assembly. Refer to § 10.6.4. |
| 4 | Pump support assembly. Refer to § 10.6.5. |
| 5 | Flange assembly. Refer to § 10.6.6. |
| 6 | Revolution counter assembly. Refer to § 10.6.7. |
| 7 | Lubricant. Refer to § 10.6.8. |

10.6.2 Cover assembly

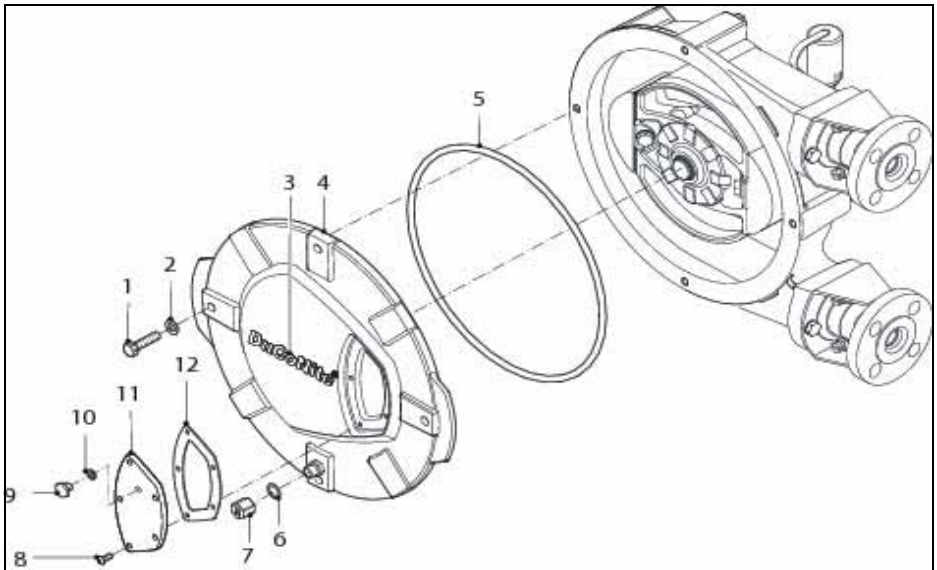

| Pos. | Qty. | Description | Product codes for parts of pump type | |
|------|------|--------------------------|--------------------------------------|--------------|
| | | | DuCoNite® 25 | DuCoNite® 32 |
| 1 | 4 | Bolt, hex. head, M10X40 | F502045 | F502045 |
| 2 | 4 | Washer, M10 | F523013 | F523013 |
| 3 | 1 | DuCoNite® sticker | 225239 | 232239 |
| 4 | 1 | Cover DuCoNite® | 225102N | 232102N |
| 5 | 1 | Quad ring | 225123 | 232123 |
| 6 | 1 | Gasket | 29017349 | 29017349 |
| 7 | 1 | Drain plug | 29025348 | 29025348 |
| 8 | 5 | Round head screw, M6X16 | F552536 | - |
| | 6 | | - | F552536 |
| 9 | 1 | Breather plug | 29017463 | 29017463 |
| 10 | 1 | O-ring | S120113 | S120113 |
| 11 | 1 | Inspection window | 225155N | 232155N |
| 12 | 1 | Gasket | 225156 | 232156 |

10.6.3 Rotor assembly

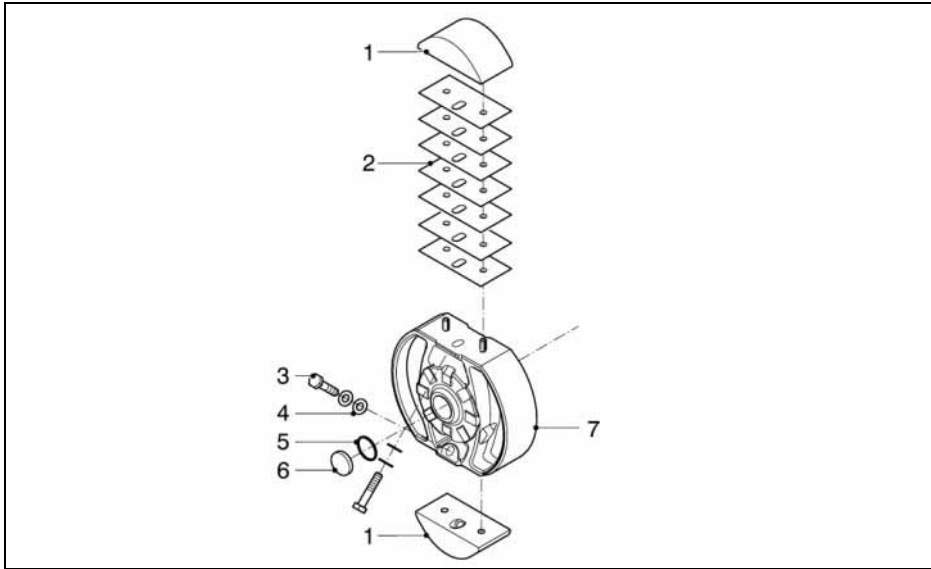

| Pos. | Qty. | Description | Product codes for parts of pump type | |
|------|------|-------------------------------------|--------------------------------------|--------------|
| | | | DuCoNite® 25 | DuCoNite® 32 |
| 1 | 2 | Pressing shoe | 225109 | 232109 |
| | | Pressing shoe with titanium inserts | 225109N | 232109N |
| 2 | 14 | Shim | 225107 | - |
| | 10 | | - | 232107 |
| | 14 | Shim, titanium | 225107N | - |
| | 10 | | - | 232107N |
| 3 | 2 | Bolt, hex. head, M10X50 | F502047 | F502047 |
| | | Bolt, hex. head, M10X50 titanium | F504080-1 | F504080-1 |
| 4 | 2 | Nord-Lock ring, M10 | F349506 | F349506 |
| | | Washer, M10 titanium | F523013-1 | F523013-1 |
| 5 | 1 | O-ring | S120263 | S120263 |
| 6 | 1 | Sealing cap | 29035456 | 29035456 |
| 7 | 1 | Rotor DuCoNite® | 225103N | 232103N |

10.6.4 Pump housing assembly

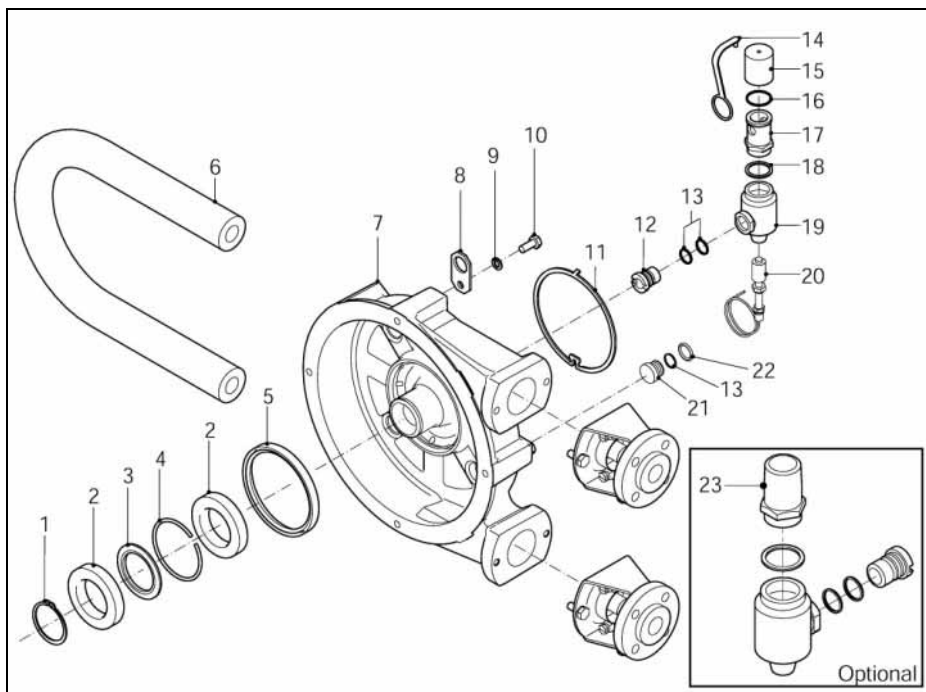

| Pos. | Qty. | Description | Product codes for parts of pump type | |
|------|------|-------------------------------|--------------------------------------|--------------|
| | | | DuCoNite® 25 | DuCoNite® 32 |
| 1 | 1 | Circlip, A60 | F343049 | F343049 |
| 2 | 2 | Bearing | B141260 | B141260 |
| 3 | 1 | Spacer ring | 29085201 | 29085201 |
| 4 | 1 | Retaining circlip | 29095297 | 29095297 |
| 5 | 1 | Seal | S312415 | S312415 |
| 6 | 1 | NR | 025020 | 032020 |
| | 1 | NBR | 025040 | 032040 |
| | 1 | CSM | 025070 | 032070 |
| | 1 | EPDM | 025075 | 032075 |
| 7 | 1 | Pump housing DuCoNite® | 225101N | 232101N |
| 8 | 1 | Lifting strip | 29065361 | 29065361 |
| 9 | 1 | Bolt, hex. head, M10X25 | F504075 | F504075 |

| Pos. | Qty. | Description | Product codes for parts of pump type | |
|------|------|--------------------------|--------------------------------------|--------------|
| | | | DuCoNite® 25 | DuCoNite® 32 |
| 10 | 1 | Washer, Spring Lock, M10 | F532010 | F532010 |
| 11 | 1 | Seal | 225114 | 232114 |
| 12 | 1 | Breather connection plug | 29034451 | 29034451 |
| 13 | 5 | O-ring | S120183 | S120183 |
| 14 | 1 | Breather strip | 29210222 | 29210222 |
| 15 | 1 | Breather cap | 29045221 | 29045221 |
| 16 | 1 | O-ring | S120263 | S120263 |
| 17 | 1 | Breather pipe | 29060453 | 29060453 |
| 18 | 1 | Gasket | 29038352 | 29038352 |
| 19 | 1 | Breather housing | 29086450 | 29086450 |
| 20 | 1 | High level switch | 900610 | 900610 |
| 21 | 3 | Plug | 29029455 | 29029455 |
| 22 | 3 | O-ring | S122113 | S122113 |
| 23 | 1 | Drain pipe | 29060454 | 29060454 |

10.6.5 Support assembly

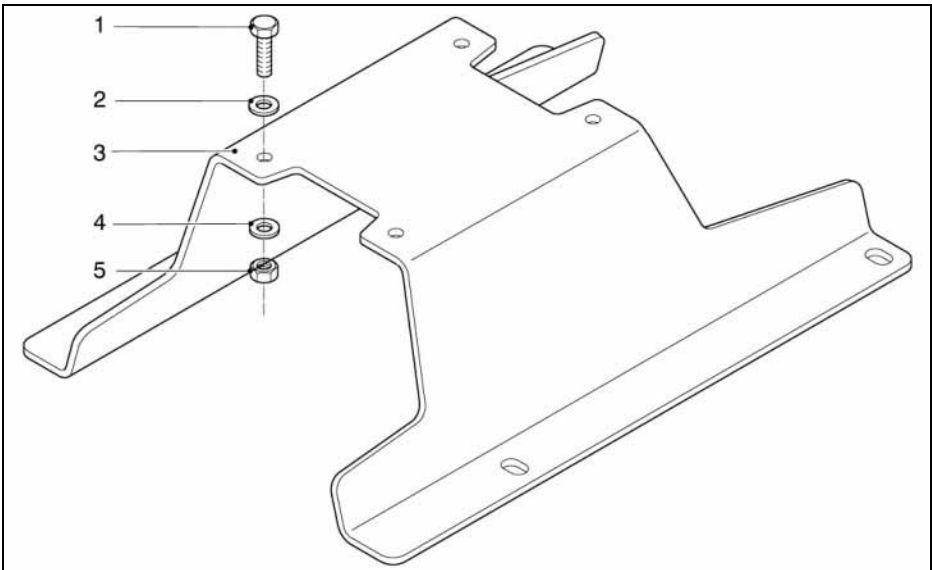

| Pos. | Qty. | Description | Product codes for parts of pump type | |
|------|------|--------------------------|--------------------------------------|--------------|
| | | | DuCoNite® 25 | DuCoNite® 32 |
| 1 | 4 | Bolt, hex. head, M8X35 | F504057 | - |
| | | Bolt, hex. head, M12x45 | - | F502067 |
| 2 | 4 | Washer, M8 | F523012 | - |
| | | Washer, M12 | - | F523014 |
| 3 | 1 | Pump support (standard) | 225106A | 232106A |
| 4 | 4 | Washer, Spring Lock, M8 | F532009 | - |
| | | Washer, Spring Lock, M12 | - | F532011 |
| 5 | 4 | Nut, M8 | F516012 | - |
| | | Nut, M12 | - | F516014 |

10.6.6 Flange assembly

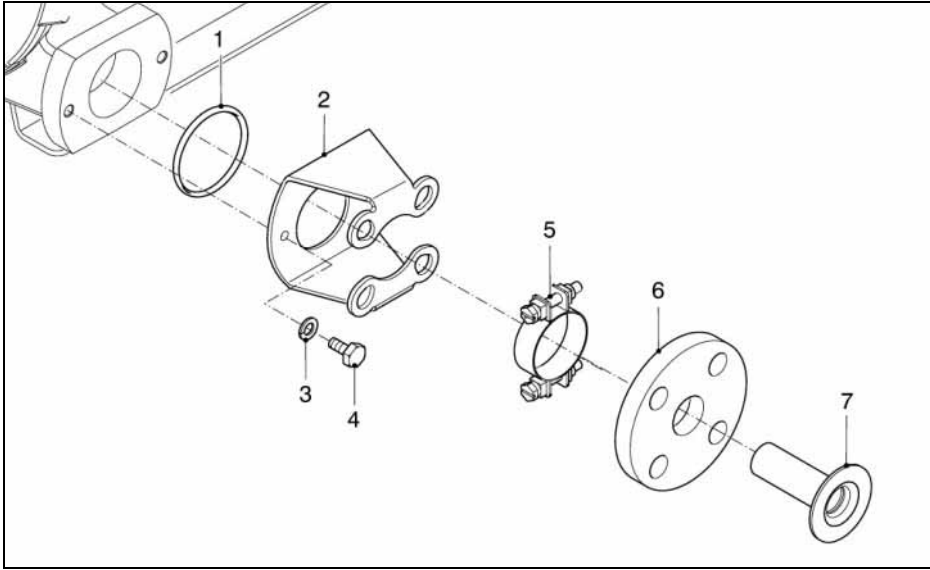

| Pos. | Qty. | Description | Product codes for parts of pump type | |
|------|------|--------------------------|--------------------------------------|--------------|
| | | | DuCoNite® 25 | DuCoNite® 32 |
| 1 | 2 | O-ring | S112233 | S112273 |
| 2 | 2 | Flange bracket | 225197A | 232197A |
| 3 | 4 | Washer, Spring Lock, M10 | F532010 | F532010 |
| 4 | 4 | Bolt, hex. head, M10X25 | F504075 | F504075 |
| 5 | 2 | Hose clamp | C101572 | C101573 |
| 6 | 2 | Flange, DIN SS | 225199 | 232199 |
| | | Flange, ANSI SS | 225199A | 232199A |
| 7 | 2 | Insert, Stainless steel | 025186 | 032186 |
| | | Insert, PVC | 025187 | 032187 |
| | | Insert, PP | 025189 | 032189 |
| | | Insert, PVDF | 025190 | 032190 |

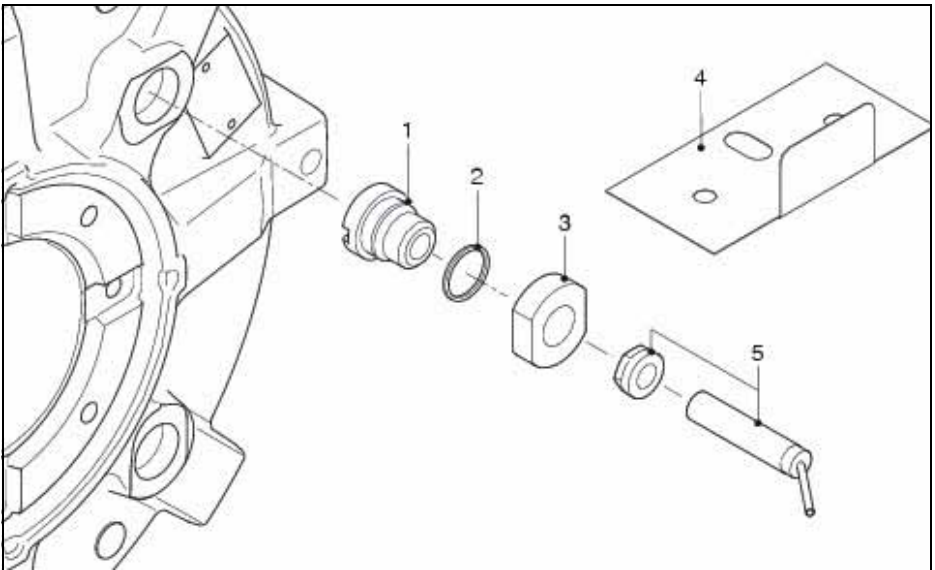
10.6.7 Revolution counter assembly

| Pos. | Qty. | Description | Product codes for parts of pump type | |
|------|------|-------------------------|--------------------------------------|--------------|
| | | | DuCoNite® 25 | DuCoNite® 32 |
| 1 | 1 | Plug | 29029457 | 29029457 |
| 2 | 1 | O-ring | S120183 | S120183 |
| 3 | 1 | Nut | 29035458 | 29035458 |
| 4 | 1 | Revolution counter shim | 225107NS | 232107NS |
| 5 | 1 | Revolution counter | 29050368 | 29050368 |

10.6.8 Lubricants

| Pos. | Qty. | Description | Product codes for parts of pump type | |
|------|------|---------------------------------------|--------------------------------------|--------------|
| | | | DuCoNite® 25 | DuCoNite® 32 |
| 1 | 1 | 3 l can Bredel Genuine Hose Lubricant | 908143 | - |
| | 1 | 5 l can Bredel Genuine Hose Lubricant | - | 903143 |

SAFETY FORM

Product Use and Decontamination Declaration

In compliance with the **Health and Safety Regulations**, the user is required to declare those substances that have been in contact with the item(s) you are returning to Watson-Marlow Bredel B.V. or any of its subsidiaries or distributors. Failure to do so will cause delays in servicing the item or in issuing a response. Therefore, **please complete this form** to make sure we have the information before receipt of the item(s) being returned. A completed copy must be attached to **the outside of the packaging** containing the item(s). You, the user, are responsible for cleaning and decontaminating the item(s) before returning them.

Please complete a separate Decontamination Certificate for each item returned. **RGA/KBR no**.....

1 Company

Address

Postal code.....

Telephone Fax number

2 Product 3.4 Cleaning fluid to be used if residue of chemical is found during servicing;

2.1 Serial Number

2.2 Has the Product been used? a)

YES NO b)

If yes, please complete all the following paragraphs. c)

If no, please complete paragraph 5 only d)

3 Details of substances pumped 4 I hereby confirm that the only substances(s) that the equipment specified has pumped or come into contact with are those named, that the information given is correct, and the carrier has been informed if the consignment is of a hazardous nature.

3.1 Chemical Names

a)

b)

c)

d)

3.2 Precautions to be taken in handling these substances: 5 Signed

a)

b)

c)

d)

Name

Position

Date

3.3 Action to be taken in the event of human contact:

a)

b)

c)

d)

Note:

To assist us in our servicing please describe any fault condition you have witnessed.

.....

.....

.....

Watson-Marlow Pumps Group
37 Upton Technology Park
Wilmington, MA 01887
USA

Telephone: 800 - 282 - 8823
978 - 658 - 6168

Fax: 978 - 658 - 0041

Internet: www.wmpg.com

E-mail: support@wmpg.us



© 2013 Watson-Marlow Bredel B.V.