

# IPA 65

*Inlet pulse accumulator*

**Bredel**

*Hose Pumps*

## Features and benefits

- Reduces positive and negative peaks when inlet conditions vary
- Eliminates up to 90 % of the pump inlet pulsation
- Provides quieter operation and maximises hose life
- Low maintenance set-up, suitable for any Bredel and APEX pump with hose size from 25 mm (1") to 100 mm (4")
- Safe handling



## Technical specifications

	IPA 65
Max. operating pressure	6 bar
Max. operating pressure	87 psi
Storage temperature range	-40 °C to 70 °C
Storage temperature range	-40 °F to 158 °F
Product temperature range	-10 °C to 80 °C
Product temperature range	14 °F to 176 °F

## Materials of construction

	IPA 65
Hose material	EPDM, Natural rubber (NR), NBR
Housing assemblies	PVC, Stainless steel 316
O-ring	NBR
Flange materials	PVC, Stainless steel 316

## IPA 65 dimensions

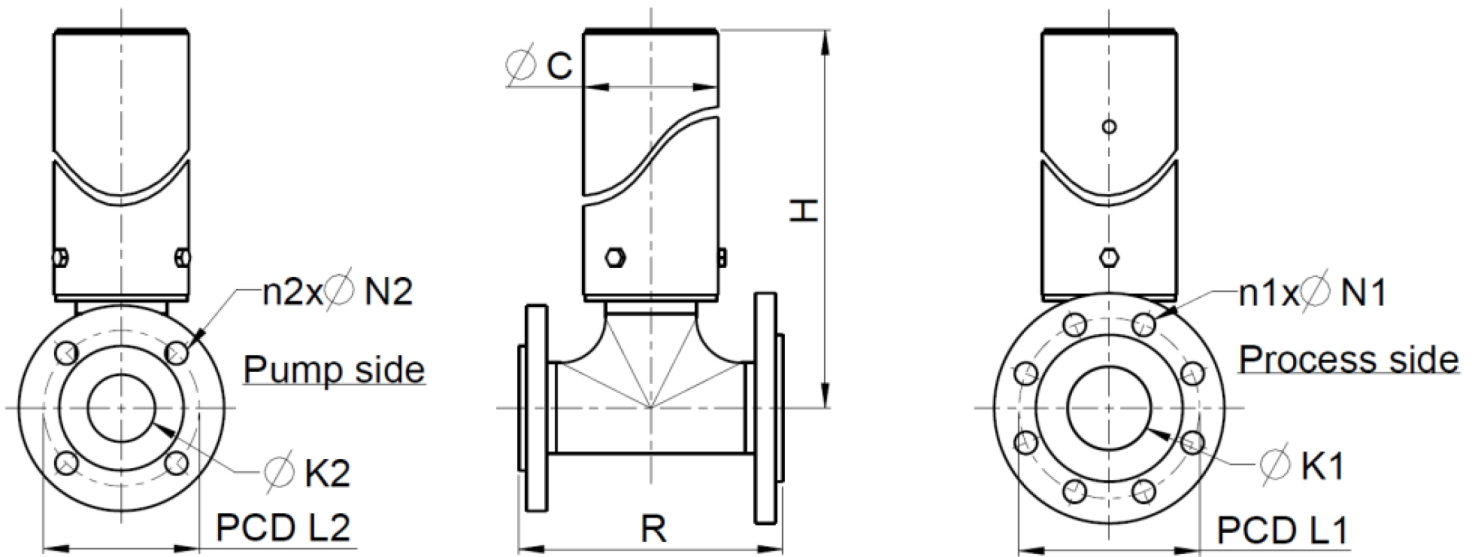

Dimensions in mm (for DIN/EN flanges)												
IPA Type	Pump Type	C	SS	PVC	DIN/EN			DIN/EN			SS	PVC
			H	H	K1	L1	$n1 \times N1$	K2	L2	$n2 \times N2$	R	R
IPA65	Bredel 50	108	511	513	DN65	145	8 x 18*	DN50	125	4 x 18	212	270
IPA65	Bredel 65	108	694	696	DN65	145	8 x 18*	DN65	145	8 x 18*	212	270

Dimensions in inches (for ANSI flanges)												
IPA Type	Pump Type	C	SS	PVC	ANSI			ANSI			SS	PVC
			H	H	K1	L1	$n1 \times N1$	K2	L2	$n2 \times N2$	R	R
IPA65	Bredel 50	4.3	20.1	20.2	2 1/2	5 1/2	8 x 3/4	2	4 3/4	4 x 3/4	8.3	10.6
IPA65	Bredel 65	4.3	27.3	27.4	2 1/2	5 1/2	8 x 3/4	2 1/2	5 1/2	8 x 3/4	8.3	10.6

## Product codes

Replacement hose element			Part number	
Hose type	Material	Colour code	IPA65/50	IPA65/65
NR	Natural rubber	Purple	28-IP06505020	28-IP06506520
NBR	Nitrile rubber	Yellow	28-IP06505040	28-IP06506540
EPDM	EPDM	Red	28-IP06505075	28-IP06506575

For ordering please advise:

1. Flange size and type
2. Pump size and type
3. Required material for hose
4. Required material for T-piece and flanges

For further information on Inlet Pulse Accumulators please contact your Bredel representative.

Disclaimer: The information contained in this document is believed to be correct at the time of publication, but Watson-Marlow Bredel BV accepts no liability for any error it contains, and reserves the right to alter specifications without prior notice. All mentioned values in this document are values under controlled circumstances at our test bed. Actual flow rates achieved may vary because of changes in temperature, viscosity, inlet and discharge pressures and/or system configuration. APEX, DuCoNite, Bioprene and Bredel are registered trademarks.

[wmfts.com/global](http://wmfts.com/global)



12 July 2024