

Divert valves

Divert valves

Features and benefits

- Accommodates our contamination-free clamp assembly technology making the valves easy to fit in place, inspect and maintain
- Designed to allow division and blending of up to three lines in a single valve body
- Flush mount design
- Simple clamp assembly
- Change diaphragms in seconds
- Minimizes distances between each valve seat (fewer and shorter dead legs)
- Self-draining with full CIP/SIP capability
- Available valve sizes: 0.5", 1.0", 2.0", 2.5", and 3.0"



Divert valves performance

Divert valve flow rates		
Size	Cv at 1 psi (0.07 bar)	
inches	GPM	LPM
0.50	4.3	16.3
1.00	15.8	59.8
1.50 (True)	48	182
1.50	56	212
2.00	72	273
2.50	90	341
3.00	170	643

Technical specifications

	Divert valves
Mounting type	Flush
Flow rate	16.3 - 643 l/m
Flow rate	4.3 - 170 USGPM
Sizes	0.5", 1.0", 1.5", 2.0", 2.5", 3.0"
Outlet connections	Buttweld, Sanitary flange
Max. operating pressure	17 bar
Max. operating pressure	250 psi
Operating temperature range	-51 °C to 177 °C
Operating temperature range	-60 °F to 350 °F
Compatible actuators	Autoclavable manual, Compact, Normally closed pneumatic, Normally open pneumatic
Compatible diaphragms	EPDM, PTFE, Silicone, Silicone plus, Viton
Surface finish options	Electropolished, Max 10 micro-inch Ra (0.25 µm Ra), Max 15 micro-inch Ra (0.375 µm Ra), Max 20 micro-inch Ra (0.5 µm Ra)
Certification and compliance	ISO 9001
Standards	ASME BPE, CE-PED
Weight	0.9 - 17 kg
Weight	1.9 - 37.5 lbs

Materials of construction

Divert valves	
Material	Hastelloy C22, Hastelloy C276, Polypropylene, Stainless steel 316L, Stainless steel AL-6XN

Divert valves dimensions

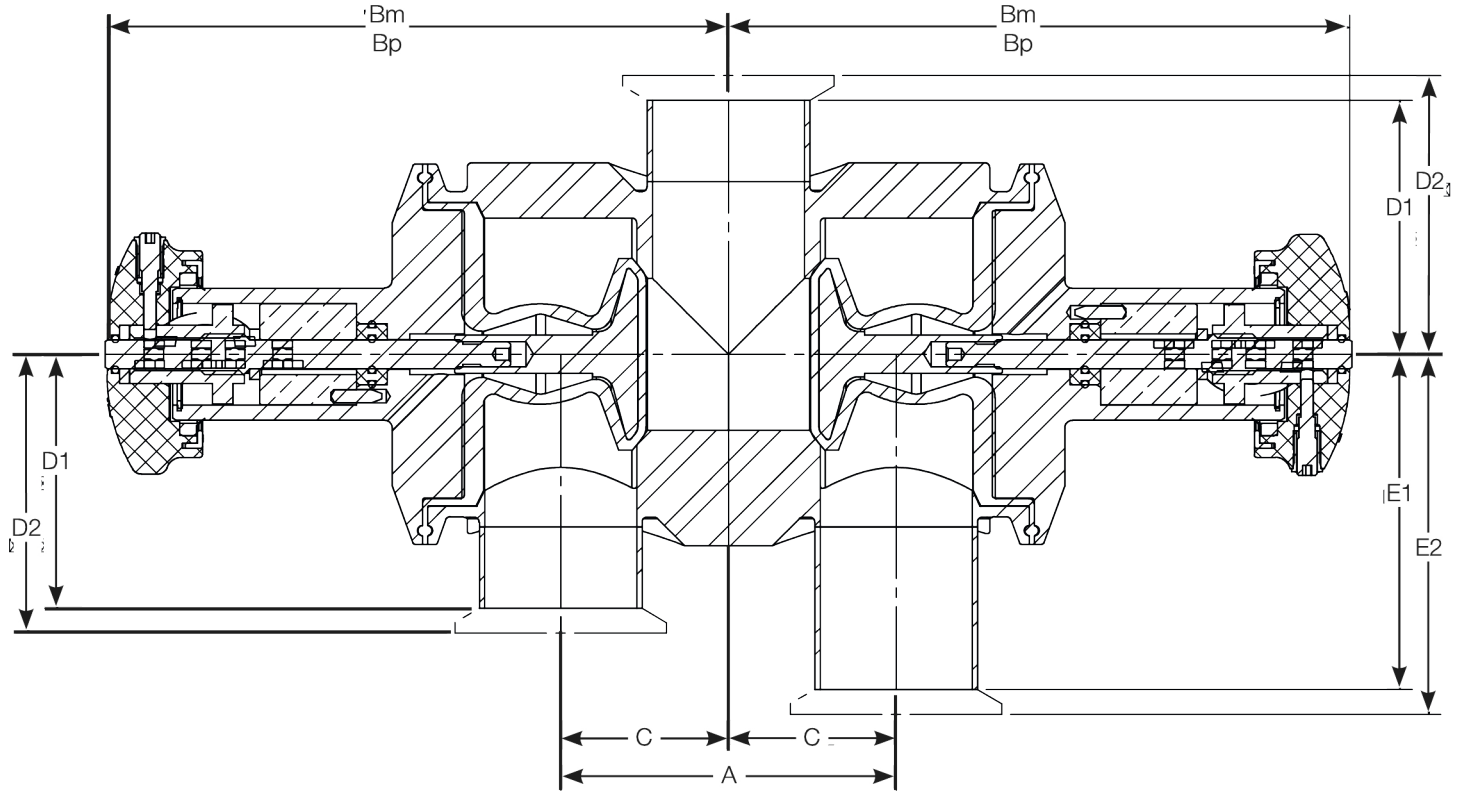

Size	A		Bm - with Manual Actuator		C		Bp - with Pneumatic Actuator		D1 Weld-End Fitting		D2 Clamp-End Fitting		E1 Weld-End Fitting		E2 Clamp-End Fitting	
	mm	in	mm	in	mm	in	mm	in	mm	in	mm	in	mm	in	mm	in
0.50	39	1.55	105	4.13	124	0.77	20	4.90	50	1.96	53	2.08	75	2.96	78	3.08
1.00	54	2.13	128	5.05	169	1.06	27	6.66	61	2.40	64	2.53	86	3.40	89	3.53
1.50 (True)	80	3.13	142	5.60	188	1.56	40	7.41	68	2.67	71	2.79	93	3.67	96	3.79
1.50	105	4.13	188	7.39	210	2.06	52	8.25	82	3.22	85	3.35	107	4.22	110	4.35
2.00	188	7.40	194	7.64	216	3.70	94	8.50	80	3.13	83	3.25	105	4.13	108	4.25
2.50	163	6.41	230	9.07	290	3.25	83	11.42	91	3.59	94	3.71	117	4.59	120	4.71
3.00	152	6.00	230	9.07	290	3.00	76	11.42	91	3.59	94	3.71	117	4.59	120	4.71

Weights

Size	Valve Body		Total Weight with Pneumatic Actuator				Total Weight with Manual Actuator	
	Kg	lb	Kg		lb		Kg	lb
0.50	0.9	1.9	1.7		3.6		1.6	3.8
1.00	2.3	5.0	4.2		10.0		4.5	9.2
1.50 (True)	4.3	9.5	5.9		14.5		6.6	13.1
1.50	7.9	17.5	10.9		25.9		11.7	24.0
2.00	8.4	18.5	11.3		36.9		16.7	25.0
2.50	17.0	37.5	20.2		61.2		27.7	44.5
3.00	16.8	37	19.9		60.7		27.5	44

Product codes

Size	Model code	Description
0.5	DV05-706-1	Radial valve 0.5" Divert Double-valve EN 1.4435 body/EN1.4404 fittings 0.5" Clamp-end Spool 0.487" long 0.5" clamp-end outlet 2.96" from centerline Flush diaphragm & 0.5" clamp-end port 2.08" from centerline Flush diaphragm at 180 ° 0.5" clamp-end outlet 2.08" from centerline Flush diaphragm 20 micro-inch Ra surface finish electropolished and passivated includes body/actuator clamp
1.0	DV05-706-2	Radial valve , 0.5" Divert, Double-valve EN 1.4435 body/EN1.4404 fitting(s), 0.5" Clamp-end Spool, 1.625" long, 0.5" clamp-end outlet, 2.96" from centerline, Flush diaphragm, & 0.5" clamp-end port, 2.08" from centerline, Flush diaphragm at 180 °, 0.5" clamp-end outlet 2.08" from centerline Flush diaphragm 15 micro-inch Ra surface finish, electropolished and passivated, includes body/actuator clamp
1.50 (True)	DV05-706-3	Radial valve 0.5" Divert Double-valve 316L/EN1.4404 0.5" Clamp-end 0.487" 0.5" clamp-end outlet 2.96" from centerline Flush diaphragm & 0.5" clamp-end port 2.08" from centerline Flush diaphragm at 180 ° 0.5" clamp-end outlet 2.08" from centerline Flush diaphragm 10 micro-inch Ra surface finish electropolished and passivated includes body/actuator clamp
1.5	DV17-101-1	Radial valve 1.5" Divert Double-valve EN 1.4435 body/EN1.4404 fittings 1.5" Clamp-end Spool 0.487" long 1.5" clamp-end outlet 2.8" from centerline Flush diaphragm & 1.5" clamp-end port 2.8" from centerline Flush diaphragm at 180 ° 1.5" clamp-end outlet 2.8" from centerline Flush diaphragm 20 micro-inch Ra surface finish electropolished and passivated includes body/actuator clamp
2.0	DV17-105-1	Radial valve , 1.5" Divert, EN 1.4435 body/EN1.4404 fitting(s), Spool, 1.5" Clamp-end inlet 2.8" from centerline, 1.5" clamp-end outlet, 4.2" from centerline with 0.75" condensate, Flush diaphragm, & 1.5" clamp-end port, 4.2" from centerline with 0.75" condensate, Flush diaphragm at 180 °, 20 micro-inch Ra surface finish, electropolished and passivated includes body/actuator clamp
2.5	DV17-105-2	Radial valve , 1.5" Divert, EN 1.4435 body/EN1.4404 fitting(s), Spool, 1.5" Clamp-end inlet 2.8" from centerline, 1.5" clamp-end outlet, 4.2" from centerline with 0.75" condensate, Flush diaphragm, & 1.5" clamp-end port, 4.2" from centerline with 0.75" condensate, Flush diaphragm at 180 °, 15 micro-inch Ra surface finish, electropolished and passivated includes body/actuator clamp
3.0	DV20-705-1	Radial valve 2" Divert Double-valve EN 1.4435 body/EN1.4404 fittings 2" Clamp-end Spool 3.25" long 2" clamp-end outlet 3.25" from centerline Flush diaphragm 2" clamp-end outlet 3.25" from centerline Flush diaphragm 20 micro-inch Ra surface finish electropolished and passivated includes body/actuator clamp

Disclaimer: The information contained in this document is believed to be correct but ASEPCO accepts no liability for any errors it contains and reserves the right to alter specifications without notice. It is the user's responsibility to ensure product suitability for use within their application. Radial diaphragm is a trademark of ASEPCO Corporation. Tri-Clamp is a registered trademark of Alfa Laval Corporate AB. A member of Watson-Marlow Fluid Technology Solutions, A Spirax-Sarco Engineering plc company.

wmfts.com/global



01 August 2024