

Features and benefits

- Radial diaphragm - eliminates entrapment for easy cleaning
- Fully drainable within a 180 degree range of installation angles
- Simple, Tri-Clamp assembly makes maintenance 80 % faster compared to a weir type valve
- Integrated travel stops
- No readjustment or retightening



Inline valves performance

Performance			
		Cv (gpm)	Kv (m3/h) Kv = .865Cv
ASME BPE	0.5"	2.94	2.54
	0.75"	8.00	6.92
	1"	16.96	14.67
	1.5"	43.78	37.87
DIN 11866 DIN 32676 Series A	DN 10 A	2.94	2.54
	DN 15 A	8.00	6.92

Technical specifications

	Inline valves
Mounting type	Clamp, Weld-in
Flow rate (Cv)	2.94 - 43.78 gpm
Flow rate (Kv)	2.54 - 37.87 m ³ /h
Mounting sizes	0.5 in, 0.75 in, 1.0 in, 1.5 in, DN 10 A, DN 15 A
Max. operating pressure	10 bar
Max. operating pressure	150 psi
Operating temperature range	-35 °C to 135 °C
Operating temperature range	-30 °F to 275 °F
Compatible actuators	Fail closed, Manual, Pneumatic
Compatible diaphragms	EPDM, Silicone
Surface finish options	Electropolished, Inner: Max. 15 µin Ra (0.38 µm), Outer: Max. 32 µin Ra (0.8 µm)
Certification and compliance	ISO 9001
Standards	ASME BPE, ASME BPVC, CE-PED
Weight	0.12 - 1.1 kg
Weight	0.27 - 2.43 lbs

Materials of construction

	Inline valves
Material	Stainless steel 316L

Inline valves dimensions

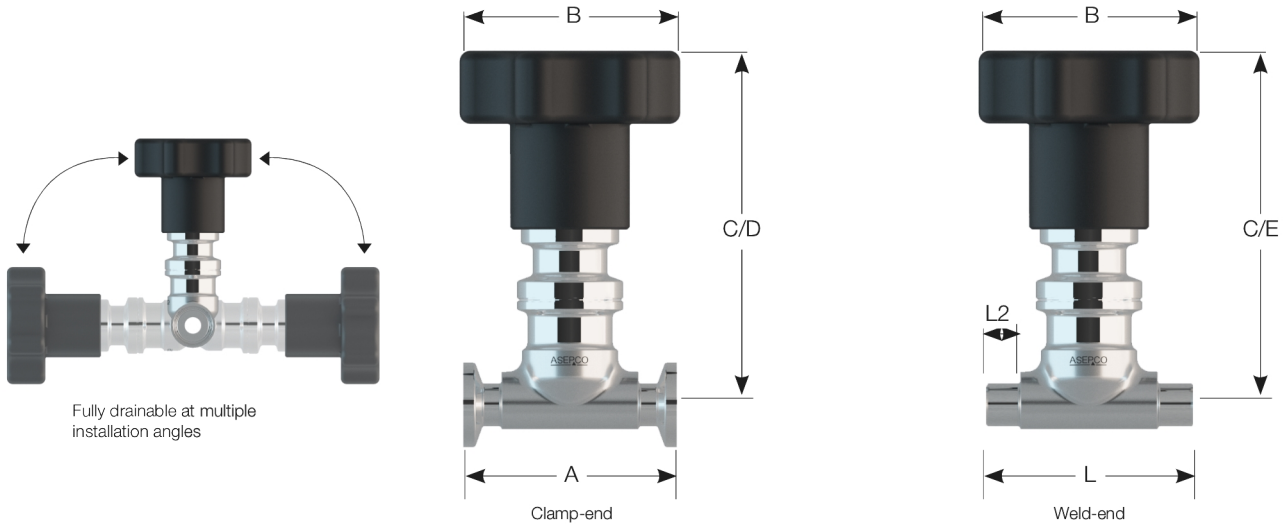

Dimensions									
Size		A mm (inch)	L mm (inch)	L2 mm (inch)	B - with manual actuator mm (inch)	B - with pneumatic actuator mm (inch)	C - with manual actuator mm (inch)	D - with pneumatic actuator mm (inch)	E - with pneumatic actuator mm (inch)
ASME BPE	0.5"	63.5 (2.5)	81.0 (3.19)	20.1 (0.79)	66.4 (2.6)	45.7 (1.8)	100.5 (4.0)	149.9 (5.9)	149.9 (5.9)
	0.5"	101.6 (4.0)	104.8 (4.13)	20.4 (0.80)	66.4 (2.6)	85.8 (3.4)	100.5 (4.0)	170.0 (6.7)	170.0 (6.7)
	1"	114.3 (4.5)	114.3 (4.5)	20.7 (0.81)	66.4 (2.6)	85.8 (3.4)	119.7 (4.7)	189.4 (7.5)	189.4 (7.5)
	1.5"	139.7 (5.5)	139.7 (5.5)	22.2 (0.87)	66.4 (2.6)	105.0 (4.1)	126.0 (5.0)	207.5 (8.2)	207.5 (8.2)
DIN 11866	DN 10 A	108.0 (4.25)	108.0 (4.25)	33.6 (1.32)	66.4 (2.6)	45.7 (1.8)	101.0 (4.0)	150.0 (5.9)	150.0 (5.9)
DIN 32676 Series A	DN 15 A	108.0 (4.25)	108.0 (4.25)	21.9 (0.86)	66.4 (2.6)	85.8 (3.4)	101.0 (4.0)	170.5 (6.7)	170.5 (6.7)

C, D and E dimension shown when valve is in closed position All dimensions are for reference only

Weights

Size	Connection	Valve body weight		Assembly weight			
		lbs	kg	Weight with manual actuator (lbs)	Weight with manual actuator (kg)	Weight with pneumatic actuator (lbs)	Weight with pneumatic actuator (kg)
ASME BPE	0.5" Clamp-end	0.30	0.13	1.5	0.67	1.7	0.76
	0.5" Weld-end	0.27	0.12	1.4	0.65	1.6	0.75
	0.75" Clamp-end	0.64	0.29	2.1	0.97	3.1	1.41
	0.75" Weld-end	0.62	0.28	2.1	0.96	3.1	1.40
	1" Clamp-end	1.36	0.62	3.5	1.58	4.4	2.02
	1" Weld-end	1.13	0.51	3.2	1.47	4.2	1.91
	1.5" Clamp-end	2.53	1.15	7.2	3.25	9.3	4.22
	1.5" Weld-end	2.43	1.10	7.1	3.20	9.2	4.17
DIN 11866 DIN 32676 Series A	DN 10 A Clamp-end	0.47	0.21	1.6	0.75	1.8	0.84
	DN 10 A Weld-end	0.27	0.12	1.4	0.65	1.6	0.75
	DN 15 A Clamp-end	0.80	0.36	2.3	1.04	3.3	1.48
	DN 15 A Weld-end	0.61	0.28	2.1	0.96	3.1	1.40

Product codes

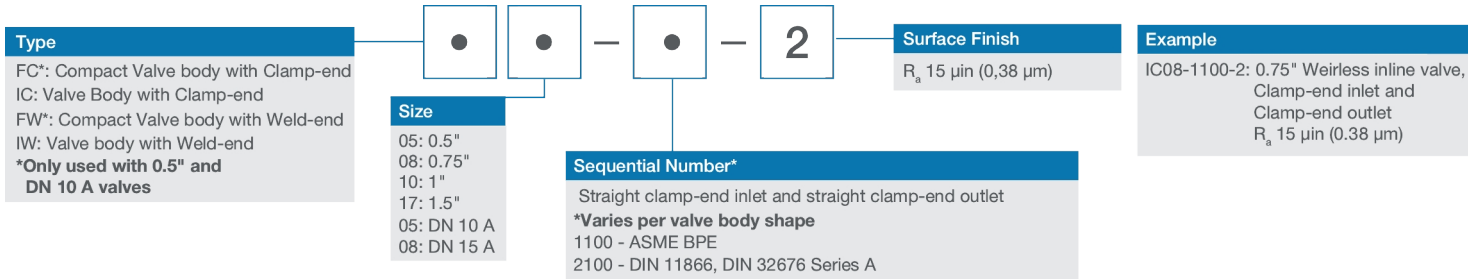

Disclaimer: The information contained in this document is believed to be correct but ASEPCO accepts no liability for any errors it contains and reserves the right to alter specifications without notice. It is the user's responsibility to ensure product suitability for use within their application. Radial diaphragm is a trademark of ASEPCO Corporation. Tri-Clamp is a registered trademark of Alfa Laval Corporate AB. A member of Watson-Marlow Fluid Technology Solutions, A Spirax-Sarco Engineering plc company.

wmfts.com/global



01 August 2024