

Watson-Marlow 520BpN/520Bp PROFIBUS-controlled pumps



Contents

1	Declaration of conformity	3	19	Pin-out details	47
2	Declaration of incorporation	3	20	MemoDose	49
3	Five-year warranty	4	20.1	Changing dosing speed	50
4	When you unpack your pump	5	21	Exit	51
5	Information for returning pumps	6	22	PROFIBUS network control wiring and leak detection device wiring	52
6	Peristaltic pumps: an overview	7	22.1	520N module removal and replacement	52
7	Safety notes	8	22.2	Wiring up	54
8	Pump specifications	10	22.2.1	PROFIBUS wiring	54
8.1	Dimensions	16	22.2.2	Leak detection wiring	56
9	Good pump installation practice	17	23	Switching to PROFIBUS network control	57
9.1	General recommendations	17	23.1	PROFIBUS GSD file	58
9.2	Do's and do not's	17	23.2	PROFIBUS data exchange	60
10	Connecting this product to a power supply	19	23.3	PROFIBUS network operation	62
11	Start-up check list	22	24	Troubleshooting	62
12	Switching the pump on for the first time	22	24.1	Error codes	63
13	Switching the pump on in subsequent power cycles (if not in auto-restart mode)	24	25	Drive maintenance	64
14	Manual operation	25	26	Drive spares	64
14.1	Keypad functions in manual mode	25	27	The 505L pumphead	65
14.2	Keypad lock	28	27.1	505L pumphead fitting and removal	65
14.3	Keypad beep	28	28	505L tube loading	67
15	Main menu	29	28.1	505L: fitting double-Y tubing elements	68
15.1	Keypad functions in menu screens	29	28.2	505L: using twin inlet tubes	70
15.2	Main menu entry	30	28.3	505L: using two independent tubes	71
16	Pin-secure process protection	31	29	505L maintenance	72
17	Calibrate	32	30	505L track adjustment	73
18	Setup	36	31	505L pumphead spares	73
18.1	Pump address	37	32	505L flow rates	74
18.2	PROFIBUS enable	37	33	505L tubing part numbers	75
18.3	Display	38	34	The 520R, 520R2 and 520RE pumpheads	76
18.4	Flow units	39	34.1	Pumphead position, removal and replacement	77
18.5	Run time	40			
18.6	Auto-restart	41			
18.7	Set maximum speed	42			
18.8	Backlight	42			
18.9	ROM	43			
18.10	Language	43			
18.11	Defaults	44			
18.12	Beep	44			
18.13	Security code	45			
18.14	Exit	46			

35	520R, 520R2 and 520RE installation	79	38	520R, 520R2 and 520RE pumphead spares	87
35.1	Opening the pumphead guard	79	39	520R, 520R2 and 520RE flow rates	88
35.2	520R and 520R2 tube loading	80	40	520R, 520R2 and 520RE: tubing and element part numbers	96
35.3	520RE: fitting the drain port	81	41	520 series pumping accessories	99
35.4	520RE element loading	82	42	Trademarks	100
35.5	520RE element connection	84	43	Patient-connected applications	100
36	520R, 520R2 and 520RE maintenance	85	44	Publication history	100
37	520R, 520R2 and 520RE rotor settings	86	45	Decontamination certificate	101

BpN, Bp

1 Declaration of conformity



This declaration was issued for Watson-Marlow 520BpN and 520Bp pumps on September 1, 2008. When this pump unit is used as a stand-alone pump it complies with: Machinery Directive 2006/42/EC, EMC Directive 2004/108/EC.



This pump is ETL listed: ETL control number 3050250. Cert to CAN/CSA std C22.2 No 61010-1. Conforms to UL std 61010A-1.

See 8 Pump specifications.

BpN, Bp

2 Declaration of incorporation

When this pump unit is to be installed into a machine or is to be assembled with other machines for installations, it must not be put into service until the relevant machinery has been declared in conformity with the Machinery Directive 2006/42/EC.

A handwritten signature in black ink, appearing to read 'C. Gadsden'.

Responsible person: Christopher Gadsden, Managing Director, Watson-Marlow Limited, Falmouth, Cornwall TR11 4RU, England. Telephone +44 (0) 1326 370370 Fax +44 (0) 1326 376009.

The information in this user guide is believed to be correct at the time of publication. However, Watson-Marlow Limited accepts no liability for errors or omissions. Watson-Marlow Bredel has a policy of continuous product improvement, and reserves the right to alter specifications without notice. This manual is intended for use only with the pump it was issued with. Earlier or later models may differ. The most up-to-date manuals appear on the Watson-Marlow website: <http://www.watson-marlow.com>

3 Five year warranty

520 cased pumps, 620 cased pumps and 720 cased pumps

For any 520, 620 or 720 cased pump purchased after 1 January 2007, Watson-Marlow Limited ("Watson-Marlow") warrants, subject to the conditions and exceptions below, through either Watson-Marlow, its subsidiaries, or its authorised distributors, to repair or replace free of charge, any part of the product which fails within five years of the day of manufacture of the product. Such failure must have occurred because of defect in material or workmanship and not as a result of operation of the product other than in normal operation as defined in this pump manual.

Watson-Marlow shall not be liable for any loss, damage, or expense directly or indirectly related to or arising out of the use of its products, including damage or injury caused to other products, machinery, buildings, or property, and Watson-Marlow shall not be liable for consequential damages, including, without limitation, lost profits, loss of time, inconvenience, loss of product being pumped, and loss of production. This warranty does not obligate Watson-Marlow to bear any costs of removal, installation, transportation, or other charges which may arise in connection with a warranty claim.

Conditions of and specific exceptions to the above warranty are:

Conditions

- Products must be returned by pre-arrangement, carriage-paid, to Watson-Marlow, or a Watson-Marlow approved service centre.
- All repairs or modifications must have been made by Watson-Marlow Limited, or a Watson-Marlow approved service centre or with the express permission of Watson-Marlow.
- Warranties purporting to be on behalf of Watson-Marlow made by any person, including representatives of Watson-Marlow, its subsidiaries, or its distributors, which do not accord with the terms of this warranty shall not be binding upon Watson-Marlow unless expressly approved in writing by a Director or Manager of Watson-Marlow.

Exceptions

- The warranty shall not apply to repairs or service necessitated by normal wear and tear or for lack of reasonable and proper maintenance.
- All tubing and pumping elements as consumable items are excluded.
- Products which, in the judgment of Watson-Marlow, have been abused, misused, or subjected to malicious or accidental damage or neglect are excluded.
- Electrical surge as a cause of failure is excluded.
- Chemical attack is excluded
- All pumphead rollers are excluded.
- The 620R family of pumpheads are excluded from all warranty when pumping above 2 bar while above 165rpm.
- Pumpheads from the 313/314 and the Microcassette ranges and any 701 extension pumpheads are excluded and retain their one-year standard pumphead warranty. The drive they are attached to is subject to the five-year warranty as set out here.
- Ancillaries such as leak detectors are excluded.

4 When you unpack your pump

Unpack all parts carefully, retaining the packaging until you are sure all components are present and in good order. Check against the components supplied lists, below.

Packaging disposal

Dispose of packaging materials safely, and in accordance with regulations in your area. Pay particular attention to the expanded polystyrene shockproof shells. The outer carton is made of corrugated cardboard and can be recycled.

Inspection

Check that all components are present. Inspect components for damage in transit. If anything is missing or damaged, contact your distributor immediately.



BpN

Components supplied (520BpN pump, IP66 NEMA 4X models)

- The 520BpN pump drive unit fitted with:
 - 520R2 or other pumphead (See 8 *Pump specifications*) if specified as a pump
 - A 520N module providing pump ingress protection to IP66, NEMA 4X.
 - Note:** the module is attached for transit, but must be removed to allow wiring up, voltage selection and fuse inspection and then re-affixed before the pump is operated.
 - The designated mains power lead for your pump
- PC-readable CDROM containing these operating instructions
- Quick Start manual

Bp

Components supplied (520Bp pump, IP31 models)

- The 520Bp pump drive unit fitted with:
 - 520R2 or other pumphead (See 8 *Pump specifications*) if specified as a pump
 - The designated mains power lead for your pump
- PC-readable CDROM containing these operating instructions
- Quick Start manual

Note: Some versions of this product will include components different from those listed above. Check against your purchase order.

BpN, Bp

Storage

This product has an extended shelf life. However, care should be taken after storage to ensure that all parts function correctly. Users should be aware that the pump contains a battery with an unused life of seven years. Long-term storage is not recommended for peristaltic pump tubing. Please observe the storage recommendations and use-by dates which apply to tubing you may wish to bring into service after storage.

BpN, Bp

5 Information for returning pumps

Equipment which has been contaminated with, or exposed to, body fluids, toxic chemicals or any other substance hazardous to health must be decontaminated before it is returned to Watson-Marlow or its distributor.

A certificate included at the rear of these operating instructions, or signed statement, must be attached to the outside of the shipping carton. This certificate is required even if the pump is unused. See 45 *Decontamination certificate*.

If the pump has been used, the fluids that have been in contact with the pump and the cleaning procedure must be specified along with a statement that the equipment has been decontaminated.

6 Peristaltic pumps - an overview

Peristaltic pumps are the simplest possible pump, with no valves, seals or glands to clog or corrode. The fluid contacts only the bore of a tube, eliminating the risk of the pump contaminating the fluid, or the fluid contaminating the pump. Peristaltic pumps can operate dry without risk.

How they work

A compressible tube is squeezed between a roller and a track on an arc of a circle, creating a seal at the point of contact. As the roller advances along the tube, the seal also advances. After the roller has passed, the tube returns to its original shape, creating a partial vacuum which is filled by fluid drawn from the inlet port.

Before the roller reaches the end of the track, a second roller compresses the tube at the start of the track, isolating a packet of fluid between the compression points. As the first roller leaves the track, the second continues to advance, expelling the packet of fluid through the pump's discharge port. At the same time, a new partial vacuum is created behind the second roller into which more fluid is drawn from the inlet port.

Backflow and siphoning do not occur, and the pump effectively seals the tube when it is inactive. No valves are needed.

The principle may be demonstrated by squeezing a soft tube between thumb and finger and sliding it along: fluid is expelled from one end of the tube while more is drawn in at the other.

Animal digestive tracts function in a similar way.

Suitable applications

Peristaltic pumping is ideal for most fluids, including viscous, shear-sensitive, corrosive and abrasive fluids, and those containing suspended solids. They are especially useful for pumping operations where hygiene is important.

Peristaltic pumps operate on the positive displacement principle. They are particularly suitable for metering, dosing and dispensing applications. Pumps are easy to install, simple to operate and inexpensive to maintain.

7 Safety notes

In the interests of safety, this pump and the tubing selected should only be used by competent, suitably trained personnel after they have read and understood this manual, and considered any hazard involved. If the pump is used in a manner not specified by Watson-Marlow Ltd, the protection provided by the pump may be impaired.

Any person who is involved in the installation or maintenance of this equipment should be fully competent to carry out the work. In the UK this person should also be familiar with the Health and Safety at Work Act 1974.



This symbol, used on the pump and in this manual, means: Caution, refer to accompanying documents.



This symbol, used on the pump and in this manual, means: Do not allow fingers to contact moving parts.



This symbol, used on the pump and in this manual, means: Recycle this product under the terms of the EU Waste Electrical and Electronic Equipment (WEEE) Directive.



Fundamental work with regard to lifting, transportation, installation, starting-up, maintenance and repair should be performed by qualified personnel only. The unit must be isolated from mains power while work is being carried out. The motor must be secured against accidental start-up.



There is a user-replaceable type T2,5A H 250V fuse in the fuseholder in the centre of the switch-plate at the back of the pump. In some countries, the mains power plug contains an additional replaceable fuse. There is a fuse on the interface card which self-resets after five seconds. There are no user-serviceable fuses or parts inside this pump.

There are moving parts inside the pumphead. Before opening the tool-unlockable pumphead guard, ensure that the following safety directions are followed.

- Ensure that the pump is isolated from the mains power.
- Ensure that there is no pressure in the pipeline.
- If a tube failure has occurred, ensure that any fluid in the pumphead has been allowed to drain to a suitable vessel, container or drain.
- Ensure that protective clothing and eye protection are worn if hazardous fluids are pumped.
- Primary operator protection from rotating parts of the pump is provided by the pumphead safeguard. Note that safeguards differ, depending on the type of pumphead. See the Pumpheads sections of this manual: 27 and 34.

This pump must be used only for its intended purpose.

The pump must be accessible at all times to facilitate operation and maintenance. Access points must not be obstructed or blocked. Do not fit any devices to the drive unit other than those tested and approved by Watson-Marlow. Doing so could lead to injury to persons or damage to property for which no liability can be accepted.

If hazardous fluids are to be pumped, safety procedures specific to the particular fluid and application must be put in place to protect against injury to persons.

The exterior surfaces of the pump may get hot during operation. Do not take hold of the pump while it is running. Let it cool after use before handling it. The drive unit must not be run without a pumphead fitted.



This product does not comply with the ATEX directive and must not be used in explosive atmospheres.

8 Pump specifications

Labels fixed to the rear of the pump contain manufacturer and contact details, product reference number, serial number and model details.

BpN

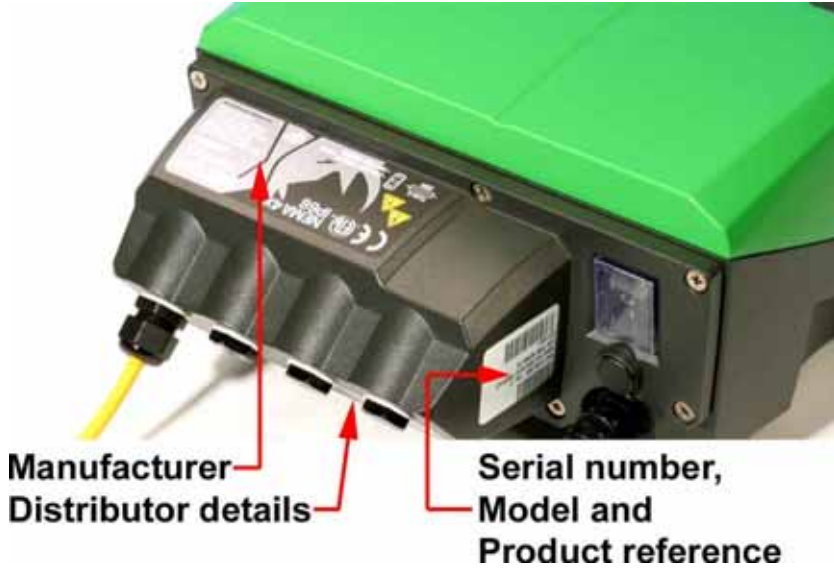

BpN, Bp

The same information is carried on the drive's backplate, accessible when the 520N module is removed.

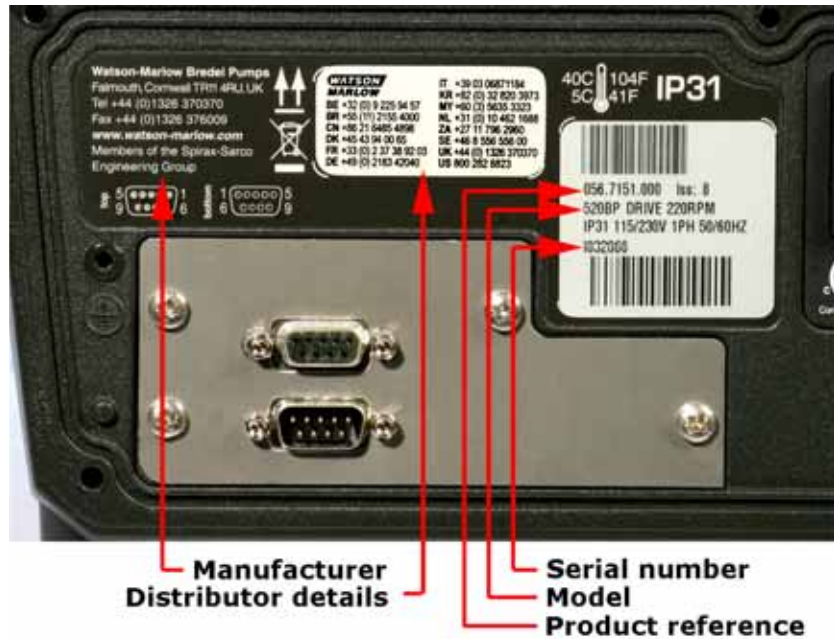

520BpN, IP66 NEMA 4X model and 520Bp, IP31 model

This pump can be controlled from the keypad or remotely. It features:

Manual control

Speed adjustment; run and stop; direction control; keypad scaling; "max" key for rapid priming.

PROFIBUS control

Remote control via PROFIBUS DP V0. See *PROFIBUS digital communications*, below.

MemoDose

Allows precise repeat dosing. Stores in memory a pulse count from the motor. This count is repeated each time **START** is pressed to provide a single-shot dose.

Calibration

Full calibration with default figures for a range of pumpheads and tubes. Calibration dose facility.

PROFIBUS digital communications

PROFIBUS is a system of digital communications widely used in process automation. A central programmable controller—the PROFIBUS master—controls up to 125 devices such as pumps, valves and instruments—slaves. The master can send information to the pump, such as an instruction to start or stop; and interrogate the pump about its condition: whether it is running, for example, or whether it has a fault. Communication is via a dedicated, shielded, two-core cable which connects devices serially to the master.

PROFIBUS/520BpN/520Bp capability

Configuration:

- Set pump address (see 18 *Setup*)
- PROFIBUS enable (see 18 *Setup*)

Parameters:

- Minimum speed (not 520Bp)
- Maximum speed
- Pump model
- Pumphead
- Tubing bore size

Data flow, master to pump:

- Set speed
- Rotation direction
- Start / stop
- Flow calibration

Data flow, pump to master:

- Measured speed
- Running hours
- Tacho count
- Flow calibration

Diagnostics:

- General fault flag
- Pump software version
- PROFIBUS software version
- Leak detection device
- Upper speed limit exceeded
- Lower speed limit exceeded (not 520Bp)

Extended diagnostics:

- Over current
- Over voltage
- Under voltage
- Over temperature
- Stalled
- Tacho fault
- Out of range details

For more information on this pump and PROFIBUS, see 22.2.1 *PROFIBUS wiring* and 23 *Switching to PROFIBUS network control*. Refer to PROFIBUS International for PROFIBUS control information. This product uses a version of PROFIBUS called PROFIBUS Decentralised Periphery V0, and adheres to the International Standard and device certification by PROFIBUS International: <http://www.profibus.com>.

IP (Ingress Protection) and NEMA definitions

IP		NEMA
1st Digit	2nd Digit	
3 Protected against ingress of solid objects with a diameter of more than 2.5mm. Tools, wires etc with a thickness of more than 2.5mm are prevented from approach	1 Protection against dripping water falling vertically. No harmful effect must be produced	2 Indoor use to provide a degree of protection against limited amounts of falling water and dirt
5 Protected against harmful dust deposits. Ingress of dust is not totally prevented but the dust must not enter in sufficient quantity to interfere with satisfactory operation of the equipment. Complete protection against contact	5 Protection against water projected from a nozzle against the equipment (enclosure) from any direction. There must be no harmful effect (water jet)	12 Indoor use to provide a degree of protection against dust, falling dirt and dripping, non-corrosive liquids
		13 Indoor use to provide a degree of protection against dust and spraying water, oil and non-corrosive coolants
6 Protection against ingress of dust (dust-tight). Complete protection against contact	6 Protection against heavy seas or powerful water jets. Water must not enter the equipment (enclosure) in harmful quantities (splashing over)	4X Indoor or outdoor* use to provide a degree of protection against splashing water, wind-blown dust and rain, hose-directed water; undamaged by the formation of ice on the enclosure. (Resist corrosion: 200-hour salt spray)

* 520N cased pumps are rated to NEMA 4X (indoor use) only.

Pump specifications

Control range (turndown ratio)	0.1-220rpm (2,200:1)
Supply voltage/frequency	100-120V/200-240V 50/60Hz 1ph
Maximum voltage fluctuation	±10% of nominal voltage. A well regulated electrical mains supply is required along with cable connections to the best practice of noise immunity
Installation category (overvoltage category)	II
Power consumption	135VA
Full load current	<0.6A at 230V; <1.25A at 115V
Eprom version	Accessible through pump software
Enclosure rating: 520BpN	IP66 to BS EN 60529; Equivalent to NEMA 4X to NEMA 250* (indoor use). Suitable for heavy industrial, process and filthy environments. The drive uses a Gore membrane vent to equalise the pressure inside the enclosure and to prevent ingress of water and corrosive vapours.
Enclosure rating: 520Bp	IP31 to BS EN 60529. Equivalent to NEMA 2, suitable for indoor use. Protected against dripping water and falling dirt. May be wiped with a damp cloth, but should not be immersed.
Pumphead options	520R, 501RL, 313, 314, 505L, 505BA, 505CA, 314MC, 318MC
Operating temperature range	5C to 40C, 41F to 104F
Storage temperature range	-40C to 70C, -40F to 158F
Maximum altitude	2,000m, 6,560ft
Humidity (non-condensing)	80% up to 31C, 88F, decreasing linearly to 50% at 40C, 104F
Pollution degree	2

* Protect from prolonged UV exposure.

Note: 520 drive models are C ETL US listed. Cert to std CAN/CSA C22.2 No 1010-92. Conforms to std UL 61010A-1 April 30, 2002.

Note: 520 drive models have been tested in accordance with BS EN 61000-6-2: 2001 (EN 61000-4-4) Fast Transient and Burst Tests to Industrial limits – ie: Level 3: 2kV.

Standards

EC harmonised standards	Safety of machinery—electrical equipment of machines: BS EN 60204-1
	Safety requirements for electrical equipment for measurement, control and laboratory use: BS EN 61010-1 incorporating A2 Category 2, Pollution degree 2
	Degrees of protection provided by enclosures (IP code): BS EN 60529 amendments 1 and 2
	Conducted emissions: BS EN 55011 A1 and A2 Class A, called by BS EN61000-6-4
	Radiated emissions: BS EN 55011 A1 and A2 Class A, called by BS EN61000-6-4
	Electrostatic discharge: BS EN 61000-4-2
	Radiated RF immunity: BS EN 61000-4-3 A1 and A2, called by BS EN 61000-6-2
	Fast transient burst: BS EN 61000-4-4 A1 and A2, Level 3 (2kV), called by BS EN 61000-6-2
	Surge immunity: BS EN 61000-4-5 A1 and A2, called by BS EN 61000-6-2
	Conducted RF immunity: BS EN 61000-4-6, called by BS EN 61000-6-2
	Voltage dips and interruptions: BS EN 61000-4-11, called by BS EN 61000-6-2
	Mains harmonics: BS EN 61000-3-2 A2
	Pumps and pump units for liquids—common safety requirements: BS EN 809
	Other standards
CAN/CSA-C22.2 No 61010-1	
Conducted emissions FCC 47CFR, Part 15.107	
Radiated emissions FCC 47CFR, Part 15	
NEMA 4X to NEMA 250 (indoor use) for IP66 products only PROFIBUS Certificate	

8.1 Dimensions

520BpN IP66/NEMA 4X model and 520Bp IP31 models; 520R pumphead



520BpN IP66/NEMA 4X model and 520Bp IP31 models; 505L pumphead

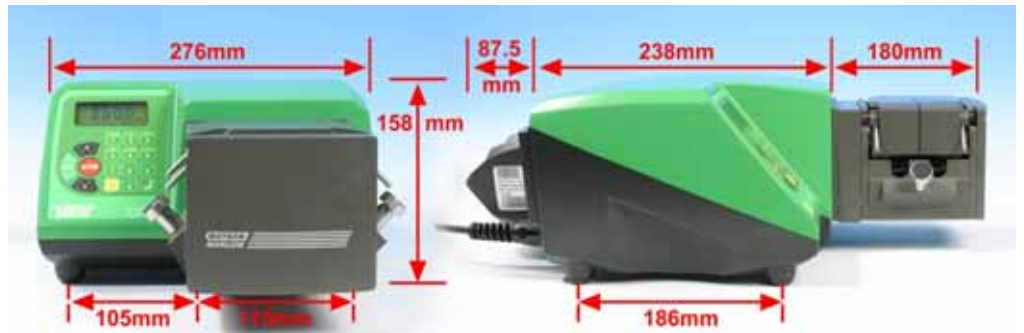

Note: 520BpN and 520Bp pumps are the same size except that the 520Bp lacks the 520N module at the rear of the pump.

Unit weights

	Drive only	+ 520R, 520R2	+ 520REL, 520REM, 520REH	+ 505L
520BpN: IP66, NEMA 4X	10.58kg 23lb 5oz	11.48kg 25lb 5oz	11.40kg 25lb 2oz	13.06kg 28lb 13oz
520Bp: IP31	9.70kg 21lb 6oz	10.60kg 23lb 5oz	10.52kg 23lb 3oz	12.18kg 26lb 14oz

9 Good pump installation practice

9.1 General recommendations

A correctly engineered installation will promote long tube life. Site the pump on a flat, horizontal, rigid surface, free from excessive vibration, to ensure correct lubrication of the gearbox. Allow a free flow of air around the pump to ensure that heat can be dissipated. Ensure that the ambient temperature around the pump does not exceed 40C.

The **STOP** key on the keypad will always stop the pump. However, it is recommended that a suitable local emergency stop device is fitted into the mains supply to the pump.

Do not stack pumps more than three high. When pumps are stacked, ensure that the ambient temperature around all the pumps in the stack does not exceed 40C.

The pump may be set up so that the direction of rotor rotation is clockwise or counter-clockwise, whichever is convenient. Please note, however, that for the 520R and 501RL pumpheads tube life will be greater if the rotor rotates clockwise; and that performance against pressure will be maximised if the rotor rotates counter-clockwise. To achieve 4 bar and 7 bar pressures using a 520RE pump and the appropriate rotor and element, the pump **must** rotate counter-clockwise.

Peristaltic pumps are self-priming and self-sealing against backflow. No valves are required in inlet or discharge lines, except as described below. Valves in the process flow must be opened before the pump operates. Users are advised to fit a pressure relief device between the pump and any valve on the discharge side of the pump to protect against damage caused by accidental operation with the discharge valve closed. Users of 520RE pumps at pressures up to 4 bar and 7 bar are advised to fit a non-return valve between the pump and the discharge pipework to avoid the sudden release of pressurised fluid in the unlikely event of element failure.

9.2 Do's and do not's

Do not build a pump into a tight location without adequate airflow around the pump.

Do ensure that when the 520N watertight module is fitted the seals are intact and properly located.

Do ensure that the holes for cable glands are properly sealed to maintain the IP66 / NEMA 4X rating.

Do not strap the control and mains power cables together.

Do avoid tight bends in PROFIBUS signal cable.

Do keep delivery and suction tubes as short and direct as possible - though ideally not shorter than 1m - and follow the straightest route. Use bends of large radius: at least four times the tubing diameter. Ensure that connecting pipework and fittings are suitably rated to handle the predicted pipeline pressure. Avoid pipe reducers and lengths of smaller bore tubing than the pumphead section, particularly in pipelines on the suction side. Any valves in the pipeline (not usually needed with a self-priming peristaltic pump) must not restrict the flow. Any valves in the flow line must be open when the pump is running.

Do use suction and delivery pipes equal to or larger than the bore of the tube in the pumphead. When pumping viscous fluids use pipe runs with a bore several times larger than the pump tube.

Do ensure that on longer tube runs at least 1m of smooth bore flexible tubing is connected to the inlet and discharge port of the pumphead to help to minimise impulse losses and pulsation in the pipeline. This is especially important with viscous fluids and when connecting to rigid pipework.

Do site the pump at or just below the level of the fluid to be pumped if possible. This will ensure flooded suction and maximum pumping efficiency.

Do keep the pumphead track and all moving parts clean and free from contamination and debris.

Do run at slow speed when pumping viscous fluids. When using the 520R pumphead, a 6.4mm or 4.8mm bore tube with a 2.4mm wall will give best results. Tube smaller than this will generate a high friction loss, so reducing the flow. Tube with a larger bore may not have sufficient strength to reconstitute fully. Flooded suction will enhance pumping performance in all cases, particularly for materials of a viscous nature.

Do recalibrate after changing pump tubes, fluid, or any connecting pipework. It is also recommended that the pump is recalibrated periodically to maintain accuracy.

IP66 / NEMA 4X models may be hosed down, but should not be immersed. Protect from prolonged UV exposure.

When using Marprene or Bioprene continuous tubing, **do** re-tension the tube after the first 30 minutes of running.

Tube selection: The chemical compatibility lists published in Watson-Marlow publications are guides. If in doubt about the compatibility of a tube material and the duty fluid, request a Watson-Marlow tube sample card for immersion trials.

BpN, Bp

10 Connecting this product to a power supply



The voltage selector is mounted in the switchplate at the rear of the pump, protected from water by the 520N module. The module must be removed to allow access to the switchplate. See 22.1 *520N module removal and replacement*. Set the voltage selector to 115V for 100-120V 50/60Hz supplies or 230V for 200-240V 50/60Hz supplies. Always check the voltage selector switch before connecting the mains supply.

Make suitable connection to an earthed single-phase mains electricity supply.

BpN



The voltage selector switch is not visible while the 520N module is in place. Do not switch the pump on unless you have checked that it is set to suit your power supply by removing the module and inspecting the switch, and then refitting the module. See 22.1 *520N module removal and replacement*.

BpN, Bp



We recommend using commercially available supply voltage surge suppression where there is excessive electrical noise.

Power cable: The pump is supplied fitted with a cable gland and approximately 2.8m of power cable. Recommended cable: H05RN-F3G0.75; SJTW 105C 3-18AWG; max OD 8mm (5/16in).

This drawing shows the cable connections from below with the interface card cover removed.

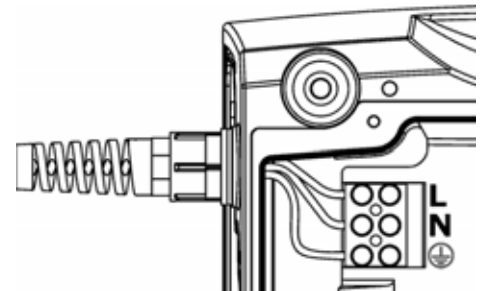

BpN

Power cables of NEMA 4X specification pumps are fitted with a standard US mains power plug. IP66 specification pumps are supplied with no plug. The colour code for the power cable is: brown - live; blue - neutral; green and yellow - earth.

BpN, Bp

If the mains power cable is inappropriate for your installation, it can be changed. This operation can be carried out with the 520N module in place, or after it has been removed, as shown here for clarity.

- Ensure that the pump is isolated from the mains power.



- Remove the six screws from the interface card cover underneath the pump. Lift off the interface card cover. You may find it convenient to remove the cover completely; if so, remove the cover earth lead.
- Undo the terminal block connectors. Remove the restraining clip by sliding its jaws sideways in opposite directions.
- Loosen the cable gland using a 19mm wrench and remove the gland and the cable.
- Thread a replacement cable through the three parts of the gland, the pump case and the restraining clip. Connect the new cable to the block connectors, following the drawing above.
- Tighten the restraining clip, and the gland to 2.5Nm. Check that the card cover earth link is secure. Replace the card cover, checking that the earth wire is not pinched beneath the cover lip. Take care that the sealing strip is properly seated to ensure a seal.



Input line fusing: type T2,5A H 250V 20mm time-delayed fuse, located in a fuseholder in the centre of the switchplate at the rear of the pump.

Power interruption: This pump has an auto-restart feature which, when active, will restore the pump to the operating state it was in when power was lost. See 18.6 *Auto-restart*.

Stop / start power cycles: Do not power up/power down for more than 100 starts per hour, whether manually or by means of the auto-restart facility. A minimum interval of 3 seconds is required between power cycles. We recommend remote control where a high frequency of power cycles is required.

11 Start-up check list

Note: See also 28 *505L tube loading* and 35.2 *520R and 520R2 tube loading*.

- Ensure that proper connections are achieved between the pump tube and suction and discharge piping.
- Ensure proper connection has been made to a suitable power supply.
- Ensure that the recommendations in the section on 9 *Good pump installation practice* are followed.

12 Switching the pump on for the first time

Note: This manual uses **bold** type to highlight the active option in menu screens: “**English**” in the first screen represented here. The active option appears on the pump display in **inverse** text.

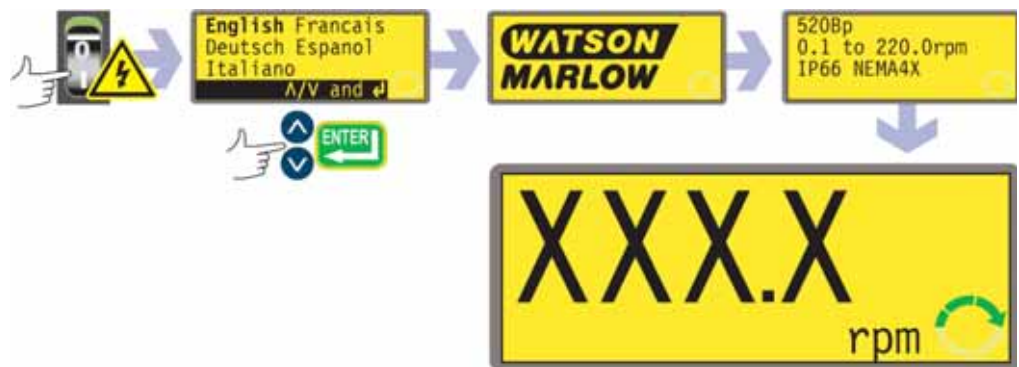

- Switch on the power supply at the rear of the pump. The pump runs a power-on test to confirm proper functioning of the memory and hardware. If a fault is found, an error message is displayed. See 24.1 *Error codes*.
- The pump displays a language menu. Use the **UP** and **DOWN** keys to select your language. Press the **ENTER** key to confirm your choice.
The information which follows assumes that your choice was English. When the language is chosen this menu will not appear again and all menus will appear in the language you chose. (Language can be reset as described later. See 18.10 *Language*.)
- The pump displays the Watson-Marlow start-up screen for four seconds, followed by the pump model identity screen for four seconds, and then the manual mode main screen.
- The rotation symbol on the display indicates clockwise rotation. The speed of rotation is the pump’s maximum. Other initial start-up operational parameters are listed in the table below.

First-time start-up defaults			
Language	Not set	Auto-restart	Off
Speed	Maximum	Pump status	Stopped
Direction	Clockwise	Beeper	On
Pumphead	520R	Manual screen	rpm
Tube size	9.6mm	Security code	Not set
Calibration	from head and tube table	Pump address	126
Backlight	On	Scrolling increment	0.1 rpm
Keypad lock	Off	PROFIBUS	Enabled

The pump is now ready to operate according to the defaults listed above.

All operating parameters may be changed by means of key-presses. See 14 *Manual operation*.

13 Switching the pump on in subsequent power cycles (if not in auto-restart mode)

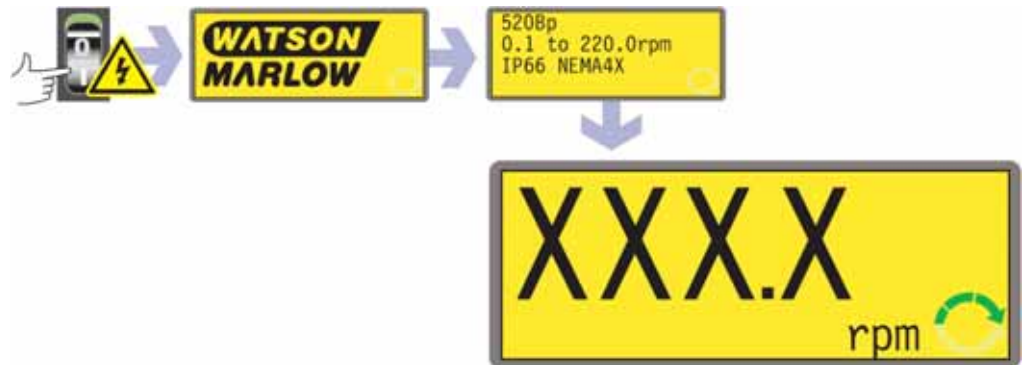

- Switch on the power supply at the rear of the pump. The pump runs a power-on test to confirm proper functioning of the memory and hardware. If a fault is found, an error message is displayed. See 24.1 *Error codes*.
- The pump displays the Watson-Marlow start-up screen for four seconds followed by the pump model identity screen for four seconds, and then the manual mode main screen.
- **Note:** If ANY key is pressed during the display of any of the preliminary screens, the display jumps to the next screen. Quickly pressing any two keys or any key twice immediately after switch-on causes the display to jump to the manual mode main screen. Once in the manual mode main screen, keys assume their normal functions - see 14.1 *Keypad functions in manual mode* below. A subsequent press on **START** causes the pump to operate.
- Start-up defaults are those in place when the pump was switched off last. Check that the pump is set to operate as you require it.

The pump is now ready to operate.

All operating parameters may be changed by means of key-presses. See 14 *Manual operation*.

14 Manual operation

Note: While the pump is under manual control, it responds to interrogation by the PROFIBUS master if it is connected to a PROFIBUS network (see 22.2.1 *PROFIBUS wiring*) and PROFIBUS is enabled (see 18.2 *PROFIBUS enable*).

14.1 Keypad functions in manual mode

All settings and functions of the pump in manual mode are set and controlled by means of key-presses. Immediately after the start-up display sequence detailed above, the manual mode main screen will be displayed. The currently selected rotation direction is indicated on the display by a clockwise or counter-clockwise segmented arrow. If an exclamation mark (!) shows, it indicates that Auto-restart is on (see 18.6 *Auto-restart*). If a padlock icon (🔒) shows, it indicates that Keypad lock is on (see 14.2 *Keypad lock*).

Note: A number of the controls listed below are shortcuts to commands which are also available through the Main menu. See 15 *Main menu*.

A brief single press on each key triggers a beep sound (if enabled - see 14.3 *Keypad beep*) and causes the pump to function as follows:

- **START:** starts the pump at the speed and in the direction shown on the display. The rotation symbol will become animated to confirm that the pump is operating. We recommend that the speed is reduced to a minimum (0.1 rpm) before starting the pump. If the pump is running when **START** is pressed, it causes the information shown on the manual mode main screen to cycle from revolutions per minute, to flow rate in a choice of units (via a warning screen if flow rate has not been



calibrated and if this is the first cycle since power-up) to rpm, flow rate and Run time. An example is shown here. (See **START**, above. See 17 *Calibrate*. See 18.5 *Run time*.) This cycle operates when the pump is stopped and when it is running. The default can be altered from within the Setup menu. See 18.3 *Display*.

- **MAX**: while pressed, **MAX** operates the pump at the maximum allowed speed and in the direction shown on the display. When released, the pump returns to its previous status.

Note: Priming can be achieved by pressing the **MAX** key until fluid flows through the pump and reaches the point of discharge, and then releasing the **MAX** key.



- **AUTO/MAN**: toggle the pump into PROFIBUS network control (if PROFIBUS Setup procedures have been followed: see 18 *Setup*) and displays the pump's address, direction of rotation, the speed at which it will run if it receives a PROFIBUS telegram to start, and its calibrated flow rate.
- **STOP**: has no effect if the pump is not running. If the pump is running, pressing **STOP** stops the pump. The display will continue to show the previous speed and direction. The pump will return to this speed and direction when the **START** key is pressed again.
- **UP**: increases the speed shown on the display in minimum steps of 0.1 rpm (unless the speed displayed is already the maximum allowed speed). If the pump is then started by pressing the **START** key, it will operate at the new speed. If the pump is running when **UP** is pressed, the change takes effect immediately.

Note: After a speed change, a screen showing the new rpm figure **and** the new flow rate is displayed for four seconds before returning the user to the previously set manual mode main screen: rpm **or** flow rate.
- **DOWN**: decreases the speed shown on the display in minimum steps of 0.1 rpm. If the pump is then started by pressing the **START** key, it operates at the new speed. The minimum speed possible is 0.1 rpm. If the pump is running when **DOWN** is pressed, the change takes effect immediately.

Note: After a speed change, a screen showing the new rpm figure **and** the new flow rate is displayed for four seconds before returning the user to the previously set manual mode main screen: rpm **or** flow rate.

Note: You can reduce the pump speed from 0.1 rpm to 0 rpm by a further press on the **DOWN** key. The pump is still in the running state and the rotation symbol will continue to move. Press the **UP** key to return the pump to the minimum speed.
- **DIRECTION**: toggle the direction of rotation shown on the display. If the pump is then started by pressing the **START** key, it rotates in the new direction. If the pump is running when **DIRECTION** is pressed, the change takes effect immediately.

- **ENTER**: cycles the information shown on the manual mode main screen from revolutions per minute, to flow rate in a choice of units (via a warning screen if flow rate has not been calibrated) to rpm, flow rate and Run time. (See **START**, above. See 17 *Calibrate*. See 18.5 *Run time*.) This cycle operates when the pump is stopped and when it is running. The default can be altered from within the Setup menu. See 18.3 *Display*.
- **MENU**: causes the main menu to be displayed, from which all aspects of pump setup can be controlled. See 15 *Main menu*.

Keypress combinations cause the pump to function as follows:

- **UP** and **DIRECTION** on power-up: toggle the keypad beep on and off.
- **START** on power-up: switches on the Auto-restart facility. See 18.6 *Auto-restart*.
- **STOP** on power-up: switches off the Auto-restart facility. See 18.6 *Auto-restart*.
- **STOP** and **UP** while the pump is stopped: turns the display backlight on.
- **STOP** and **DOWN** while the pump is stopped: turns the display backlight off.
- **MAX** and **UP**: sets the pump to maximum allowed speed.
- **MAX** and **DOWN**: sets the pump to minimum speed.
- **DIRECTION** and **DOWN**: interrupts the display to show the pump's ROM version for four seconds.
- **START** pressed and held for two seconds: toggle the keypad lock on and off. Only the **START** and **STOP** keys are active when keypad lock is on. The padlock icon is displayed.
- **STOP** pressed and held for two seconds: toggle the keypad lock on and off. Only the **START** and **STOP** keys are active when keypad lock is on. The padlock icon is displayed.
- **STOP STOP** within half a second: shortcut entry to MemoDose; when in MemoDose, shortcut return to manual mode main screen. See 20 *MemoDose*.

Note: The maximum allowed speed of the drive defaults to 220 rpm. It is possible to set this limit at any speed up to this value. See 18.7 *Set maximum speed*.

14.2 Keypad lock

The keypad can be locked to prevent changes to pump speed or other settings, and make it possible only to start or stop the pump. The padlock symbol shows on the display.

- While the pump is running, hold down the **START** key for two seconds. The padlock symbol shows and only the **START** and **STOP** keys function.
- The keypad may also be locked while the pump is stopped. Hold down the **STOP** key for two seconds. The padlock symbol shows and only the **START** and **STOP** keys function.
- To unlock the keypad while the pump is running hold down the **START** key for two seconds. The padlock symbol is removed. If the pump is stopped hold down the **STOP** key until the padlock symbol is removed.

14.3 Keypad beep

The pump keypad can operate silently or indicate a positive key-press with a beep sound.

- To toggle the sound on and off, stop the pump. Turn off the mains power switch at the rear of the pump.
- Depress the **UP** and **DIRECTION** keys while switching on the mains power switch at the rear of the pump.

15 Main menu

15.1 Keypad functions in menu screens

In addition to their functions in other operations, the following keys have specific actions in menu screens:

- **STOP:** In general, **STOP** functions as a “go back” key, taking the user up one menu level without making a change.
- **UP:** The **UP** key is used in menu item selection: it moves a highlight up the menu. When a numerical entry screen is displayed, pressing **UP** increases the number displayed.
- **DOWN:** The **DOWN** key is used in menu item selection: it moves a highlight down a menu. When a numerical entry screen is displayed, pressing **DOWN** decreases the number displayed.
- **ENTER:** The **ENTER** key functions in a similar way to the “enter” key of a personal computer: it confirms key-presses made immediately before. In menu item selection, it triggers the action or display selected from a menu using the **UP** and **DOWN** keys.



Note: Confirmation screens are displayed for 4 seconds. While they are displayed, a single press on any key removes them.

15.2 Main menu entry

The **MENU** key displays the main menu. It operates at any point in the pump's activity except where error screens are displayed, or screens where **UP** and **DOWN** keys are used to enter values.



The main menu offers five options: **Calibrate**, **Setup**, **Pin out details**, **MemoDose** and **Exit**. Use the **UP** and **DOWN** keys to make a choice. Press the **ENTER** key to confirm your decision.

Calibrate

Calibrate allows the user to calibrate the pump with default figures for a range of pumpheads and tubes, as well as to refine the flow rate figures with a calibration dose facility.

Setup

Setup allows the user to set the pump's operating parameters under 14 headings: **Pump address**, **PROFIBUS enable**, **Display**, **Flow units**, **Run time**, **Auto-restart**, **Set max speed**, **Backlight**, **ROM**, **Language**, **Defaults**, **Beep**, **Security code** and **Exit**.

Pin out details

Bp

Selecting **Pin out details** causes the pump to display an information screen and then its preset pin and voltage details under seven headings: PROFIBUS I/O, Leak input, Supply, 0 volts, Earth, Others and Exit.

BpN

Pin out information is not relevant to the 520BpN IP66/NEMA 4X pump. Selecting **Pin out details** causes the pump to display a warning screen and redisplay the main menu.

BpN, Bp

MemoDose

The **MemoDose** facility is used to remember the number of revolutions needed to dispense a set volume of fluid, and cause the pump to dispense that volume repeatedly.

Exit

If **Exit** is selected, the pump returns to its last manual state with the pump stopped.

16 PIN-secure process protection

The 520BpN and 520Bp feature PIN-secure process protection. This allows the pump to be configured to suit the application, and for the setup to be protected by two levels of PIN code. See 18.13 *Security code*.

Menu option or keypress	With Main code set	With User code set	Code set and keypad locked
Menu	Available	Available	Not available
Calibrate	Available	Available	Not available
Accept	Available	Available	Not available
Change	Main PIN needed	Main PIN or User PIN needed	Not available
Setup	Main PIN needed	Main PIN needed; User PIN invalid	Not available
MemoDose	Available	Available	Available*
Pin out details	Available	Available	Not available
Max	Available	Available	Not available
Dir	Main PIN needed	Main PIN or User PIN needed	Not available
Auto / Man	Available	Available	Not available
Up	Available	Available	Not available
Down	Available	Available	Not available
Max and Up	Available	Available	Not available
Max and Down	Available	Available	Not available
Start	Available	Available	Available
Stop	Available	Available	Available
Enter	Available	Available	Not available
Keypad lock	Main PIN needed	Main PIN or User PIN needed	Main PIN or User PIN needed
Auto-restart	Available	Available	Available

* When the keypad is locked, MemoDose is available via its access shortcut: press **STOP** twice; it is not available through the menu structure.

The main code allows changes to **Calibrate**, **Setup**, **Direction** and **Keypad lock**.

The secondary (User) code permits **Calibrate**, **Direction** change and **Keypad lock** but bars **Setup** change.

If either code is used in conjunction with Keypad lock, all keys are disabled except **STOP** and **START**.

To activate and set a security code, see 18.13 *Security code*.

If the main code is lost or forgotten: The Setup main security code can be bypassed by entering a special key sequence; all codes can then be cancelled and reset. Contact Watson-Marlow or your distributor for details.

17 Calibrate

The pump can display flow rate in a choice of units as well as speed in revolutions per minute. It must first be calibrated.

Pump calibration can be limited to users who correctly enter a three-digit security code. If a security code has been set, selecting **Change** from the calibration details screen and confirming with the **ENTER** key causes the pump to display the Security code entry sequence. See 16 *Pin-secure process protection*. If no security code has been set, the pump displays the first screen of the calibration sequence.

To dispense the correct amount of fluid the pump must know which pumphead is fitted and the tube size in the pumphead. The pump is pre-programmed with default flow rate figures for a range of pumpheads and tubes. You may also measure the flow from the pump and enter this value for the most accurate calibration.

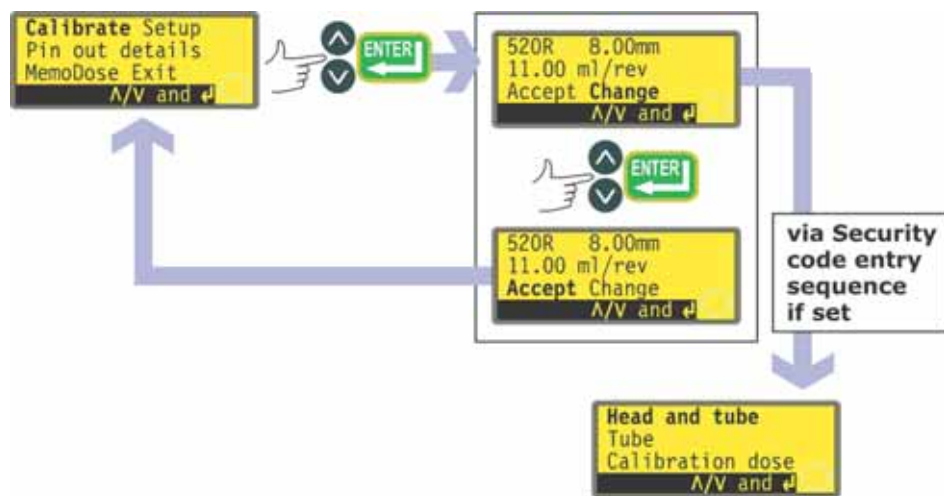

- Use the **UP** and **DOWN** keys to highlight **Calibrate** in the main menu. Press **ENTER** to confirm.
- The pump displays its current settings: pumphead, tube size and flow rate; the default for each standard pumphead is the largest tube the pumphead can take. Example information is shown here.
- Use the **UP** and **DOWN** keys to highlight **Accept** or **Change**. Press **ENTER** to confirm.
- If **Accept** is selected, the default or previously set flow rate data for that pumphead and tube size are used in flow rate calculations. The pump redisplay the main menu.
- If **Change** is selected with a security code in place, the pump starts its security code entry sequence. See 16 *Pin-secure process protection*. When the correct code is entered, the pump offers three options: **Head and tube**; **Tube**; and **Calibration dose**. If **Change** is selected with no security code in place, the three options are displayed immediately.
- Use the **UP** and **DOWN** keys to make a selection. Press **ENTER** to confirm.

Head and tube



- If **Head and tube** is selected, the pump displays a list of standard pumpheads that can be fitted to the pump. It occupies two screens. Use the **UP** and **DOWN** keys to move the highlight down the list. When the last item on the first screen is highlighted, a further press on the **DOWN** key causes the pump to display the second screen with its first item highlighted.
- Use the **UP** and **DOWN** keys to make a selection. Press **ENTER** to confirm. An example is shown here.
- The pump displays tube sizes, as below.

Tube



- If **Tube** is selected or a pumphead choice has just been made, the pump displays a list of standard tube sizes that can be used in the pumphead previously identified.
- Use the **UP** and **DOWN** keys to make a selection. Press **ENTER** to confirm.

Calibration dose

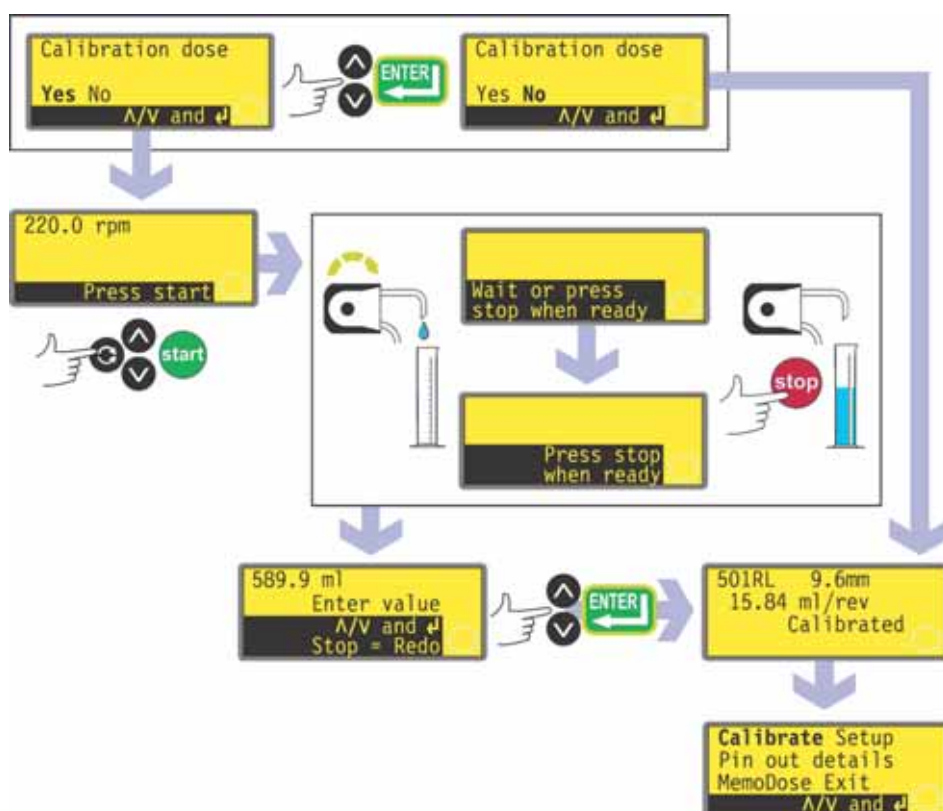

- The pump offers to run a calibration dose. Use the **UP** and **DOWN** keys to choose **Yes** or **No**. Press **ENTER** to confirm. Examples are shown here.
- If **No** is selected after a tube selection has been made (see *Tube* above), the pump briefly displays a confirmation screen showing current head, tube and flow settings, and redisplay the main menu.
- If **Calibration dose** is selected or if **Yes** is selected after a tube selection has been made (see *Tube* above), the pump displays the speed and direction at which it was last running in manual mode or to which it has just been set and invites the user to press **START**.
- **Note:** it is possible at this point to change the direction of rotation using the **DIRECTION** key, and the change the speed of rotation using the **UP** and **DOWN** keys, up to the pump's maximum speed or any (lower) maximum available speed which has previously been set. See 18.7 *Set maximum speed*.
- Put a measuring container at the pump outlet. Press **START**. The pump runs for 4 minutes, displaying an information screen for 15 seconds and a further information screen for the rest of the 4 minutes. You may stop the calibration dose at any time with the **STOP** key - but allow the pump to run as long as possible to obtain the most accurate calibration. A minimum of 15 seconds is recommended.

- Measure the quantity of fluid dispensed. The pump displays its calculated dose, based on previous calibration data. Use the **UP** and **DOWN** keys to adjust this reading to match the measured volume. Press **ENTER**. The pump displays the new head, tube and flow settings, and redisplayes the main menu. Example figures are shown here.



Note: If the pump has been set to display flow rate in units of mass (see 18.4 *Flow units*), as in this example, the pump displays a screen allowing you to confirm the specific gravity of the duty fluid immediately before the final press on **ENTER**.

Note: Always recalibrate after changing pump tubes, fluid, or any connecting pipework. It is also recommended that the pump is recalibrated periodically to maintain accuracy.

Note: If the pump power is cycled while flow rate is displayed, calibration is lost and a warning is displayed.

18 Setup

Entry to the Setup menu can be limited to users who correctly enter a three-digit security code. If a security code has been set, selecting **Setup** and confirming with the **ENTER** key causes the pump to display the Security code entry sequence. See 16 *Pin-secure process protection*. If no security code has been set, the pump displays the first of four screens containing the Setup menu.

The Setup menu

The Setup menu occupies four screens. The first two are shown here.

To move from one screen to subsequent screens, repeatedly press **DOWN**. Each item is highlighted in turn until the last item on the screen is highlighted.

A further press on the **DOWN** key displays the next screen of the menu, with the first item highlighted.

Follow the reverse procedure using the **UP** key to move to an item on a previous screen of the menu.

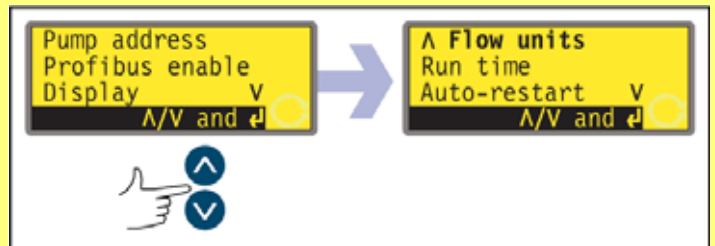

Make a selection using the **UP** or **DOWN** keys and press **ENTER** to confirm your choice.

18.1 Pump address

The 520BpN pump can be individually controlled under PROFIBUS as one of up to 125 devices. Its default network address is 126. It can be given another address.

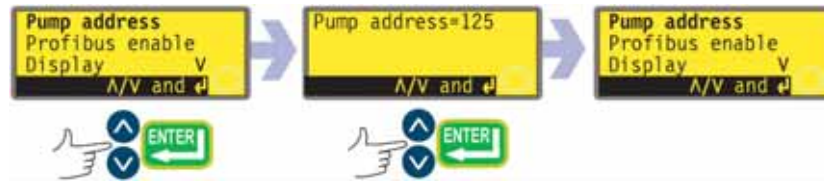

- In the first screen of the Setup menu select **Pump address** using the **UP** and **DOWN** keys. Press **ENTER** to confirm your choice.
- The pump displays a screen allowing you to change the pump's address. Use the **UP** and **DOWN** keys to change the number in the display to an integer from 1 to 125 and press **ENTER** to confirm your decision. An example is shown here.
- The pump displays the first screen of the Setup menu.
- Switch off power to the pump, wait for 3 seconds and switch on. The pump address is now updated.

Note: While the pump still carries its default address—126—its address can be changed as described here, or changed remotely from the PROFIBUS master. If its address is no longer 126, any further address change must be made as described here.

18.2 PROFIBUS enable

The 520BpN pump's default state is PROFIBUS-enabled, allowing it to be connected to a PROFIBUS network. See 23 *Switching to PROFIBUS network control*. It can be PROFIBUS-disabled and re-enabled.

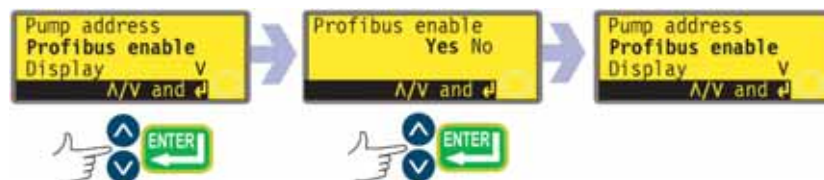

- In the first screen of the Setup menu select **PROFIBUS enable** using the **UP** and **DOWN** keys. Press **ENTER** to confirm your choice.
- The pump displays a screen allowing the user to enable or disable PROFIBUS. Use the **UP** and **DOWN** keys to choose **Yes** or **No** and press **ENTER** to confirm your choice.
- The pump displays the first screen of the Setup menu.

18.3 Display

The pump can display three default screens in manual mode: revolutions per minute, flow rate in a choice of units, or both.

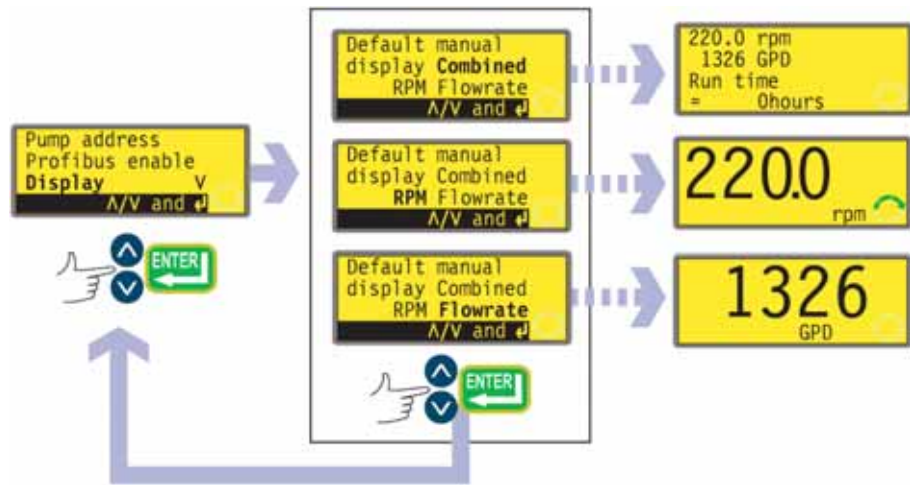

- In the first screen of the Setup menu select **Display** using the **UP** and **DOWN** keys. Press **ENTER** to confirm your choice.
- The pump displays a screen allowing you to choose the format of the manual mode main screen. Use the **UP** and **DOWN** keys to choose and press **ENTER** to confirm your decision.
- If you choose **flow rate** and you have not calibrated the pump since switching it on, a warning screen is displayed for 4 seconds. The warning does not appear if the display screen formats are cycled again, unless the pump has been switched off in the mean time.
- The pump redisplay the first screen of the Setup menu.
- When the pump next runs, the manual mode main screen will display pump activity in rpm, flow rate (in the units you chose - see 18.4 *Flow units*) or both, according to your choice, plus a run time figure. Examples are shown here.

Alternatively ...

- In the manual mode main screen, repeatedly press **ENTER** to cycle the display between rpm, flow rate (in the units you chose - see 18.4 *Flow units*) or combined, according to your choice. This cycle operates if the pump is running and if it is stopped. While the pump is running, you can cycle the display in the same way by repeatedly pressing **START**. In both cases, if you have not calibrated the pump since switching it on, a warning screen is displayed for 4 seconds before the flow rate screen appears. The warning does not appear if the display screen formats are cycled again, unless the pump has been switched off in the mean time.
- The pump redisplay the first screen of the Setup menu.

18.4 Flow units

The pump can display its flow rate in metric (SI) or US (imperial) units of volume or mass.

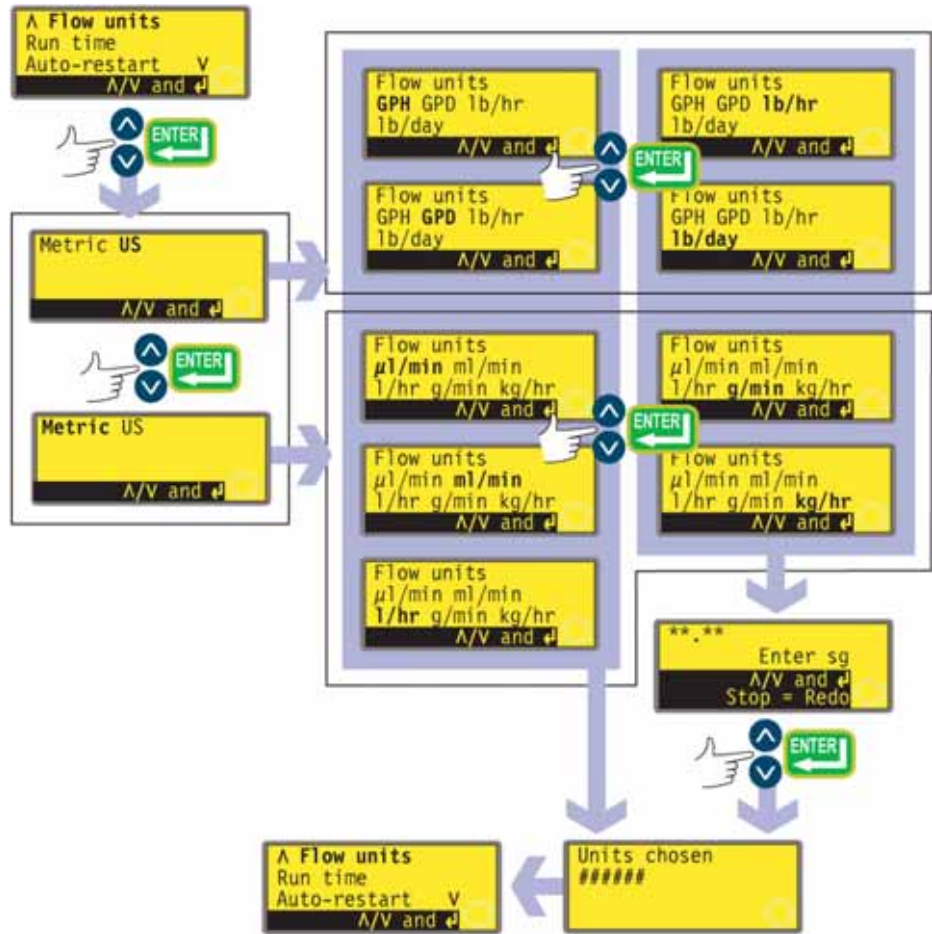

- In the second screen of the Setup menu select **Flow units** using the **UP** and **DOWN** keys. Press **ENTER** to confirm your choice.
- The pump displays a screen offering Metric or US. Use the **UP** and **DOWN** keys to choose and press **ENTER** to confirm your decision.
- If you chose Metric, the pump offers a choice of units: $\mu\text{l}/\text{min}$, ml/min, l/hr, g/min or kg/hr. Use the **UP** and **DOWN** keys to choose and press **ENTER** to confirm your decision.
- If you chose US, the pump offers a choice of units: US Gallons/hr, US Gallons/day, lb/hr or lb/day. Use the **UP** and **DOWN** keys to choose and press **ENTER** to confirm your decision.

- If you chose a volumetric flow rate from either screen, a confirmation screen appears briefly and the pump displays the second screen of the Setup menu.
- If you chose a mass flow rate from either screen, the pump asks for the specific gravity of the fluid to be pumped. Use the **UP** and **DOWN** keys to enter a value between 0.01 and 15.00. Press **ENTER** to confirm your decision. Press **STOP** if you decide to make a different choice of units.
- A confirmation screen appears briefly and the pump displays the second screen of the Setup menu.

18.5 Run time

The pump cumulatively records how many complete hours its motor runs. The figure can be displayed or reset to zero.

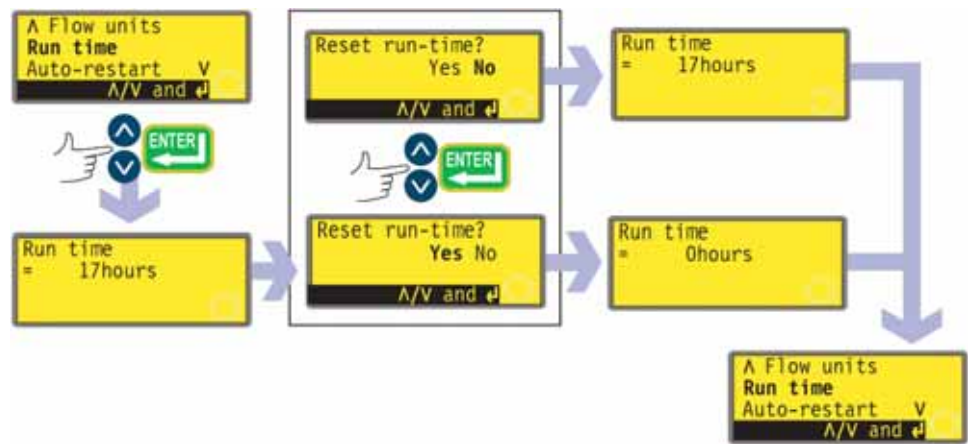

- In the second screen of the Setup menu select **Run time** using the **UP** and **DOWN** keys. Press **ENTER** to confirm your choice.
- The pump briefly displays the total hours its motor has operated since the last time the counter was reset to zero hours, followed by an opportunity to reset the counter to zero hours. An example is shown here. Use the **UP** and **DOWN** keys to choose **Yes** or **No** and press **ENTER** to confirm your decision.
- The total hours screen is briefly displayed with its total reset to zero hours, or unchanged, as appropriate. The pump displays the second screen of the Setup menu.

Note: Run time is displayed on the Combined display. See 18.3 *Display*. Run time does not zero when factory default is selected.

18.6 Auto-restart

This pump offers an auto-restart feature. If active on power loss, it restores the pump when power returns to the operating state it was in when power was lost. It does not operate when powering down in the middle of a dose: when the pump is restarted, it will await a press on the **START** key to begin the interrupted dose again. Auto-restart is retained while the pump is switched off. When the pump starts running, look for the ! symbol on the display. This ! symbol indicates that the pump is set for auto-restart.

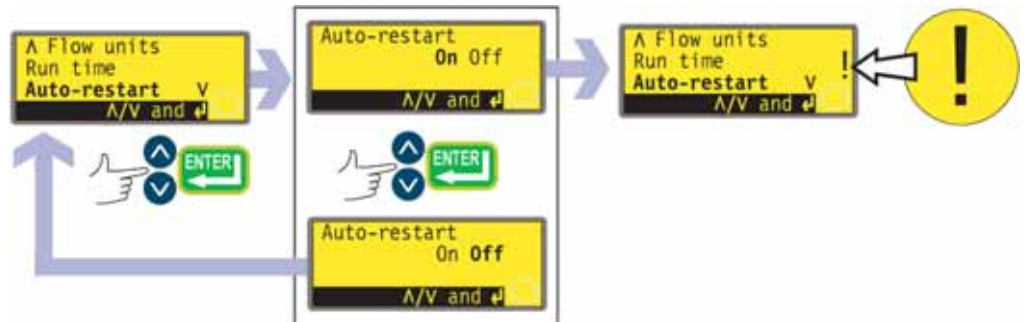

- In the second screen of the Setup menu select **Auto-restart** using the **UP** and **DOWN** keys. Press **ENTER** to confirm your choice.
- The pump displays a screen allowing the user to activate auto-restart. Use the **UP** and **DOWN** keys to choose **On** or **Off** and press **ENTER** to confirm the decision.
- If **Off** is chosen, the pump returns the user to the second screen of the Setup menu. The auto-restart facility will not operate.
- If **On** is chosen, the pump returns the user to the second screen of the Setup menu, where an exclamation mark (!) is now visible. This mark confirms that the auto-restart feature is in place and will operate the next time power is lost and restored.

Alternatively ...

- Stop the pump. Turn off the mains power switch at the rear of the pump.
- Hold down the **START** key and turn on the mains power switch. The ! symbol shows on the display.
- Start the pump. If the mains supply is interrupted the pump will automatically restart when the mains power returns.
- To remove auto-restart switch off the mains power at the rear of the pump. Hold down the **STOP** key and turn the mains power switch on. The ! symbol does not appear.



Do not use auto-restart for more than 100 starts per hour. A minimum interval of 3 seconds is required between power cycles. We recommend remote control where a high number of starts is required.

18.7 Set maximum speed

The pump offers a maximum speed of 220 revolutions per minute. This limit can be reduced for operational purposes.



- In the third screen of the Setup menu select **Set max speed** using the **UP** and **DOWN** keys. Press **ENTER** to confirm your choice.
- The pump displays a screen allowing the user to set the maximum speed of the pump equal to or lower than the maximum available. Use the **UP** and **DOWN** keys to set the maximum allowed speed and press **ENTER** to confirm the figure.
- The pump returns the user to the third screen of the Setup menu.
- Altering the maximum speed automatically re-scales the analogue speed control response.

Note: The maximum speed available depends on the pumphead selected during calibration.

18.8 Backlight

The pump's display can be illuminated or not according to choice.

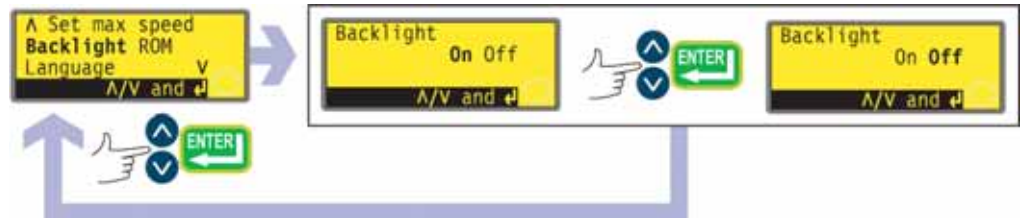

- In the third screen of the Setup menu select **Backlight** using the **UP** and **DOWN** keys. Press **ENTER** to confirm your choice.
- The pump displays a screen allowing the user to switch the display backlight on or off. Use the **UP** and **DOWN** keys to choose **On** or **Off** and press **ENTER** to confirm the decision.
- The pump returns the user to the third screen of the Setup menu. The display is now illuminated or not according to the user's decision.

Alternatively ...

- To turn the backlight off: press **STOP** and **DOWN** together.
- To turn the backlight on: press **STOP** and **UP** together.

18.9 ROM

The pump can display its software version, model number and pump speed.



- In the third screen of the Setup menu select **ROM** using the **UP** and **DOWN** keys. Press **ENTER** to confirm your choice.
- The pump displays the software version, model number and pump speed for four seconds, then returns the user to the third screen of the Setup menu. It also displays a checksum: CHK 123, for example. This may be required if reporting pump performance to the Watson-Marlow service department.

Alternatively ...

- Press **DIRECTION** and **DOWN** together to interrupt the display and show the pump's ROM version for four seconds.

18.10 Language

The pump can be set to operate in several languages.



- In the third screen of the Setup menu select **Language** using the **UP** and **DOWN** keys. Press **ENTER** to confirm your choice.
- In the next screen, choose a language using the **UP** and **DOWN** keys. Press **ENTER** to confirm your choice. The pump redisplay the third Setup screen in your chosen language. All screens will subsequently appear in your chosen language.

18.11 Defaults

All the pump's user-set data can be reset to factory defaults.



- In the fourth screen of the Setup menu select **Defaults** using the **UP** and **DOWN** keys. Press **ENTER** to confirm your choice.
- A warning is displayed for four seconds, and the pump asks the user to confirm that factory defaults are to be reset. Use the **UP** and **DOWN** keys to choose **Yes** if you wish the pump to reset all user-set data back to factory defaults (see 12 *Switching the pump on for the first time*); or **No** if you do not wish to do this. Press **ENTER** to confirm your decision. If **Yes** was chosen, the pump will reset its factory defaults and redisplay the fourth Setup screen. If **No** was chosen, the pump will make no changes to its setup and redisplay the fourth Setup screen.

18.12 Beep

The pump keypad can operate silently or indicate a positive key-press with a beep sound.



- In the fourth screen of the Setup menu select **Beep** using the **UP** and **DOWN** keys. Press **ENTER** to confirm your choice.
- In the next screen, use the **UP** and **DOWN** keys to choose **On** or **Off**. Press **ENTER** to confirm your decision. The pump redisplay the fourth Setup screen.

Alternatively ...

To toggle the sound on and off, stop the pump. Turn off the mains power switch at the rear of the pump.

Depress the **UP** and **DIRECTION** keys while switching on the mains power switch at the rear of the pump.

18.13 Security code

Access to the pump's Setup menu, direction control and keypad lock can be restricted to those who correctly enter a three-digit security code: the main code. A secondary user code can be set, which permits PIN access to direction and keypad lock, but blocks access to Setup. See 18 Setup, 14.1 Keypad functions in manual mode and 14.2 Keypad lock.

The code must first be set.

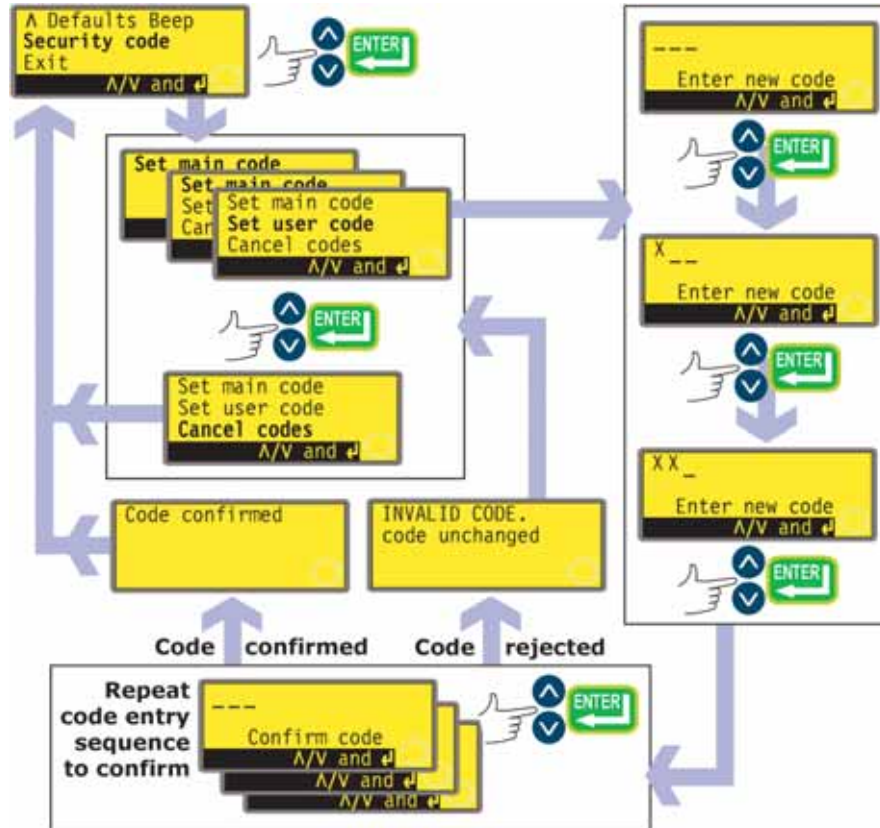

- In the fourth screen of the Setup menu select **Security code** using the **UP** and **DOWN** keys. Press **ENTER** to confirm.
- If no code has been set, a screen is displayed inviting the user to set a main code. Press **ENTER** to proceed (or **STOP** to return to the fourth screen of the Setup menu).
- If a main code has been set, a screen is displayed inviting the user to set a new main code, to set a user code (or a new user code if one has already been set), or to cancel all codes. Choose **Set main code**, **Set user code** or **Cancel codes** using the **UP** and **DOWN** keys. Press **ENTER** to confirm your choice.

- If you chose **Cancel codes**, any codes previously set are cancelled and access to the pump is not restricted.
- If you chose **Set main code** or **Set user code**, the pump displays a screen with three blank spaces for digits and the instruction "Enter new code". Use the **UP** and **DOWN** keys to enter three digits. Press **ENTER** to confirm each one. The pump displays a similar three-digit entry screen and the instruction "Confirm code".
- Repeat the digit-entry sequence.
- If the second three-digit code entered differs from the first, or if the digits chosen as a user code are the same as those already set as a main code, the pump briefly displays an error message and redisplay the set code options screen.
- If the codes tally and, for a user code, if there is no clash with a previously set main code, the pump briefly displays a confirmation message and redisplay the fourth Setup screen. Access to the Setup and Configuration menus, Dose, direction control and keypad lock is now protected by the new security code.
- If **STOP** is pressed during code entry, the pump returns the user to the fourth Setup screen. If **STOP** is pressed during code confirmation, the pump returns the user to the first digit-entry screen.

Note: A user code cannot be set unless a main code has previously been set. If you wish to cancel only a user code, you must use **Cancel codes** to cancel both user and main codes, then use **Set main code** to set a new main code.

Note: If a code has been set but forgotten, it is still possible to access the Setup screens to cancel the code or reset it to another three-digit number. Contact your supplier or Watson-Marlow Technical support for the bypass sequence.

18.14 Exit



- In the fourth screen of the Setup menu **Exit** is highlighted. Press **ENTER**.
- The user is returned to the main menu.

19 Pin out details

Bp

Pin out details

Selecting **Pin out details** from the main menu causes the pump to display an information screen and then its preset pin and voltage details under six headings: **PROFIBUS I/O, Leak input, Supply, 0 volts, Earth** and **Others**. No user input is available in this section; it displays information only.

In the main menu, select **Pin out details** using the **UP** or **DOWN** keys and press **ENTER** to confirm your choice.

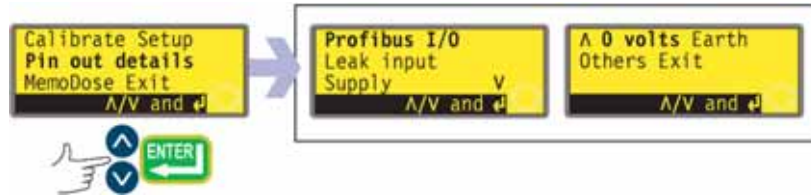

The Pin out details menu

The Pin out details menu occupies two screens. To move from one screen to the next, repeatedly press **DOWN**. Each item is highlighted in turn until the last item on the screen is highlighted. A further press on the **DOWN** key displays the next screen of the menu, with the first item highlighted.

Follow the reverse procedure using the **UP** key to move to an item on the first screen of the menu.

- Use the **UP** or **DOWN** keys to make a selection. Press **ENTER** to confirm.
- The screens available are all presented in a similar manner. For example, on selecting **Leak input**, the following screen is displayed:

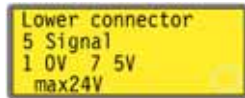

This indicates that the leak detector input signal must be applied to pin 5 of the lower D-connector at the rear of the pump, where 0 volts is available on pin 1 and 5 volts on pin 7. The maximum permitted voltage is 24 volts.

The information available on selecting **Supply** and **Others** is presented on two screens each. Pressing **DOWN** when the first screen of each is displayed causes the second screen to appear. **UP** performs a similar function.

Pressing **STOP** or **ENTER** in any Pin out information screen returns the user to the appropriate Pin out menu screen.

To leave the Pin out menu screens

Display the second screen of the Pin out menu. Select **Exit** using the **UP** or **DOWN** keys and press **ENTER** to confirm your choice.

Alternatively ...

Repeatedly press **STOP** to go back level by level until the main menu is displayed.

BpN

Pin out information is not relevant to the 520BpN IP66 / NEMA 4X pump. Selecting **Pin out details** causes the pump to display a warning screen and redisplay the main menu.

20 MemoDose

Each time the pump is started by pressing **START**, it records the number of pump-head revolutions which occur until **STOP** is pressed. The number of revolutions is proportional to the volume of fluid which has been dispensed: the dose. The MemoDose facility allows the user to repeat-dose a precise volume of fluid. To do so, a quantity of fluid must be dispensed as the master dose which the MemoDose facility can repeat exactly or proportionately.

To dispense a master dose

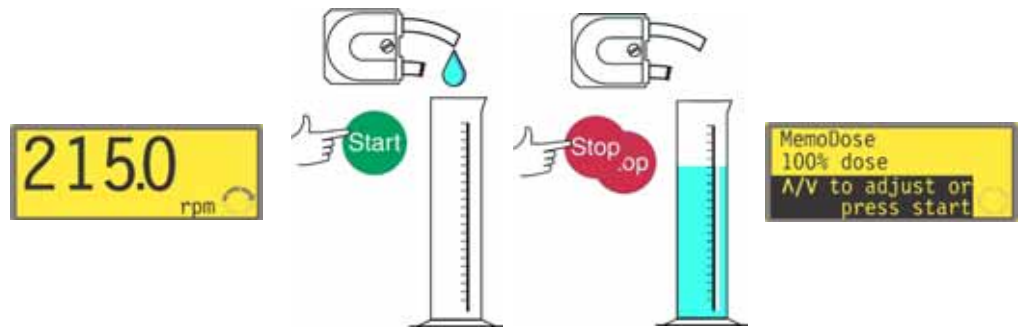

- In the manual mode main screen, set the appropriate pump speed and direction using the **UP** or **DOWN** keys and the **DIRECTION** key. An example is shown here. A slower speed may make it easier for the user to measure accurately - though it may not represent the duty condition.
- Place a suitable measuring vessel under the pump delivery tube.
- Press **START**. The pump runs and fluid is pumped into the vessel.
- When the required volume of fluid has been dispensed, it is necessary to stop the pump and display the MemoDose screen. This can be achieved in three ways.
 1. Press the **STOP** key twice within half a second. The pump stops and immediately displays the MemoDose screen.
OR...
 2. Press the **STOP** key once. The pump stops. (This may make it easier to ensure that the quantity of fluid that has been dispensed is sufficiently precise.) Then press the **STOP** key twice within half a second. The pump displays the MemoDose screen.
OR ...
 3. Press the **STOP** key. The pump stops. Press the **MENU** key. Use the **UP** or **DOWN** keys to select **MemoDose**. Press **ENTER** to confirm. The pump displays the MemoDose screen.

To repeat the dose

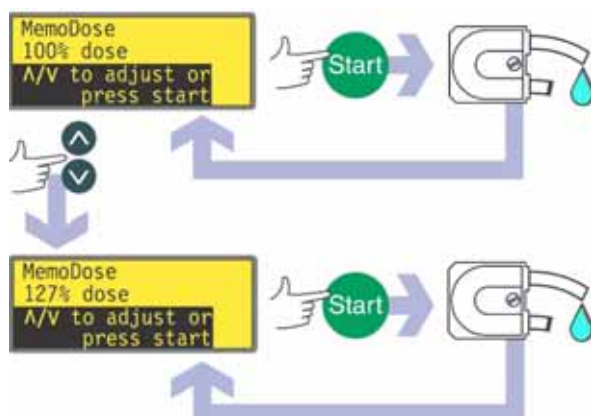

- The pump has recorded the number of pumphead revolutions required to dispense the master dose. If the volume of fluid in the measuring vessel is the volume required, press **START** to repeat the dose.
- If the volume of fluid in the measuring vessel differs from the volume required, the percentage may be adjusted within the limits 1% to 999% of the master dose. Use the **UP** or **DOWN** keys to alter the percentage. Press **START** to dispense the new dose.
- The display counts down as the dose proceeds and stops when the dose is complete.
- If **STOP** is pressed during dosing, the pump stops and returns the user to the MemoDose percentage screen.

Press the **STOP** key twice within half a second if you wish to exit MemoDose and return to manual operation.

20.1 Changing dosing speed

The user must exit MemoDose in order to change pump speed (and direction). After returning to MemoDose, the pump dispenses the previous dose size at the new speed.



- Press the **STOP** key twice within half a second. The pump displays the manual mode main screen.
- **Do not start the pump. Doing so erases the previously recorded master dose and replaces it in the pump's memory with the current, unmeasured dose.** Adjust the speed showing on the display using the **UP** or **DOWN** keys.

- Press the **STOP** key twice within half a second to return to MemoDose. The display shows the previous percentage dose size. The pump will dose at the new speed.

Note: To retain the MemoDose value through a power interruption the pump must be in auto-restart mode. The dosing cycle will resume at the start of a dose and wait for **START** to be pressed, with the MemoDose percentage screen displayed. See 18.6 *Auto-restart*.

BpN, Bp

21 Exit

Press **Exit** in the Main menu to return to the Manual mode main screen.

BpN, Bp

22 PROFIBUS network control wiring and leak detection device wiring

Interfacing the pump with other devices is by means of 9-pin D-connectors positioned on the rear of the pump. IP66 models' D-connectors are within the watertight module. The module must be removed to allow these operations and refitted.

Bp

22.1 520N module removal and replacement

To remove the 520N watertight module:

The module is secured to the back of the drive unit by six M5x12 Pozidriv counter-sunk stainless steel screws.



- Remove the six screws using a suitable crosspoint screwdriver, leaving the top centre screw till last. Even when all screws have been removed, the sealing strip may cause the module to adhere to the drive. If so, a gentle tap will free it. Do not use a tool to lever it off.
- The sealing strip should be retained within its channel on the face of the module. The transparent on/off switch cover should be retained on its flange on the face of the module. Check the integrity of the seal and the transparent on/off switch cover. If either is damaged, it must be renewed to maintain ingress protection.
- If necessary, remove the module's earth link from the back of the drive. However, the link is long enough to allow the module to fold back to give access to the back of the drive.

To replace the 520N watertight module:



- Check that the fuse in the fuseholder (ringed) does not need to be replaced. Check that the voltage selector switch is correctly set.
- Check that the sealing strip is fully in its channel on the face of the module.
- Attach the module's earth link wire. Replace and tighten its screw to 2Nm.
- Push home any 9-pin D-connectors on to their counterparts on the rear of the drive and tighten their locking screws.
- Hold the module in place. Do not disturb the seal or pinch the earth link wire or D-connector cables, and screw in the retaining screws (top centre first). Tighten to 2.5Nm

Note: The 520N module must be properly fitted using all six screws. Without them, the screw holes may corrode and IP66 (NEMA4X) protection will be compromised.

22.2 Wiring up

22.2.1 PROFIBUS wiring

Note: For full details on PROFIBUS cabling, refer to *PROFIBUS Installation Guideline for Cabling and Assembly*, published by PROFIBUS International.

Interfacing the pump with other PROFIBUS devices is by means of a dedicated PROFIBUS female 9-pin D-connector positioned on the rear of the pump (within the 520N watertight module, if the pump is a 520BpN). Cable suitable for use in PROFIBUS DP installations must be used.

BpN

The cable must be passed into the module through a watertight cable gland and wired according to PROFIBUS recommendations to the IN terminals of a dedicated PROFIBUS male 9-pin D-connector (not supplied), which is plugged into the dedicated PROFIBUS female 9-pin D-connector. The cable must be circular in section, 4.5mm-9.5mm in diameter to ensure a seal within the gland.



- Use a 19mm spanner to unscrew the sealing plug. Discard the nylon sealing washer.
- Screw in one of the supplied M16x1.5 cable glands in place of the plug, using the new nylon sealing washer supplied. Tighten the gland to 2.5Nm to ensure a seal, using a 21mm spanner. If a different gland is used, it must be watertight to IP66.
- Loosen the gland cap (do not remove it) and pass the PROFIBUS cable in through the gland.
- Pull through sufficient cable to allow convenient connection to a dedicated PROFIBUS male 9-pin D-connector.

Note: Users are advised to pass PROFIBUS cables through the module glands nearest to the switch cover. Doing so will minimise bends in the cables when the module is attached to the back of the pump.



BpN, Bp



- Connect to the IN terminals of a dedicated PROFIBUS male 9-pin D-connector, following the directions supplied with the connector. An example is shown here.

BpN



- If the pump IS NOT the last device on its PROFIBUS communication line, a second cable must be passed into the module through another watertight cable gland and wired according to PROFIBUS recommendations to the OUT terminals of the dedicated PROFIBUS male 9-pin D-connector and to the next device on the PROFIBUS network line.

Bp

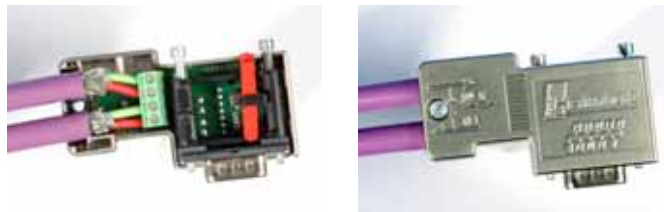

- If the pump IS NOT the last device on its PROFIBUS communication line, a second cable must be wired according to PROFIBUS recommendations to the OUT terminals of the dedicated PROFIBUS male 9-pin D-connector and to the next device on the PROFIBUS network line.

BpN, Bp



- If the pump IS NOT the last device on its PROFIBUS communication line, move the terminator switch built into the dedicated PROFIBUS male 9-pin D-connector to OFF.
- If the pump IS the last device on its PROFIBUS communication line, move the terminator switch built into the dedicated PROFIBUS male 9-pin D-connector to ON.



BpN

- Push home the dedicated PROFIBUS male 9-pin D-connector on to its counterpart on the rear of the drive (top D-connector) and tighten its locking screws.
- As the module is brought into alignment with the rear of the pump ready to fix it into position, gently pull cable through the glands to reduce the length of cable within the module to an appropriate length.
- Refit the 520N module as described above: see 22.1 *520N module removal and replacement*. Tighten gland caps to 2.5Nm.

BpN, Bp



Avoid sharp bends in PROFIBUS communication cables.



It is important to check that the pump's voltage setting matches the supply. The voltage selection switch is on the rear panel of the drive. If the pump is a 520BpN, the module must be removed (and replaced) to allow it to be checked.

22.2.2 Wiring leak detection devices

Fit a Watson-Marlow tube monitor or leak detector according to the directions supplied with the device.

23 Switching to PROFIBUS network control

Note: The pump can be switched to PROFIBUS network control only if PROFIBUS is enabled. See 8 *Pump specifications*, 18.1 *Pump address* and 18.2 *PROFIBUS enable*.

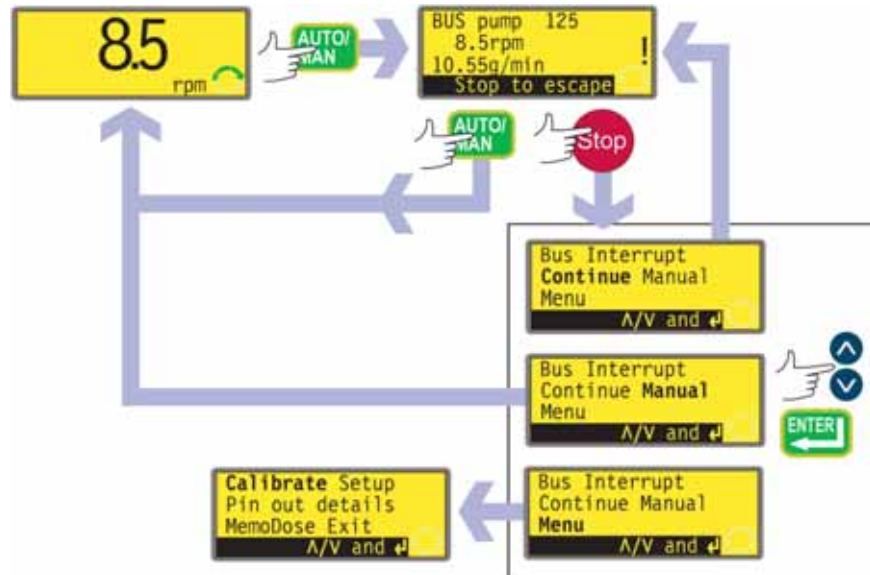

How to get into PROFIBUS network operation

- While the manual mode main screen is displayed, press the **AUTO/MAN** key.
- The pump stops (if it was pumping while under manual control). It is now under PROFIBUS control, waiting for a PROFIBUS telegram from the PROFIBUS master. It displays its PROFIBUS address, and its speed, direction of rotation and flowrate from its previous manual operation. It is automatically switched into auto-restart mode and displays the ! icon. The only keys active are **STOP** and **AUTO/MAN**.
- Leak input is active. See 24.1 *Error codes*.

Note: If PROFIBUS is not enabled (see 18.2 *PROFIBUS enable*) when **AUTO/MAN** is pressed, the keypress is ignored.



WARNING: When switched to PROFIBUS control the pump may start unexpectedly.

How to get out of PROFIBUS network operation

- Pressing the **AUTO/MAN** key returns the pump to manual control. It retains the set speed and run status from its previous PROFIBUS operation: if it was running it continues to run; if it was stopped it remains stopped. Auto-restart is cancelled unless it was in place the last time the pump was under manual control. All keys are now active.

Note: While the pump is under manual control, it responds to interrogation by the PROFIBUS master if it is connected to a PROFIBUS network (see 22.2.1 *PROFIBUS wiring*) and PROFIBUS is enabled (see 18.2 *PROFIBUS enable*).

Emergency stop

- In an emergency while the pump is under PROFIBUS control press the **STOP** key. The pump stops and displays an interruption screen.
 - Select **Continue** to return to PROFIBUS control. The pump remains stopped, displays the set speed and run status from its previous PROFIBUS operation and waits for a PROFIBUS telegram from the PROFIBUS master.
 - Select **Manual** to set the pump to manual control (see 14 *Manual operation*). The pump remains stopped and displays the set speed and run status from its previous PROFIBUS operation. Auto-restart is cancelled unless it was in place the last time the pump was under manual control. All keys are now active.
 - Select **Menu** to display the main menu (see 15 *Main menu*).
 - Use the **UP** and **DOWN** keys to choose and press **ENTER** to confirm.

23.1 PROFIBUS GSD file

The Watson-Marlow 520BpN and 520Bp can be integrated into a PROFIBUS DP V0 network using a General Station Data (GSD) file. The file identifies the pump and contains key data including its communication settings, the commands it can receive and the diagnostic information it can pass to the PROFIBUS master on interrogation.

The GSD file—file name WMFP0A9F.GSD—can be installed from the CDROM supplied with this pump; or downloaded from the Watson-Marlow website and installed; or typed into a PROFIBUS master directly from this manual using a GSD editor program.

Note: The data-flow to and from the pump may need to be byte-reversed, due to differences of handling the data between suppliers of master devices.

The GSD file, filename: WMFP0A9F.GSD

```

;*****
;***
;***   Watson-Marlow Bredel Pumps   ***
;***   Bickland Water Road         ***
;***   Falmouth                    ***
;***   Cornwall                     ***
;***   TR11 4RU                     ***
;***   ENGLAND                      ***
;***   Telephone:      +44 (1326) 370370 ***
;***   Fax:            +44 (1326) 376009 ***
;***
;*****
;***
;***   Filename: WMFP0A9F.GSD       (c) 2007 ***
;***   GSD file version 1 from    20.09.2007 ***
;***
;*****
;
;   ATTENTION:
;   =====
;   Changes in this file can cause configuration or communication problems.
;   This file is compatible to the firmware of the device.
;
;   Changes
;   =====
;   20.09.2007   V1.000   I. Guffick   -   created

#PROFIBUS_DP

GSD_Revision           = 1
Vendor_Name            = "Watson Marlow"
Model_Name             = "Pump 520/620/720"
Revision               = "Version 1.000"
Ident_Number          = 0x0A9F
Protocol_Ident        = 0
Station_Type          = 0
Hardware_Release      = "Version 1.000"
Software_Release      = "Version 1.000"
Implementation_Type   = "netX"
9.6_supp              = 1
19.2_supp             = 1
45.45_supp            = 1
93.75_supp            = 1
187.5_supp            = 1
500_supp              = 1
1.5M_supp             = 1
3M_supp               = 1
6M_supp               = 1
12M_supp              = 1
MaxTsdR_9.6           = 60
MaxTsdR_19.2          = 60
MaxTsdR_45.45         = 60
MaxTsdR_93.75         = 60
MaxTsdR_187.5         = 60
MaxTsdR_500           = 100
MaxTsdR_1.5M          = 150
MaxTsdR_3M            = 250
MaxTsdR_6M            = 450
MaxTsdR_12M           = 800
Redundancy             = 0
Repeater_Ctrl_Sig     = 2
24V_Pins              = 0
Freeze_Mode_supp     = 0
Sync_Mode_supp        = 0
Auto_Baud_supp        = 1
Set_Slave_Add_supp   = 1
Min_Slave_Intervall   = 6
Modular_Station       = 0
Max_Diag_Data_Len     = 244
Slave_Family           = 0

User_Prm_Data_Len     = 6
User_Prm_Data         = 0x00, 0x00, 0x00, 0x00, 0x00, 0x00

Bitmap_Device         = "NXDPSR"
Bitmap_Diag           = "NXDPSD"
Bitmap_SF             = "NXDPSS"

Module                 = "WM pump, 3/6 word out/in" 0x62,0x55
1
EndModule

```

23.2 PROFIBUS data exchange

The data in this section are provided as reference material for a PROFIBUS network operator. Operating this pump under PROFIBUS control is beyond the scope of this instruction manual. Consult your PROFIBUS network literature for further information.

Default address: 126		Note: The data-flow to and from the pump may need to be byte-reversed, due to data-handling differences between master devices.
PROFIBUS Ident: 0x0A9F		
GSD File: WMFP0A9F.GSD		
Config: 0x62, 0x55 (3 words out, 6 words in)		
User Parameter bytes: 6		
Cyclic Data Write (from Master to pump)		
16 bit	Control Word	
16 bit	Speed Setpoint	
16 bit	Set FlowCalibration in μ l per revolution	
Cyclic Data Read (from pump to Master)		
16 bit	Status Word	
16 bit	Measured Speed	
16 bit	Hours Run	
32 bit	Tacho Counter *	
16 bit	Read FlowCalibration in μ l per revolution	
User Parameter Data		
8 bit	Pump Model	
8 bit	Head Type	
8 bit	Min Speed (High byte) (not 520BpN and 520Bp)	
8 bit	Min Speed (Low byte) (not 520BpN and 520Bp)	
8 bit	Max Speed (High byte)	
8 bit	Max Speed (Low byte)	
Extended Diagnostic Data		
Device Related Diagnostic Data		
16 bit	Pump Model and Head	
16 bit	Tubing Size	
16 bit	Min Speed	
16 bit	Max Speed	
32 bit	Software Version H8 (pump)	
32 bit	Software Version netX (PROFIBUS)	
Channel Related Diagnostic Data		
Global error	= 0xA9 (General error)	
Guard open	= 0xB0 (Device related 0x10) (not 520BpN and 520Bp)	
Over current	= 0xA1 (Short circuit)	
Under voltage	= 0xA2 (Under voltage)	
Over voltage	= 0xA3 (Over voltage)	
Over temp	= 0xA5 (Over temp)	
Motor stall	= 0xA4 (Overload)	
Tacho fault	= 0xB1 (Device related 0x11)	
Leak detect	= 0xB2 (Device related 0x12)	
Setpoint out of range - low	= 0xA8 (Lower limit exceeded)	
Setpoint out of range - high	= 0xA7 (Upper limit exceeded)	

Control word	
Bit	Description
0	Motor on/off (1=On)
1	Direction (0=CW, 1=CCW)
2	Tacho Reset (1=Reset Count)
3	Guard Error Reset (1=Reset)
4	Enable Fieldbus Min/Max Speeds (1=Enabled)
5	Enable Fieldbus Flow Calibration (1=Enabled)
6-15	Reserved (0)

Status Word	
Bit	Description
0	Motor running (1=running)
1	Global Error Flag (1=Error)
2	Fieldbus Control (1=Enabled)
3	Guard Status (1=Open)
4	Over current error
5	Under voltage error
6	Over voltage error
7	Over temperature error
8	Motor stalled
9	Tacho fault
10	Leak detected
11	Low Setpoint - Out of range
12	High Setpoint - Out of range
13-15	Reserved (0)

Pump Model and Pumphead	
Value	Description
0x01--	520 Drive
0x02--	620 Drive
0x03--	720 Drive
0x--00	520R head
0x--01	520REL head
0x--02	520REM head
0x--03	520REH head
0x--04	505L head
0x--05	313 head
0x--06	314 head
0x--07	501RL head
0x--08	505BA head
0x--09	505CA head
0x--0A	314MC head
0x--0B	318MC head
0x--40	620R head
0x--41	620RE head
0x--42	620RE4 head
0x--43	620L head
0x--80	720R head
0x--81	720RE head

Note: Numerical values cannot include a decimal point. To enter a speed, move the decimal point one place to the right and enter an integer. To enter a tube size, move the decimal point two places to the right and enter an integer. See examples below

Data examples	
speed	value
123.4	1234
tube size	value
2.38	238
9.6	960
25.4	2540

* **Note:** If the pump is run at full speed, the PROFIBUS tacho count will be reset after:

520: 30 hours	620: 25 hours	720: 48 hours
---------------	---------------	---------------

23.3 PROFIBUS network operation

Operating this pump under PROFIBUS control is beyond the scope of this instruction manual. See 8 *Pump specifications* for PROFIBUS/520BpN and 520Bp capability. Consult your PROFIBUS network literature for further information.

BpN, Bp

24 Troubleshooting

If the pump display remains blank when the pump is on, make the following checks:

- Check the position of the voltage selector switch. The voltage selector is mounted in the switchplate at the rear of the pump, protected from water by the 520N module. The module must be removed to allow access to the switchplate. See 22.1 *520N module removal and replacement*.
- Check the mains power switch at the rear of the pump.
- Check that mains power is available to the pump.
- Check the fuse in the fuseholder in the centre of the switchplate at the rear of the pump.
- Check the fuse in the mains power plug if one is present.

If the pump runs but there is little or no flow, make the following checks:

- Check that the tube and rotor are in the pumphead.
- Check that fluid is supplied to the pump.
- Check that the tube is not split or burst.
- Check for any kinks or blockages in the lines.
- Check that any valves in the lines are open.
- Check that the correct wall-thickness tube is being used.
- Check direction of rotation.
- Check that the rotor is not slipping on the drive shaft.

If the pump is not controllable under PROFIBUS, make the following checks:

- Check that PROFIBUS wiring has been installed correctly.
- Check that the pump's PROFIBUS address has been set and that PROFIBUS is enabled.
- Check that the pump has been switched to PROFIBUS control using the **AUTO/MAN** key.
- Check that the pump is not displaying an error message.
- Check that the PROFIBUS master has not diagnosed a problem with the pump or its connection.

If trouble persists, technical assistance for this product is available from your distributor, or Watson-Marlow Ltd, Falmouth TR11 4RU, United Kingdom.

24.1 Error codes

If a system error (red error number) occurs, a flashing error screen is displayed on the pump display. Non-system error screens report the nature of an external signal. They do not flash. All errors except Error 0 and Error 35 are indicated through network diagnostics. Error 28 does not apply to 520 series pumps.

Error	Condition	Comments	Action
0	RAM Write error	POST will pick up initial errors	Try re-powering. Seek support if error persists. Note: this error is indicated at the pump only
9	Motor stalled	Hall and/or Tacho inputs stopped at unrecognised time	Try re-powering. Seek support if error persists
10	Tacho fault	Tacho input not as expected	Try re-powering. Seek support if error persists
11	Motor calibration lost	Hall effects calibration data lost	Seek support
14	Wrong speed	Picked up from Hall and/or Tacho inputs	Try re-powering. Seek support if error persists
15	Over current	Hardware detects an overcurrent condition and sends an interrupt for automatic shutdown	Check tubing and the system, or seek support
16	Over voltage	Check supply voltage input	Check supply, re-power or seek support
17	Under voltage		
19	Over temperature	Check ambient and pumping duty	Turn OFF to cool. Check duty and ambient temperature
28	Guard open	Guard switch hardware input detects open guard	Close pumphead then press Stop
29	Leak detected	Leak switch hardware input detects leak	Check and reset then press Stop
30	Network connection not present	Network unavailable or not connected	Check connection
31	Network communication lost mid-transmission	Network communications lost	Check master and connection
32	Network communications OK but parameter or address error	Network setup errors	Check parameters and address
35	I ² t/Current overload	Checks current average over time	Check system, re-power or seek support. Note: this error is indicated at the pump only
ERR	General error	Unrecognised or general error	Try re-powering. Seek support if error persists

BpN, Bp

25 Drive maintenance

There are no user serviceable parts inside the pump (except the power cable: see 10 *Connecting this product to a power supply*). The unit should be returned to Watson-Marlow or its appointed agents or distributors for service.

BpN, Bp

26 Drive spares

Replaceable main fuse, type T2,5A H 250V
20mm: FS0064

Foot: MN2507M

Module seal: MN2516B

Module switch cover:
MN2505M

Glands: GR0056

Blanking plugs: GR0057

Sealing washer for blanking plug and gland:
GR0058

Snap-fit vent: MN2513B

BpN, Bp

Pumphead use is independent of drive ingress protection. No reference to ingress protection rating or drive model (520BpN or 520Bp) is made throughout the pumphead sections of this manual.

27 The 505L pumphead

To overcome the pulsatile effect some peristaltic pumps exhibit, Watson-Marlow have developed the principle of twin offset tracks. This puts the two tubes out of phase, merging a pulse from one channel with a trough from the other.

The 505L is fitted with six stainless steel rollers and uses either silicone or Marprene tubing up to 9.6mm bore, 2.4mm wall thickness.

For most dispensing and low pulse applications, use Watson-Marlow double-Y tubing elements, which are pre-formed to the correct length to ensure accurate merging of flows to give the smoothest flow possible.

If you do not wish to use the special double-tube elements, a set of six tube clamps will allow the pumphead to be used with either twin inlet (suction) tubes or as a two channel (totally separate) precision pumphead.

27.1 505L pumphead fitting and removal



Always isolate the pump from the mains power supply before opening the guard or performing any positioning, removal or maintenance activity.

To fit and remove the pumphead



- Grease the drive shaft tongue. Position the pumphead centrally on the front face of the drive and manually turn the rotor until the slotted rotor shaft engages with the tongue of the drive shaft. Ensure that the two captive retaining bolts align with the top and bottom holes on the drive face.
- Use a 10ml spanner to tighten the retaining bolts to 3Nm.
- Position the adapter cover over the pumphead rear face plate and the captive retaining bolt heads. Click downwards into position.
- Reverse this procedure to remove the track.

To fit an extension pumphead

The front of the 505L pumphead is trimmed with a cover plate held in place with two screws. It must be removed before a second pumphead can be fitted.



- Lift the two levers at either side of the pumphead and remove the track.
- Remove the two screws securing the cover plate to the front of the fixed pumphead. A stubby crosspoint screwdriver may be convenient for this. Remove the cover plate.
- Grease the projecting shaft tongue at the rear of the extension pumphead and the slot at the front of the fixed pumphead. Position the extension pumphead so that the tongue and slot engage, and align the body of the extension pumphead with the body of the first, fixed, pumphead. Fit the two supplied extension pumphead fixing screws at each side of the extension pumphead and tighten. Secure the cover plate to the extension pumphead using the two screws which secured it to the fixed pumphead.
- Position the tracks and secure them by closing the levers.

28 505L tube loading



Always isolate the pump from the mains power supply before removing the track or performing any positioning, removal or maintenance activity.

Tube loading instructions are given for the three possible methods of using a 505L pumphead.

For most dispensing, and any application where there must be minimal pulsing, the use of Watson-Marlow double-Y silicone tubing elements is recommended. These are pre-formed to the correct length and merge two out-of-phase flows into a single smooth output. These elements fit on the bayonet-style retaining pegs supplied with the pumphead.

In certain circumstances it may be useful to run two separate inlet tubes from your source to the pumphead. It is advisable to do this if the fluid is particularly viscous and the single inlet tube is found to restrict the flow rate, or if the pump is situated a long distance from the source reservoir and is running at high speed. A tube clamp set is available from Watson-Marlow (see 31 *505L Pumphead spares*) to securely fix twin inlet tubes.

The 505L may also be used as a two-channel, six-roller, precision pumphead, with two entirely separate tubes. The tube clamp set contains two clamps for each suitable size of tubing to enable both the inlet and the delivery side to be secured. It should be noted that, when used in this way, the flow does not benefit from the smoothing created by combining two out-of-phase flows, and slight channel-to-channel variation may be found in the flow rates. Keeping suction and discharge tubing lengths the same will minimise this variation.

28.1 505L: fitting double-Y tubing elements

If using a standard element of any size:



- Lift the two levers at either side of the pumphead and remove the track.
- Stretch the tubing element slightly and locate it over the mushroom pegs either side of the pumphead.
- Replace the track and secure it by closing the two levers.

Note: When using Pumpsil 9.6mm elements, best results will be obtained from a High-flow element: part number 913.AH96.K24. Clamp MNA0345A is required to secure the element on the suction side of the pumphead.

If using a 9.6mm High-flow element:



- Lift the two levers at either side of the pumphead and remove the track.
- Remove the mushroom peg on the suction side of the pump by turning it counter-clockwise through one quarter turn and withdrawing it. Do not remove the peg on the delivery side.
- Lay the element across the rotor, with the smaller Y connector over the end peg on the delivery side.
- Tube clamps are marked with the nominal bore for their intended tubing. Pull the element taut and firmly secure it with a 9.6mm clamp on the suction side of the pumphead, using the bayonet-style fixing previously used for the mushroom peg.
- Replace the track and secure it by closing the two levers.

Transfer tubing may now be attached to the connectors. On the suction side, use 12.7mm bore tubing.

28.2 505L: using twin inlet tubes

Improved flow rates may be obtained by fitting two inlet tubes and using a Y connector to obtain a smooth flow.



- Lift the two levers at either side of the pumphead and remove the track.
- Remove the mushroom peg on the suction side of the pump by turning it counter-clockwise through one quarter turn and withdrawing it. Do not remove the peg on the delivery side.
- Fit two lengths of tube to the top branches of a Y connector. Lay this assembly across the rotor, with the Y connector over the end peg on the delivery side.
- Tube clamps are available, marked with the nominal bore for their intended tubing. Pull the two lengths of tube taut and firmly secure them with a correctly-sized clamp on the suction side of the pumphead, using the bayonet-style fixing previously used for the mushroom peg. You may find it convenient to insert the tubes into the arches of the clamp before securing the clamp.
- Replace the track and secure it by closing the two levers.

Transfer tubing may now be attached to the connectors.

28.3 505L: using two independent tubes

This option may be used to allow the 520L to function as a twin-channel pumphead.



- Lift the two levers at either side of the pumphead and remove the track.
 - Remove the mushroom peg on both sides of the pump by turning it counter-clockwise through one quarter turn and withdrawing it.
 - Mark a length of 145mm on two lengths of tube up to a bore size of 8.0mm; or mark a length of 150mm on two lengths of 9.6mm bore tubing.
 - Tube clamps are marked with the nominal bore for their intended tubing. Secure the tubes to the suction side of the pumphead with a correctly-sized clamp, aligning one of the marks on each tube with the inner face of the clamp. Secure the clamp by inserting the fixing bayonet into the socket previously used for the mushroom peg and rotating it clockwise one-quarter turn.
 - Stretch the tubes slightly and secure them with the second clamp in the same way, with the second pair of marks aligned with the inside of the second clamp. You may find it convenient to insert the tubes into the arches of the second clamp before securing the clamp.
 - Replace the track and secure it by closing the two levers.
- Note:** After fitting new lengths of Marprene tubing, run the pump for about half an hour and then re-tension the tubing, making sure that the nominal lengths above are restored. If tubing lengths greater than those given are used, the tubing may move about within the pumphead and damage will occur.

505L tube clamps	
Full set: 059.4001.000	
1.6mm bore: MNA0340A	3.2mm bore: MNA0341A
4.8mm bore: MNA0342A	6.4mm bore: MNA0343A
8.0mm bore: MNA0344A	9.6mm bore: MNA0345A

29 505L maintenance



Always isolate the pump from the mains power supply before removing the track or performing any positioning, removal or maintenance activity.

The 505L pumphead is maintenance-free - although it is wise to check the moving parts of the rotor from time to time to ensure that the rotor and its rollers move freely.

If aggressive liquids are spilled on the pumphead, it should be removed and cleaned. Do not use strong solvents.

General guide to cleaning with solvents

Chemical	Cleaning precautions
Aliphatic hydrocarbons	Minimise bearing seals' exposure to less than one minute (risk of attack).
Aromatic hydrocarbons	Minimise bearing seals' exposure to less than one minute (risk of attack).
Ketone solvents	Minimise bearing seals' exposure to less than one minute (risk of attack).
Halogenated/chlorinated solvents	Minimise bearing seals' exposure to less than one minute (risk of attack).
Alcohols, general	No precaution necessary.
Glycols	No precaution necessary.
Ester solvents	Minimise bearing seals' exposure to less than one minute (risk of attack).
Ether solvents	Minimise bearing seals' exposure to less than one minute (risk of attack).

30 505L track adjustment

The track is set for use with 2.4mm wall tubing with bore sizes from 1.6mm to 9.6mm. Do not attempt to change the 14.3mm (0.56in) gap between the track and the top of the pumphead.

31 505L pumphead spares



1	MNA0338A	Adaptor plate
2	BB0014	Drive shaft bearing
3	MNA0371A	Rotor assembly
4	MN0862S	Cover plate
5	MN1029C	End plate
6	MNA0339A	Tube-locating mushroom peg (two required)
7	MNA0333A	Track assembly
8	059.4001.000	Tube clamp set: includes two clamps for each of the six tube sizes

32 505L Flow rates

Pumping conditions

All performance figures in this operating instruction have been recorded against peak pipeline pressures.

Flow rates are normalised test values obtained using new tubing, pumping water at 20C with negligible inlet and discharge pressures. Actual flow rates achieved may vary because of changes in temperature, viscosity, inlet and discharge pressures, system configuration and tubing performance against time. Flow rates may also vary due to normal manufacturing tolerances of the tubing. These tolerances will make flow rate variance more pronounced at smaller bore sizes.

For precise and repeatable performance it is important to determine flow rates under operating conditions for each new piece of tubing.



505L pumpheads' flow rates are directly proportional to rotor speed. If you wish to run the pump at a speed not shown in the tables below, flow figures can be reached by dividing the maximum flow shown in the tables below by the maximum rpm figure, and multiplying the result by your required speed in rpm.

505L (ml/min)									
Min	Max	Ratio	Speed range	1.6mm	3.2mm	4.8mm	6.4mm	8.0mm	9.6mm
0.1	350	3500:1	0.1 to 350 rpm	0.04-150	0.23-800	0.42-1500	0.70-2500	0.90-3200	1.3-4400 *

* **Note:** Using 913.AH96.K24 High-flow element.

33 505L tubing part numbers

2.4mm wall Double Y elements for 505L pumpheads

					
mm	inch	#	Marprene	Bioprene	Pumpsil
1.6	1/16	119	902.E016.K24	903.E016.K24	913.AE16.K24
3.2	1/8	120	902.E032.K24	903.E032.K24	913.AE32.K24
4.8	3/16	15	902.E048.K24	903.E048.K24	913.AE48.K24
6.4	1/4	24	902.E064.K24	903.E064.K24	913.AE64.K24
8.0	5/16	121	902.E080.K24	903.E080.K24	913.AE80.K24
9.6	3/8	122	902.E096.K24	903.E096.K24	913.AE96.K24
9.6	3/8	122			913.AH96.K24 (High flow)
mm	inch	#	Chem-Sure	Sta-Pure	
1.6	1/16	119	965.E016.K24	960.E016.K24	
3.2	1/8	120	965.E032.K24	960.E032.K24	
4.8	3/16	15	965.E048.K24	960.E048.K24	
6.4	1/4	24	965.E064.K24	960.E064.K24	
8.0	5/16	121	965.E080.K24	960.E080.K24	

2.4mm wall tubing for 505L pumpheads operating as a twin-channel pump

See 2.4mm wall tubing table in 40 520R, 520R2 and 520RE: tubing and element part numbers

Y connectors for 505L pumpheads

Description	Pack of 20
For 1.6mm bore	999.3016.K00
For 3.2mm bore	999.3032.K00
For 4.8mm bore	999.3048.K00
For 6.4mm bore	999.3064.K00
For 8.0mm and 9.6mm	999.3096.K00

34 The 520R, 520R2 and 520RE pumpheads

Identification of parts



520R/520R2		520REL/520REM/520REH			
1	Guard latch	5	Rotor cap	9	Pumping roller
2	Guard (520R, 520R2)	6	Tube guide roller	10	Tube clamp slider (520R, 520R2)
3	Track	7	Rotor	11	Tube clamp (520R, 520R2)
4	Clutch button cover	8	Follower roller	12	Guard with seal (520RE)
				13	Drain port (520RE)

34.1 Pumphead position, removal and replacement



Always isolate the pump from the mains power supply before opening the guard or performing any positioning, removal or maintenance activity.

The pumphead track can be fitted in one of three orientations to provide right, up or down input/output port positions, whichever is convenient. Position the pumphead so that the tube ports face up or down only where the drive is placed on the bench edge - otherwise the pump tube or the hinged guard will impact the bench. Do not position the pumphead so that the tube ports face the keypad. Doing so may result in a safety risk.

The pump can be configured for clockwise or counter-clockwise rotor rotation. Please note, however, that tube life will be greater if the rotor rotates clockwise; and that performance against pressure will be maximised if the rotor rotates counter-clockwise.

To reposition the track

- Open the pumphead guard as described at 28.1 *Opening the pumphead guard*.
- Remove the rotor as described under *Rotor removal*, below.
- Undo and withdraw the four track-retaining screws using a slotted screwdriver.



- Remove the track.
- Relocate the track in the desired position. Replace and tighten the track-retaining screws.
- Replace the rotor as described under *Rotor replacement* below.
- Close the guard, pushing it fully home until the latch engages.

Rotor removal

- Remove any tubing from the pumphead.

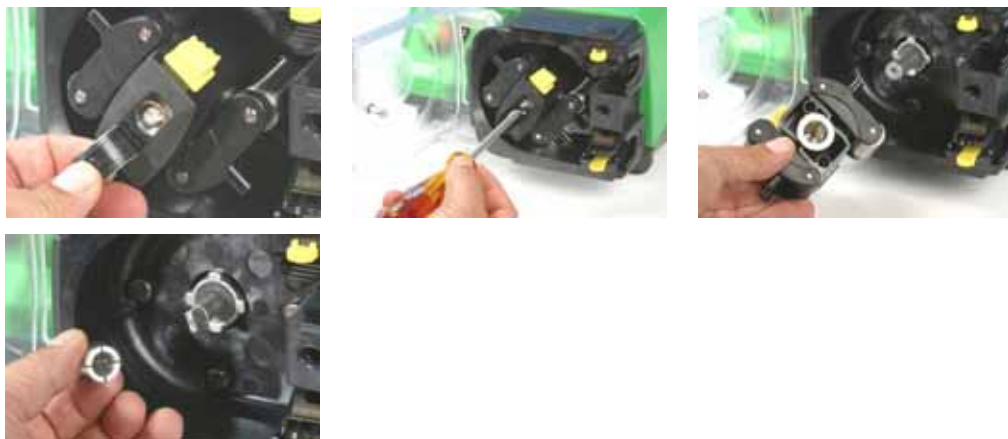

- Open the flexible rotor cap in the centre of the rotor.
- Undo and withdraw the central locating screw using a slotted screwdriver.
- Pull the rotor hub off its dogged shaft.
- Between the hub and the shaft is a split collet. If the collet is retained by the shaft, pull it off, loosening it if necessary by tapping it lightly. Avoid levering it off using a screwdriver or other tool. If the collet is retained within the hub, remove it, loosening it if necessary by reinserting the central locating screw a turn or two and tapping the screw head lightly.

Rotor replacement

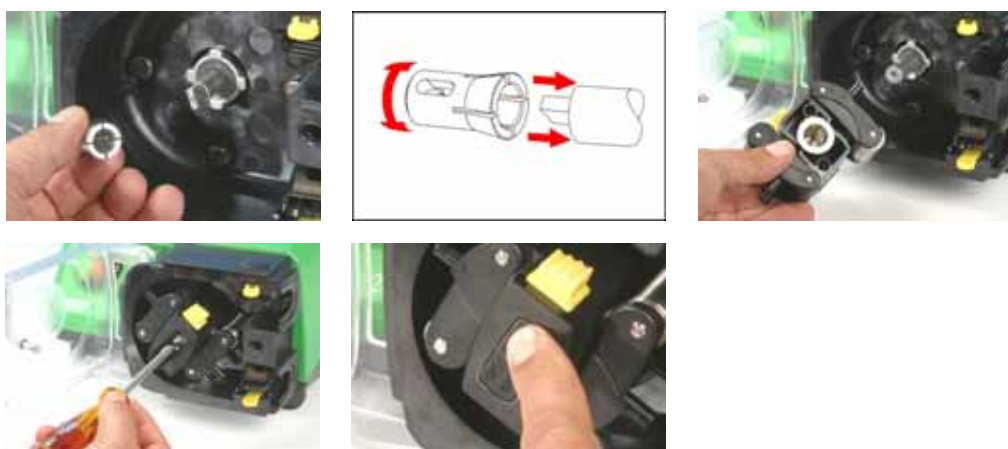

- Re-locate the split collet onto the drive shaft, rotating it until it fully engages the dog. Fit the rotor body over the drive shaft.
- Open the flexible rotor cap in the centre of the rotor. Use a slotted screwdriver to tighten the central locating screw to a torque of 3Nm (2.2 lb-ft) to prevent collet slip during operation. When fitted correctly, the tube guide rollers should align with the outer face of the track. Close the flexible rotor cap.
- Close the guard and ensure that the rotor is clear of the guard by observing the first few rotor rotations.

35 520R, 520R2 and 520RE installation



Always isolate the pump from the mains power supply before opening the guard or performing any positioning, removal or maintenance activity.

35.1 Opening the pumphead guard

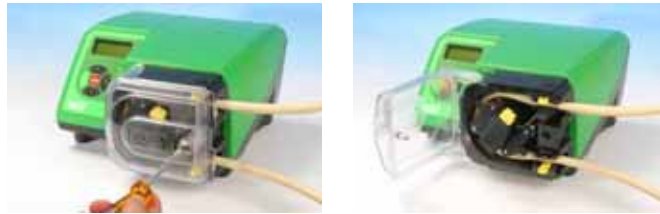

- Unlock the pumphead guard by turning the guard fastener $\frac{1}{4}$ turn anticlockwise with a slotted screwdriver.
- Open the guard to its full extent to create maximum clearance for the tube ports.
- Ensure that the rollers rotate freely and that the tube clamps are clean.

35.2 520R and 520R2 tube loading

520R continuous tubing pumpheads are factory-set to accept Watson-Marlow 1.6mm-wall tubing. 520R2 continuous tubing pumpheads are factory set to accept Watson-Marlow 2.4mm-wall tubing. Pumping performance may be adversely affected if Watson-Marlow tubing is not used.



- Mark a 225mm (8 ⁷/₈ in) length onto the section of the tubing which is to be located into the pumphead. **Caution:** Placing more than 225mm (8 ⁷/₈ in) of tube inside the pumphead may result in reduced tube life.
- Open the lower spring-loaded tube clamp and locate the tubing, with the first 225mm (8 ⁷/₈ in) length mark aligned to the inside face of the spring-loaded part of the tube clamp. Release the clamp.
- Disengage the rotor clutch by fully depressing the yellow clutch button on the side of the rotor hub and turning the hub a few degrees while the clutch button is still depressed. The rotor can now rotate independently of the gearbox and motor for one full revolution. If the clutch re-engages before tube fitting is complete, depress the clutch button again and turn the rotor a few degrees.
- Feed the tubing around the pumphead track, turning the rotor as necessary. Make sure the tubing is not twisted or pinched between the guide rollers and the track. Ensure that the second 225mm (8 ⁷/₈ in) mark is adjacent to the inner edge of the upper tube clamp.
- Open the upper spring-loaded tube clamp and locate the tubing into it, making sure there is no residual twist in the tubing, and that the tube sits centrally between the tube guide rollers. Release the clamp.



- The spring-loaded tube clamps must grip the tubing tightly enough to stop it moving in and out of the pumphead but must not over-squeeze the tube and throttle fluid flow. The tubing clamps are fitted with yellow sliders which can be clicked into two positions while the clamps are held open: the outer position will allow the clamps to grip the tube tightly; the inner will grip the tube loosely. Adjust the sliders to prevent tube movement during a few trial rotations of the rotor.
- Close the guard, pushing it fully home until the latch engages.
- Connect suitable pipework to the pumphead tubing using appropriate connectors.
- Remember, when using Marprene or Bioprene tubing, re-tension the tubing after 30 minutes of running, as it may grow in length as it beds in. Re-tension so that 225mm (8 ⁷/₈ in) of tubing sits between the inside faces of the spring-loaded parts of the tube clamps.

35.3 520RE: fitting the drain port

The drain port is an optional extra, supplied with the pumphead. It is strongly recommended that users fit it before the pump is operated. It may be done with the rotor in position or removed.





- Remove the drain plug from the bottom of the pumphead. The drain plug is flexible. It may be removed using finger pressure from within the pumphead, or by accessing its flange from outside with a fingernail.
- Drop the port into position from inside the pumphead.
- Fit the supplied port retaining nut (³/₈ in BSP) and finger-tighten.
- Fit drainage pipework as required (not supplied).

35.4 520RE element loading

520RE tubing element pumpheads are factory-set to accept Watson-Marlow 2.4mm-wall tubing elements. Elements fitted with either quick-release industrial connectors or Tri-clamp sanitary connectors may be used; however, **it is vital to match the pressure rating of the element with the pressure rating of the pumphead** so that the correct roller-spring rate and occlusion settings are used. The pressure rating of the pumphead appears on the flexible rotor cap in the centre of the rotor. The pressure rating of the element appears on the connector sleeve.

Note that the rotor cap and the element connector sleeve are colour-coded.

Note: To achieve 4 bar and 7 bar pressures using a 520RE pump and the appropriate rotor and element, the pump **must** rotate counter-clockwise.

Element and rotor pressure ratings					
Colour of flexible rotor cap and element connector sleeve					
Grey		Beige		Blue	
					
520REL Pressures up to 2 bar (30 psi) Bore sizes 3.2mm, 6.4mm and 9.6mm		520REM Pressures up to 4 bar (60 psi) Bore sizes 3.2mm and 6.4mm		520REH Pressures up to 7 bar (100 psi) Bore size 3.2mm	
Industrial Marprene TL Pumpsil Neoprene Chem-Sure	Sanitary Bioprene TL Pumpsil Sta-Pure Chem-Sure	Industrial Marprene TM Chem-Sure	Sanitary Bioprene TM Sta-Pure	Industrial Marprene TH Sta-Pure	Sanitary Bioprene TH Sta-Pure

Element connectors for industrial and sanitary use	
Industrial	Sanitary
	



Check that the conical connector sleeve of the element to be fitted is the same colour as the pumphead rotor cap

520RE element loading procedure

Note: The element loading procedure is the same for industrial (pictured) and sanitary elements.



- Select an appropriate Watson-Marlow 520RE tubing element, paying attention to pressure capability, bore size, tubing material and type of connector. See the table above for pressure ratings. **Check that the connector sleeve of the element to be fitted is the same colour as the pumphead rotor cap.**
- Slide the connector D-flange at one end of the element into the lower connector D-slot.
- Disengage the rotor clutch by fully depressing the yellow clutch button on the side of the rotor hub and turning the hub a few degrees while the clutch button is still depressed. The rotor can now rotate independently of the gearbox and motor for one full revolution. If the clutch re-engages before tube fitting is complete, depress the clutch button again and turn the rotor a few degrees.
- Feed the tubing element around the pumphead track, turning the rotor as necessary. Make sure the tubing is not twisted or pinched between the guide rollers and the track.
- Slide the second connector D-flange into the upper connector D-slot.
- Check that the element lies in the middle of the track and that the connector flanges are pushed fully home.
- Close the guard, pushing it fully home until the latch engages.
- Connect suitable pipework to the pumphead tubing using appropriate connectors. See below.

35.5 520RE element connection

Select suitable tubing to connect to the tubing element supply and discharge connectors. Check that its pressure rating is appropriate to the application.

Sanitary $\frac{3}{4}$ in mini-Tri-clamp connectors

Sanitary connectors are connected to a tubing system using mini-Tri-clamps and gaskets.



- Hold the connector end of the supply or discharge tube against the element connector, with a gasket between them.
- Use a Tri-clamp to engage both flanges squarely, close it and tighten.

Industrial quick-release connectors

Industrial connectors are connected to a tubing system using quick-release fittings.



- Hold the pump securely and push the female fitting (available from Watson-Marlow Bredel) over the element until it clicks into place.



- To disconnect, hold the pump securely and pull the connector outer sleeve and twist counter-clockwise while pulling the female connector away.

36 520R, 520R2 and 520RE maintenance



Always isolate the pump from the mains power supply before opening the guard or performing any positioning, removal or maintenance activity.

- As part of regular cleaning and maintenance (and at least every three months), lubricate the pivot points, the follower rollers and the tube guide rollers with Ultra Lube (PA 1240), which is a non-toxic perfluoroether-based grease.
- The stainless steel pumping rollers run on externally-sealed bearings and are lubricated for life.
- Check that the pumphead track, rotor, rollers and spring-loaded tube clamps (if fitted) are clean and operating properly.
- If fluid is spilled inside the pumphead it should be cleaned as soon as possible, as reducing exposure time to contamination will prolong pumphead service life.
- To clean the pumphead, remove the rotor as described under *Rotor removal*, above. Flush the pumphead out with water and mild detergent, or suitable cleaning agent. Clean the rotor and rollers in the same way. If specific cleaning agents are required to clean the spillage, consult the general guide to cleaning with solvents below or Watson-Marlow after-sales office before proceeding, in order to confirm chemical compatibility. **Note:** the pumphead guard, rotor cap and clutch boot should be removed in advance of some cleaning regimes. See the table below. These components are available as spares if damaged.
- Replace the rotor as described under *Rotor replacement*, above.

General guide to cleaning with solvents

Chemical	Cleaning precautions
Aliphatic hydrocarbons	Remove guard. Minimise rotor cap and clutch boot exposure to less than one minute (risk of attack). Re-lubricate follower and tube guide rollers.
Aromatic hydrocarbons	Remove guard. Minimise rotor cap and clutch boot exposure to less than one minute (risk of attack). Re-lubricate follower and tube guide rollers.
Ketone solvents	Remove guard. Minimise rotor cap and clutch boot exposure to less than one minute (risk of attack). Re-lubricate follower and tube guide rollers.
Halogenated/chlorinated solvents	Not recommended: possible risk to polycarbonate tube clamp adjusters and polypropylene tube clamp locators.
Alcohols, general	No precaution necessary. Re-lubricate follower and tube guide rollers.
Glycols	Minimise rotor cap and clutch boot exposure to less than one minute (risk of attack). Re-lubricate follower and tube guide rollers.
Ester solvents	Remove guard. Minimise rotor cap and tube clamp location cap exposure to less than one minute (risk of attack). Re-lubricate follower and tube guide rollers.
Ether solvents	Not recommended: possible risk to polycarbonate tube clamp adjusters and polypropylene tube clamp locators.

37 520R, 520R2 and 520RE rotor settings

520R, 520R2 and 520RE pumpheads are factory-set to give optimum tube life with Watson-Marlow tubing and elements. Radial roller positions should not be adjusted in any circumstances as this will adversely affect pumphead performance and invalidate warranty. Tamper-proof rotor arm occlusion setting screws are fitted to warn operators from occlusion adjustment. Tubing with a wall thickness other than 1.6mm or 2.4mm can be used only with a pumphead set up for that purpose during manufacture. Contact Watson-Marlow after-sales.

38 520R, 520R2 and 520RE pumphead spares



520R/520R2	520REL/520REM/520REH
053.1011.100	520R
053.1011.2L0	520R2
053.1011.ELO	520REL
053.1011.EM0	520REM
053.1011.EH0	520REH
1 MNA2050A (520R, 520R2)	Pumphead guard complete with tool-unlockable latch
2 MNA2045A (520R, 520R2)	Track assembly for cased pumps complete with spring-loaded tube clamps
3 MNA2076A (520R - 1.6mm wall tube) MNA2077A (520R2 - 2.4mm wall tube) MNA2148A (grey) (520REL) MNA2149A (beige) (520REM) MNA2150A (blue) (520REH)	Rotor cover, rotor cap and clutch button
4 MN2011M S60022	Clutch Clutch spring
5 MNA2043A (520R - 1.6mm wall tube) MNA2001A (520R2 - 2.4mm wall tube) MNA2138A (520REL - 0-2 bar, 0-30 psi) MNA2139A (520REM - 2-4 bar, 30-60 psi) MNA2140A (520REH - 4-7 bar, 60-100 psi)	Rotor assembly complete with pumping rollers, follower rollers and tube guide rollers
6 MNA2006A (520R, 520R2) MN2002M (520R, 520R2) MN2131M (520RE)	Bottom (LH) tube clamp Tube clamp location plug Drain plug
7 MNA2005A (520R, 520R2) MN2002M (520R, 520R2)	Top (RH) tube clamp Tube clamp location plug
8 MN2034B MN2005M	Guard latch spring Guard latch spring cartridge
9 MNA2147A (520RE)	Pumphead guard complete with seal and tool-unlockable latch
10 MNA2144A (520RE)	Track assembly for cased pumps
11 MN2023T and MN2003T (520RE)	Drain port and nut

39 520R, 520R2 and 520RE flow rates

Pumping conditions

For precise and repeatable performance it is important to determine flow rates under operating conditions for each new piece of tubing.

When rotating counter-clockwise, 520R, 520R2 and 520RE pumpheads' flow rates are directly proportional to rotor speed. When rotating clockwise, 520R, 520R2 and 520RE pumpheads' flow rates are directly proportional to rotor speed up to 1.5 bar; their performance above 1.5 bar should be determined empirically.

Note: 520RE pumpheads should be used rotating counter-clockwise if pressures above 1.5 bar are required.

If you wish to run the pump at a speed not shown in the tables below, flow figures can be reached by dividing the maximum flow shown in the tables below by the maximum rpm figure, and multiplying the result by your required speed in rpm.

Actual flow rates achieved may vary because of changes in temperature, viscosity, inlet and discharge pressures, system configuration and tubing performance against time. Flow rates may also vary due to normal manufacturing tolerances of the tubing. These tolerances will make flow rate variance more pronounced at smaller bore sizes.

520R and 520R2

All performance figures for the 520R and 520R2 pumpheads have been recorded against peak pipeline pressures.

Although rated to 2bar (30psi) peak pressure, this pump will generate in excess of 2bar (30psi) peak pressure if the pipeline is restricted. Where it is important that 2bar (30psi) is not exceeded, pressure relief valves should be installed in the pipeline.

Viscosity handling is maximised by using 2.4mm wall tubing with the 520R2 pumphead.

Flow rates are normalised test values obtained using 225mm (8 ⁷/₈) of new tubing (measured from the inside faces of the tube clamps), and the pumphead rotating clockwise pumping water at 20C with negligible inlet and discharge pressures.

Note: Flow rates quoted are for 1.6mm and 2.4mm wall tubes. Tubes of 0.5mm and 0.8mm bore are only available in 1.6mm wall thickness except for platinum-cured silicone. Tubes of 9.6mm bore are only available in 2.4mm wall thickness.

520RE

Performance figures for the 520REL and 520REM have been recorded against 2bar peak pressure and 4bar peak pressure respectively.

Performance figures for the 520REH have been recorded against 7bar constant pressure.

Although the 520REL is rated to 2bar (30psi) peak pressure, the 520REM is rated to 4bar (60psi) peak pressure and the 520REH is rated to 7bar (100psi) constant pressure, the pumps will generate in excess of these pressures if the system pressures exceed this. Where it is important that these rated pressures are not exceeded, pressure relief valves should be installed in the pipeline.

Flow rates are normalised test values obtained using 520 elements and the pump-head rotating anticlockwise pumping water at 20C with negligible inlet and discharge pressures.

Continuous tubing

520R Neoprene, Sta-Pure, Chem-Sure, PVC, Pumpsil (ml/min)								
Speed range	0.5mm	0.8mm	1.6mm	3.2mm	4.8mm	6.4mm	8.0mm	9.6mm
520BpN/R, 520BpN/R2, 520Bp/R, 520Bp/R2								
0.1-220rpm	0.004-9.5	0.01-24	0.04-97	0.18-390	0.40-870	0.70-1500	1.1-2400	1.6-3500

520R Marprene / Bioprene 64 shore tubing (ml/min)								
Speed range	0.5mm	0.8mm	1.6mm	3.2mm	4.8mm	6.4mm	8.0mm	9.6mm
520BpN/R, 520BpN/R2, 520Bp/R, 520Bp/R2								
0.1-220rpm	0.004-9.0	0.01-23	0.04-92	0.17-370	0.38-830	0.67-1500	1.1-2300	1.5-3300

520R Fluorel (ml/min)					
Speed range	1.6mm	3.2mm	4.8mm	6.4mm	8.0mm
520BpN/R, 520BpN/R2, 520Bp/R, 520Bp/R2					
0.1-220rpm	0.03-70	0.13-280	0.29-630	0.51-1100	0.80-1800

520R Neoprene, Sta-Pure, Chem-Sure, PVC, Pumpsil (USGPH)								
Speed range	0.5mm	0.8mm	1.6mm	3.2mm	4.8mm	6.4mm	8.0mm	9.6mm
520BpN/R, 520BpN/R2, 520Bp/R, 520Bp/R2								
0.1-220rpm	0.0001-0.14	0.0002-0.35	0.001-1.4	0.003-5.6	0.006-13	0.01-22	0.02-35	0.03-50

520R Marprene / Bioprene 64 shore tubing (USGPH)								
Speed range	0.5mm	0.8mm	1.6mm	3.2mm	4.8mm	6.4mm	8.0mm	9.6mm
520BpN/R, 520BpN/R2, 520Bp/R, 520Bp/R2								
0.1-220rpm	0.0001-0.14	0.0002-0.37	0.001-1.5	0.003-5.9	0.01-13	0.01-23	0.02-37	0.02-53

520R Fluorel (USGPH)					
Speed range	1.6mm	3.2mm	4.8mm	6.4mm	8.0mm
520BpN/R, 520BpN/R2, 520Bp/R, 520Bp/R2					
0.1-220rpm	0.0005-1.1	0.002-4.5	0.005-10	0.01-18	0.01-28

Elements

520REL Neoprene, Sta-Pure, Chem-Sure, Pumpsil (ml/min)				520REL Marprene / Bioprene TL (ml/min)		
Speed range	3.2mm	6.4mm	9.6mm	3.2mm	6.4mm	9.6mm
520Bp/REL, 520BpN/REL						
0.1-220rpm	0.18-390	0.70-1500	1.6-3500	0.17-370	0.67-1500	1.5-3300

520REL Neoprene, Sta-Pure, Chem-Sure, Pumpsil (USGPH)				520REL Marprene / Bioprene TL (USGPH)		
Speed range	3.2mm	6.4mm	9.6mm	3.2mm	6.4mm	9.6mm
520Bp/REL, 520BpN/REL						
0.1-220rpm	0.003-6.1	0.01-25	0.03-55	0.003-5.9	0.01-23	0.02-53

520REM Sta-Pure, Chem-Sure (ml/min)			520REM Marprene / Bioprene TM (ml/min)	
Speed range	3.2mm	6.4mm	3.2mm	6.4mm
520Bp/REM, 520BpN/REM				
0.1-220rpm	0.18-390	0.70-1500	0.17-370	0.67-1500

520REM Sta-Pure, Chem-Sure (USGPH)			520REM Marprene / Bioprene TM (USGPH)	
Speed range	3.2mm	6.4mm	3.2mm	6.4mm
520Bp/REM, 520BpN/REM				
0.1-220rpm	0.003-6.1	0.01-25	0.003-5.9	0.01-23

520REH Marprene / Bioprene TH, Sta-Pure (ml/min)		520REH Marprene / Bioprene TH, Sta-Pure (USGPH)
Speed range	3.2mm	3.2mm
520Bp/REH, 520BpN/REH		
0.1-220rpm	0.20-450	0.003-7.1

Performance curves

Marprene continuous tubing, 1.6mm wall, 200rpm, clockwise rotation

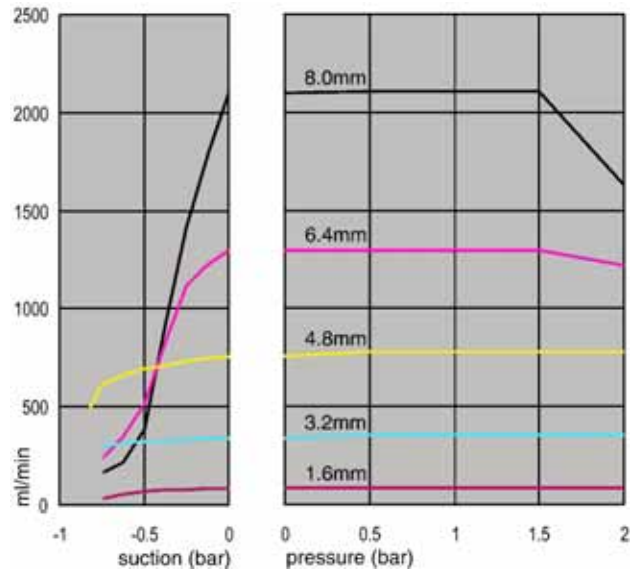

Marprene continuous tubing, 1.6mm wall, 200rpm, counter-clockwise rotation

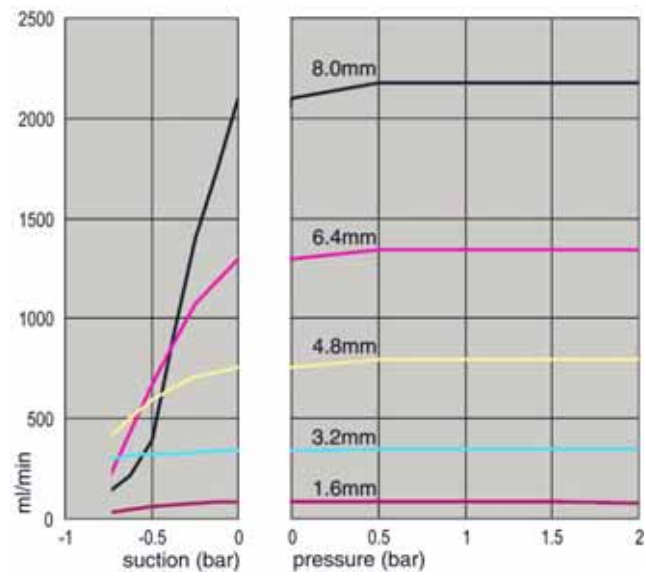

Marprene continuous tubing, 2.4mm wall, 200rpm, clockwise rotation

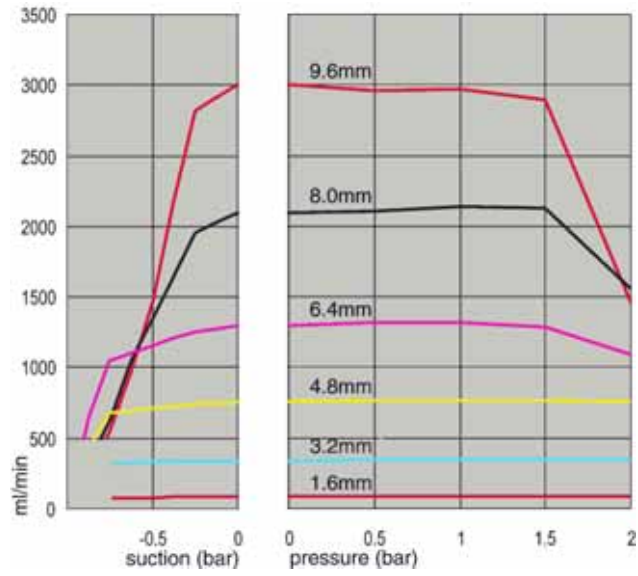

Marprene continuous tubing, 2.4mm wall, 200rpm, counter-clockwise rotation

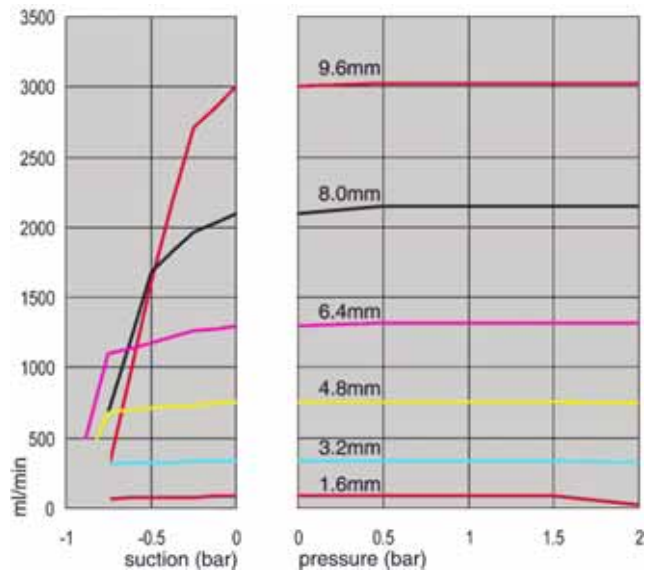

Marprene TL element, 0-2 bar (0-30psi), 200rpm, counter-clockwise rotation

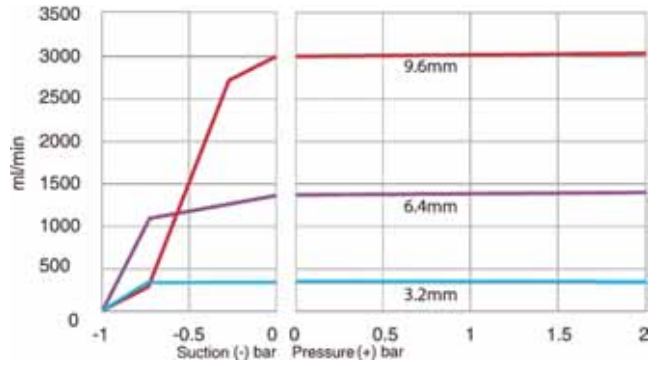

Sta-Pure element, 0-2 bar (0-30psi), 200rpm, counter-clockwise rotation

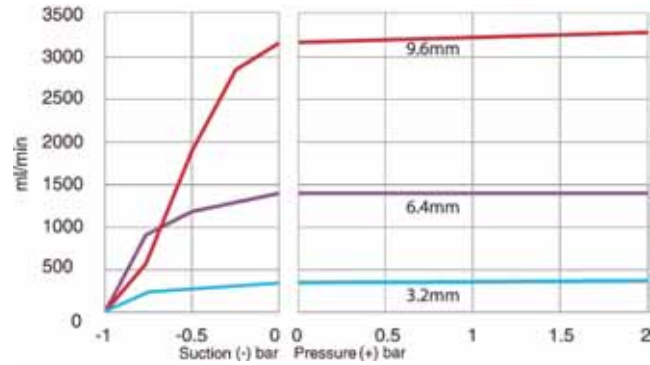

Marprene TM element, 2-4 bar (30-60psi), 200rpm, counter-clockwise rotation

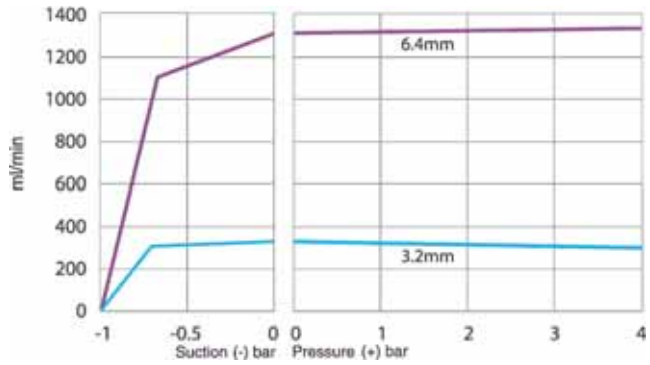

Sta-Pure element, 2-4 bar (30-60psi), 200rpm, counter-clockwise rotation

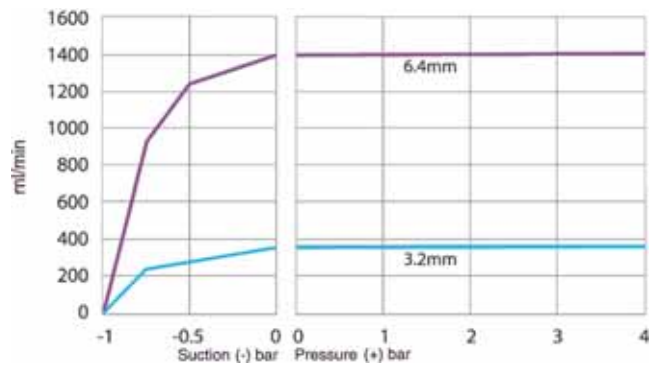

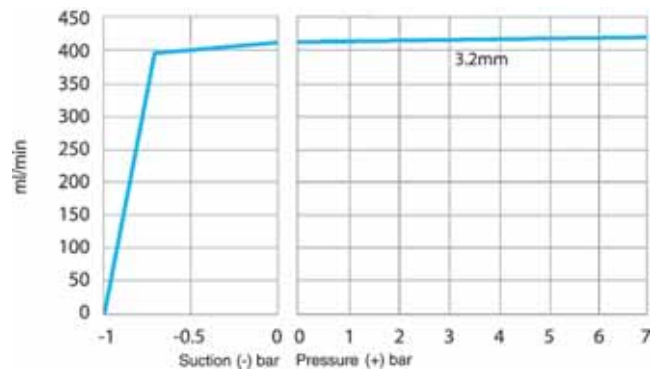

Marprene TH element, 4-7 bar (60-100psi), 200rpm, counter-clockwise rotation





40 520R, 520R2 and 520RE tubing and element part numbers

1.6mm wall tubing for 520R pumpheads

					
mm	inch	#	Marprene	Bioprene	Chem-Sure
0.5	$\frac{1}{50}$	112	902.0005.016	903.0005.016	
0.8	$\frac{1}{32}$	13	902.0008.016	903.0008.016	
1.6	$\frac{1}{16}$	14	902.0016.016	903.0016.016	965.0016.016
3.2	$\frac{1}{8}$	16	902.0032.016	903.0032.016	965.0032.016
4.8	$\frac{3}{16}$	25	902.0048.016	903.0048.016	965.0048.016
6.4	$\frac{1}{4}$	17	902.0064.016	903.0064.016	965.0064.016
8.0	$\frac{5}{16}$	18	902.0080.016	903.0080.016	965.0080.016
mm	inch	#	PVC	Fluorel	Neoprene
0.8	$\frac{1}{32}$	13			920.0008.016
1.6	$\frac{1}{16}$	14	950.0016.016	970.0016.016	920.0016.016
3.2	$\frac{1}{8}$	16	950.0032.016	970.0032.016	920.0032.016
4.8	$\frac{3}{16}$	25	950.0048.016	970.0048.016	920.0048.016
6.4	$\frac{1}{4}$	17	950.0064.016	970.0064.016	920.0064.016
8.0	$\frac{5}{16}$	18	950.0080.016	970.0080.016	920.0080.016
mm	inch	#	Pumpsil	Sta-Pure	
0.5	$\frac{1}{50}$	112	913.A005.016		
0.8	$\frac{1}{32}$	13	913.A008.016		
1.6	$\frac{1}{16}$	14	913.A016.016	960.0016.016	
3.2	$\frac{1}{8}$	16	913.A032.016	960.0032.016	
4.8	$\frac{3}{16}$	25	913.A048.016	960.0048.016	
6.4	$\frac{1}{4}$	17	913.A064.016	960.0064.016	
8.0	$\frac{5}{16}$	18	913.A080.016	960.0080.016	

Note: 1.6mm wall Chem-Sure and Sta-Pure tubing are supplied in 305mm lengths.

2.4mm wall tubing for 520R2 pumpheads

					
mm	inch	#	Marprene	Bioprene	Pumpsil
0.5	1/50				913.A005.024
0.8	1/32				913.A008.024
1.6	1/16	119	902.0016.024	903.0016.024	913.A016.024
3.2	1/8	120	902.0032.024	903.0032.024	913.A032.024
4.8	3/16	15	902.0048.024	903.0048.024	913.A048.024
6.4	1/4	24	902.0064.024	903.0064.024	913.A064.024
8.0	5/16	121	902.0080.024	903.0080.024	913.A080.024
9.6	3/8	122	902.0096.024	903.0096.024	913.A096.024
mm	inch	#	Chem-Sure	Sta-Pure	
0.8	1/32				
1.6	1/16	119	965.0016.024	960.0016.024	
3.2	1/8	120	965.0032.024	960.0032.024	
4.8	3/16	15	965.0048.024	960.0048.024	
6.4	1/4	24	965.0064.024	960.0064.024	
8.0	5/16	121	965.0080.024	960.0080.024	
<i>Note: 2.4mm wall Chem-Sure and Sta-Pure tubing are supplied in 355mm lengths.</i>					

2.4mm wall elements for 520RE pumpheads

0-2 bar (0-30 psi) pressure rated elements



Industrial

mm	inch	#	Marpren TL	Pumpsil	Neoprene	Chem-Sure
3.2	1/8	16	902.0032.PFQ	913.A032.PFQ	920.0032.PFQ	965.0032.PFQ
6.4	1/4	17	902.0064.PFQ	913.A064.PFQ	920.0064.PFQ	965.0064.PFQ
9.6	3/8	122	902.0096.PFQ	913.A096.PFQ	920.0096.PFQ	965.0096.PFQ

Sanitary

mm	inch	#	Bioprene TL	Pumpsil	Sta-Pure	Chem-Sure
3.2	1/8	16	903.0032.PFT	913.A032.PFT	960.0032.PFT	965.0032.PFT
6.4	1/4	17	903.0064.PFT	913.A064.PFT	960.0064.PFT	965.0064.PFT
9.6	3/8	122	903.0096.PFT	913.A096.PFT	960.0096.PFT	965.0096.PFT

2-4 bar (30-60 psi) pressure rated elements



Industrial

mm	inch	#	Marpren TM	Chem-Sure
3.2	1/8	16	902.P032.PFQ	965.M032.PFQ
6.4	1/4	17	902.P064.PFQ	965.M064.PFQ

Sanitary

mm	inch	#	Biopren TM	Sta-Pure
3.2	1/8	16	903.P032.PFT	960.M032.PFT
6.4	1/4	17	903.P064.PFT	960.M064.PFT

4-7 bar (60-100 psi) pressure rated elements



Industrial

mm	inch	#	Marpren TM	Sta-Pure
3.2	1/8	16	902.H032.PFQ	960.H032.PFQ

Sanitary

mm	inch	#	Biopren TM	Sta-Pure
3.2	1/8	16	903.H032.PFT	960.H032.PFT

41 520 series pumping accessories

Accessory	Description	Part code	Pump compatibility
520ANC	Network cable, RS232, with 9-pin D-connectors	059.3121.000	520Du, 520Di
520ANX	Network extension cable with 9-pin D-connectors	059.3122.000	520Du, 520Di
520ANA	Network adaptor, 25-pin to 9-pin D-connectors	059.3123.000	
520AB	Batch records cable with 9-pin D-connectors	059.3125.000	520Di
520AF	Footswitch with 25-pin D-connector	059.3002.000	520U, 520Du, 520Di
520AH	Handswitch with 25-pin D-connector	059.3022.000	520U, 520Du, 520Di
520AV	Proximity switch	059.5072.000	520Di
520AVN	Proximity switch	059.507N.000	520DiN
505LTC	Tube clamp set for 505L pumphead	059.4001.000	520Di
505AS	Filling stand	059.5001.000	All models
520AL	Dispensing lance for use with 520AFN filling needles	059.5052.000	All models
505AFN	Filling needle set	059.5101.000	All models
	Filling needle 1.6mm bore	059.5100.016	All models
	Filling needle 3.2mm bore	059.5100.032	All models
	Filling needle 4.8mm bore	059.5100.048	All models
	Filling needle 6.4mm bore	059.5100.064	All models
	Filling needle 8.0mm bore	059.5100.080	All models
	Tube monitor with 25-pin D-connector	059.4501.520	520U, 520Du, 520Di
	Tube monitor, bare lead	059.450N.520	520UN, 520DuN, 520DiN
520AD	Leak detector kit	059.8131.000	520UN, 520DuN, 520DiN

BpN, Bp

42 Trademarks

Watson-Marlow, Bioprene, Pumpsil, LoadSure and **Marprene** are trademarks of Watson-Marlow Limited.

Fluorel is a trademark of 3M.

Sta-Pure and **Chem-Sure** are trademarks of W.L.Gore and Associates.

BpN, Bp

43 Warning not to use pumps in patient-connected applications

Warning These products are not designed for use in, and should not be used for patient-connected applications.

BpN, Bp

44 Publication history

m-520bpn-bp-gb-01.qxp: Watson-Marlow 520BpN and 520Bp

First published 09 08.

45 Decontamination certificate

In compliance with the *UK Health and Safety at Work Act* and the *Control of Substances Hazardous to Health Regulations*, you are required to declare the substances which have been in contact with product(s) you return to Watson-Marlow or its subsidiaries or distributors. Failure to do so will cause delays. Please ensure that you fax us this form and receive an RGA (Returned Goods Authorisation) before you despatch the product(s). A copy of this form must be attached to the outside of the packaging containing the product(s). Please complete a separate decontamination certificate for each product.

You are responsible for cleaning and decontaminating the product(s) before return.

Your name	<input type="text"/>	Company	<input type="text"/>
Address	<input type="text"/>		
Postcode/zip	<input type="text"/>	Country	<input type="text"/>
Telephone	<input type="text"/>	Fax	<input type="text"/>
Product type	<input type="text"/>	Serial number	<input type="text"/>
To speed the repair, please describe all known faults	<input type="text"/>		
The product has ...	<input type="checkbox"/> Been used <input type="checkbox"/> Not been used		
	<i>If the product has been used, please complete all the following sections. If the product has not been used, please just sign this form.</i>		
Names of chemicals handled with product(s)	<input type="text"/>		
Precautions to be taken in handling these chemicals	<input type="text"/>		
Action to be taken in the event of human contact	<input type="text"/>		
	<i>I understand that the personal data collected will be kept confidentially in accordance with the UK Data Protection Act 1998.</i>		
Signature	<input type="text"/>	RGA number	<input type="text"/>
		Your position	<input type="text"/>
		Date	<input type="text"/>
	<i>Please print out, sign and fax to Watson-Marlow Pumps at +44 1326 376009.</i>		