

# OPERATING INSTRUCTIONS

## MHRE Mk. 4 Flow Inducer

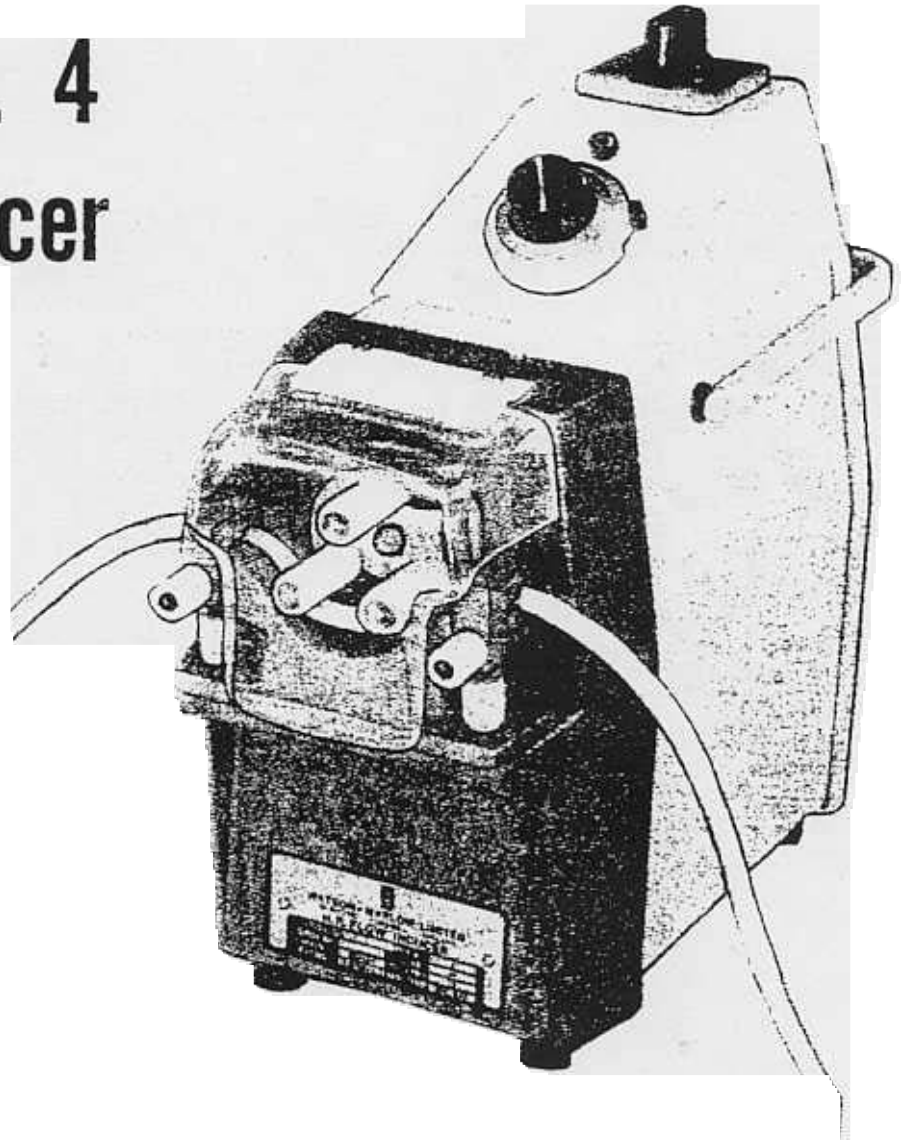

**WATSON-MARLOW LIMITED**

FALMOUTH, CORNWALL, ENGLAND, TR11 4RU.

Telephone: PENRYN (STD 0326) 73461

Telex: 45594 Triflo G

Publication No. MEO 9

Publication Date: 1.9.78

# GENERAL CONTENTS

		PAGE
	INTRODUCTION	1
SECTION 1	HEALTH & SAFETY	1
SECTION 2	TECHNICAL INFORMATION	2
2.1	Flow Data	2
2.2	Weights and Dimensions	2
SECTION 3	INSTALLATION and ELECTRICAL CONNECTIONS	3
3.1	Electrical Connections -- General	3
3.2	Fuse Protection	3
3.3	Voltage	4
3.4	Voltage Change	4
3.5	Direction Control	4
3.6	Speed Control	4
SECTION 4	OPERATION	8
4.1	Inserting a Tube in a Track	8
4.2	Adjusting Tube 'Squeeze'	9
4.3	Starting	9
SECTION 5	TRACKS	9
5.1	Twin Tube Clip Tracks	9
5.2	Metal Clamp Tracks	9
SECTION 6	TUBING	10
6.1	Tube Selection	10
SECTION 7	LUBRICATION	10
7.1	General Lubrication	10
7.2	Tubing Lubrication	10
	CIRCUIT DIAGRAMS	
	MHRE/200, MHRE/100 and MHRE/7	11
	MHRE/22 and MHRE/2	12

## INTRODUCTION

The MHRE Flow Inducers are compactly designed. All are mounted on cushioned feet and are free standing on any surface. The unique design of the MHRE Flow Inducer enables each model in the range to work on a wide variety of tube bore sizes without modification.

Operating details are identical for all units.

## Section 1 HEALTH & SAFETY

It is advisable before connecting any Watson-Marlow Flow Inducer users familiarise themselves with the Operating Instructions, paying particular attention to the following sections:-

Section	3	3.1
		3.1.1
		3.2
		3.3
		3.3.1
		3.5
- Section	4	4.1
		4.1.1
		4.3

## 2.1 Flow Data

Different models of the MHRE Mk.4 Flow Inducer are identified by a numerical suffix the value of which gives the maximum rotor speed. The minimum speed with full torque is about 1/25 of the maximum in each case.

Flow rate is proportional to the bore size of the tube and the rotor speed. All MHRE models will accept tubes 1.6 mm (1/16") wall thickness and up to 8.0 mm (5/16") bore.

The following flow rates are obtainable with Silicone tubing pumping water at a nominal head and approximately 20°C ambient, at r.p.m. indicated by the model suffix figure. They are for guidance and comparison only. Actual flow rates may vary due to viscosity, adverse suction conditions or tubing materials required. Watson-Marlow will gladly advise on flow rates under specified conditions.

Bore size of tube		Max. flow in ml / min				
		MHRE 200	MHRE 100	MHRE 22	MHRE 7	MHRE 2
mm	in					
0.5	1/50	8.5	4.25	0.9	0.27	0.08
0.8	1/32	15.5	7.50	1.5	0.45	0.14
1.6	1/16	48.5	24.4	5.2	1.50	0.45
3.2	1/8	200	100	23	6.20	1.85
4.8	3/16	368	180	40	11.0	3.20
6.4	1/4	548	264	58	16.3	4.50
8.0	5/16	830	390	85	22	7

Minimum Flow Rate will be about 1/25 of the maximum in each case.

## 2.2 Weights and Dimensions

	Length	Height	Width	Weight
MHRE/200	292 mm	292 mm	135 mm	7 kg
MHRE/100	292 mm	292 mm	135 mm	7 kg
MHRE/22	292 mm	292 mm	135 mm	7 kg
MHRE/7	380 mm	292 mm	135 mm	8 kg
MHRE/2	380 mm	292 mm	135 mm	8 kg

**3.1      Electrical Connections      General**

Check that the voltage stamped on the identity plate corresponds to the local supply.

*Mains Lead to Plug Connections*

**WARNING – THIS APPLIANCE MUST BE EARTHED**

The MHRE Mk.4 Flow Inducers are supplied with a 3 metre (9 feet) length of 3-core cable.

**I M P O R T A N T**

The wires in the mains lead are coloured in accordance with the following code:-

Green - and - Yellow	Earth
Blue	Neutral
Brown	Live

As the colours of the wires in the mains lead of the appliance may not correspond with the coloured marking identifying the terminals in your plug, proceed as follows:-

The wire which is coloured green-and-yellow must be connected to the terminal in the plug which is marked with the letter 'E' or by the earth symbol  $\perp$  or coloured green or green-and-yellow.

The wire which is coloured blue must be connected to the terminal which is marked with the letter 'N' or coloured black (or blue).

The wire which is coloured brown must be connected to the terminal which is marked with the letter 'L' or coloured red (or brown).

**3.2      'Power On' Indicator**

The MHRE Mk. 4 is fitted with a green 'POWER ON' indicator in the transformer secondary low tension circuit, which illuminates when the unit is connected to the mains supply, the three position direction switch is in one of the two 'ON' positions and the fusing intact.

**THIS INDICATOR IS NOT A FAIL-SAFE DEVICE.**

**Fuse Protection**

MHRE Flow Inducers are protected by a 1.0 Amp fuse fitted in series with the live conductor of the mains cable. A 1.25 Amp fuse safeguards the motor and control circuits. Both fuses are of the cartridge type and are located at the rear of the unit.

If a fuse should require replacement – a sign the motor has been overloaded:-

**NEVER REPLACE A FUSE BY ONE HIGHER THAN THE SPECIFIED RATED VALUE.**

**REPEATED FUSE FAILURE INDICATES A FAULT CONDITION.**

### 3.4 Voltage

MHRE Mk.4 Flow Inducers are suitable for operation on single-phase mains supplies, normally either 110/115 volt or 200/250 volt 50 Hz. The operating voltage is indicated on the name plate and is normally 200/250 volts.

### 3.5 Voltage Change

To change the voltage from that stated on the name plate, remove plug or disconnect the unit from the mains, undo the 4 domed nuts and remove back cover. Make the connection to the terminal block on the printed circuit board as indicated in the following diagram.

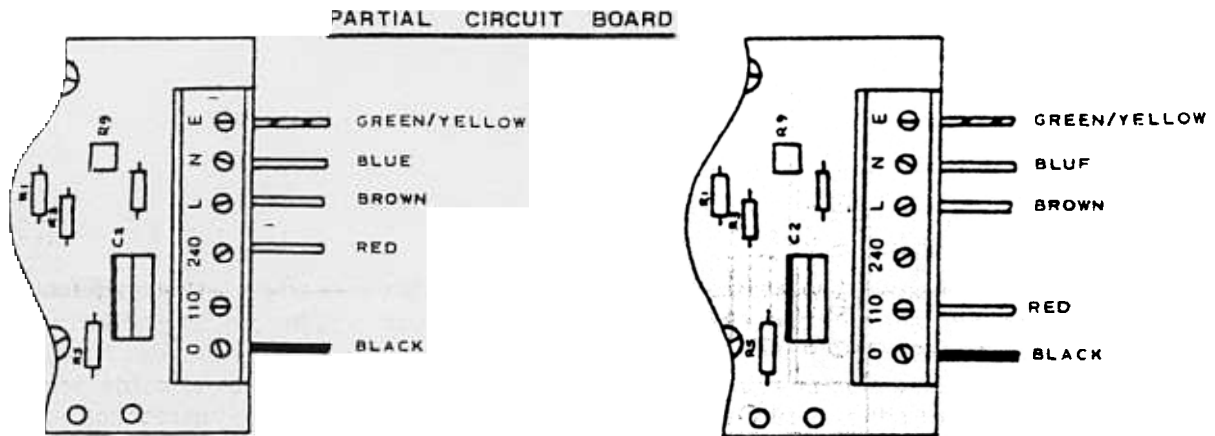

Connection for 200/250V a.c. operation

Connection for 110/115V a.c. operation

### 3.6 Direction Control

The MHRE Mk.4 Flow Inducer is a reversible pump. It is controlled by a three position switch, the centre position is OFF and flow takes place in the direction to which the arrow on the switch knob is pointed.

#### 3.6.1. Uni-Directional Stop Plate (Optional Extra)

This device may be fitted to any MHRE Flow Inducer in order to prevent the accidental reversal of flow. It will allow the switch to be turned only one way. In case of emergency, the plastic flap may be lifted enabling the switch to be turned in either direction.

To change permitted direction of switching, remove the screws, invert the flap and replace the screws.

### 3.7 Speed Control

MHRE Mk.4 Flow Inducers are provided with two separate coloured plugs at the rear of the unit.

The speed of rotation may be varied manually from standstill to full speed. Automatic speed control within a range of 25:1 ensures constant flow rate despite mains voltage, temperature and load torque variations within normally occurring limits.



**RED PLUG PERMANENT PIN CONNECTIONS**

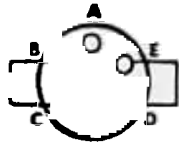

When manual control is required the RED plug must be fitted in the socket at the rear of the unit and fixed securely in position with the threaded locking collar. The plug is already fitted with links on terminals DE and BC as shown in the Circuit Diagrams on page 11 and 12. When this plug is in position the speed of the flow inducer can be varied by

rotation of the multi-turn numerical indicator knob, and the direction can be altered as shown on the ON-OFF-ON flow switch. The RED plug connections are shown in the following schematic:-

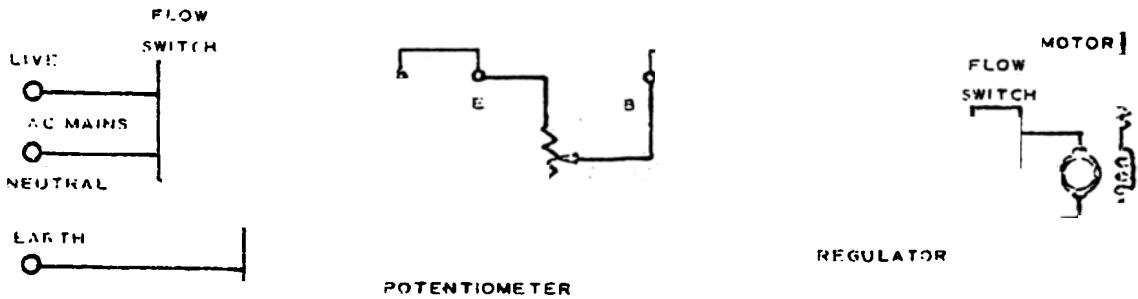

Automatic Control using the YELLOW Plug

The YELLOW plug is provided without any terminal links but can be connected as appropriate to any of the following applications. The RED plug must be removed and replaced by the YELLOW plug when the required connections have been made.

**NOTE:** TERMINAL 'A' EARTH CONNECTION IS PERMANENTLY MADE IN FLOW INDUCER. EXTERNAL CONNECTIONS TO PIN 'A' WILL AUTOMATICALLY BE EARTHED.

a)

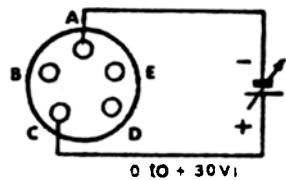

In this application the multi-turn numerical indicator knob is disabled but speed control is achieved by variation of the injected D.C. voltage. Direction of flow can be altered by means of the flow switch being set to the required position.

The YELLOW plug connections for this application are shown in the following schematic:-

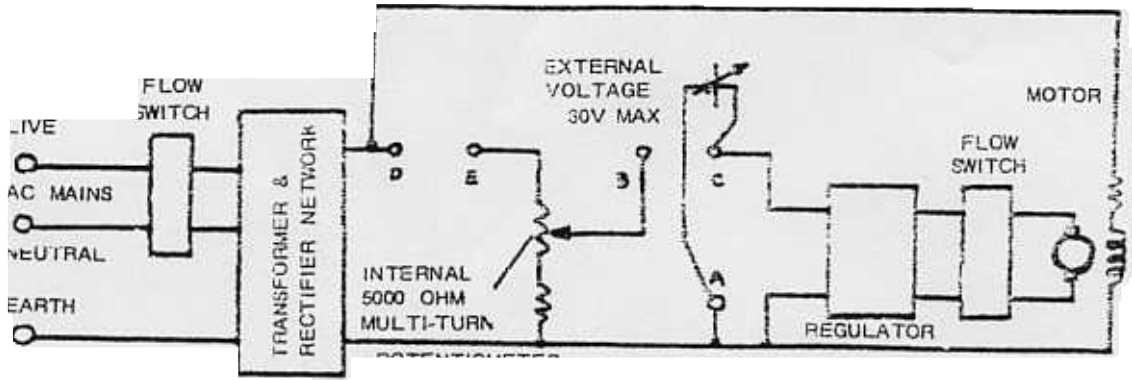

b) Remote Potentiometer Control

Connect the YELLOW plug pins as follows:-

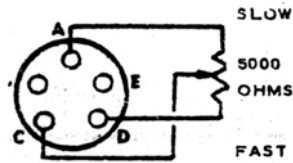

- A. to counter clockwise end of External 5000 ohms potentiometer.
- B. no connection.
- C. to Wiper of External 5000 ohms potentiometer.
- D. to clockwise end of the External 5000 ohms potentiometer.
- E. no connection.

It is recommended that a multi-turn 5000 ohm wire-wound Potentiometer should be used.

In this application the multi-turn numerical indicator knob is disabled but speed control is achieved by variation of the External 5000 ohms Potentiometer. Direction of flow can be altered by means of the flow switch being set to the required position.

The YELLOW plug connections for this application are shown in the following schematic:-

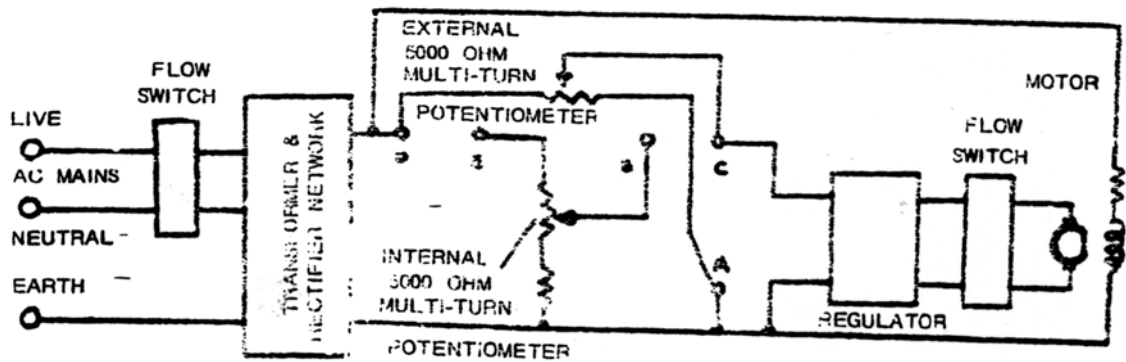



c) Control by injected 'Floating' D.C. Voltage with manually set mean speed

Connect the YELLOW plug as follows:-

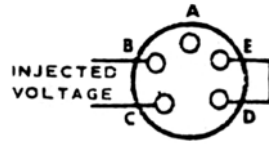

- A. normally no connection - but can be used as Earth reference for external circuitry.
- B. connect to appropriate injected voltage terminal.
- C. connect to appropriate injected voltage terminal.
- D. link together.
- E. link together.

In this application the flow inducer may be controlled by a 'Floating' or isolated control voltage  $V_C$  superimposed upon an internally generated voltage  $V_i$ . The internal voltage  $V_i$  is set by manual adjustment of the numerical indicator knob to give a particular speed of rotation when  $V_C$  is zero. Thus when  $V_C$  varies the speed of rotation will vary accordingly. This method of control is particularly appropriate if  $V_C$  is derived from a transducer producing zero output at zero deviation.

**NOTE** The combined sum of  $V_i$  and  $V_C$  should not exceed +30V.

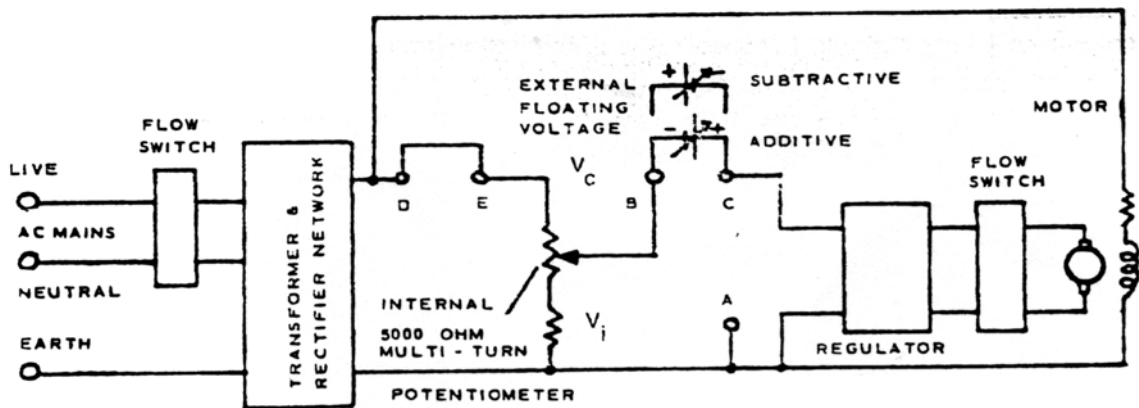

**4.1      Inserting an Elastic Tube**

Switch off Flow Inducer before lifting the guard.

Fitting a tube in a Watson-Marlow Flow Inducer is a straightforward procedure requiring no specialised knowledge or expertise. The procedure is the same for all models and is described at length for clarity, but in practice the operation can be done in a minute or two.

**4.1.1      Tube - Clip Tracks**

- a. Switch on the Flow Inducer and stop it when one of the rollers is directly below the rotor centre.
- b. **SWITCH OFF FLOW INDUCER BEFORE LIFTING GUARD.**
- c. Remove the track from the base by slackening both thumb nuts and withdrawing it from the tapered base.
- d. Completely unscrew the two thumb nuts on the track. Select a pair of tube-clips large enough to fit comfortably round the tubing to be used and slip one over each stud by the *circular* hole end, leaving the open ends (with elongated holes) facing outwards from the track.
- e. Lay the tubing inside the clips and close these by passing the *elongated* slots over the tube-clip studs and screwing up the thumb nuts loosely. Secure the tube at one end by pressing down hard vertically on the tube engaging the teeth on the touching faces of the clip, preventing it from slipping.
- f. Arrange the tube to lie in a shallow dip in the track between the tube-clips and lightly close the second clip.
- g. Hold the free end of the tube in one hand and press down on the centre of the tube between the clips with the thumb of the other hand. Allow the free end of the tube *under tension* to slip through the hand until the tube is stretched just sufficiently to make it touch the centre of the track curve.
- h. Secure the second tube-clip by pressing down on the clip and tightening the thumb nut, keeping the tube in position until firmly gripped.
- j. Tilt the tube track forward, i.e. with the top towards the flow inducer, and position the tube under the bottom roller. Now straighten up the track and slide it fully up the tapered base and tighten in this position by means of the two thumb nuts.
- k. Replace the guard before switching on the Flow Inducer.

**NOTE**

When the tube is in position it will be stretched slightly by the moving rollers, and by this means the tube is prevented from moving sideways off the track. However, should a sideways movement occur, more tension should be applied to the tube. To do this, slacken off one of the tube-clips, gently pull the tube a little tighter and re-tighten the tube-clip.

## Adjusting Tube 'Squeeze'

Adjustment of the pressure of the rollers on the tube is made by sliding the track up or down its tapered base. With the track pushed up as far as possible the tube will be completely closed between the rollers and the track curve (providing the tubing is of the correct wall thickness), making the action one of positive displacement. This position is the best for creating a vacuum or priming a dry tube. Moving the track should be done with both hands to keep the track parallel on its tapered base and this can be done whilst the Flow Inducer is running, but only with *extreme care*.

Once primed, the track can be withdrawn slightly down the incline, thus increasing the clearance. In this position back-slip can occur and the flow inducer can be operated against a restricted or closed outlet without building up excessive pressure, and at the same time prolonging the life of the tube. Remember to tighten the track thumb nuts.

## Starting

Ensure that the guard is correctly positioned before starting.

MHRE models may be started at any speed setting and the setting may be altered with the pump either running or stationary.

## Section 5 TRACKS

### 5.1 Twin Tube Clip Tracks

These tracks are similar in basic design to the standard tube-clip track with facilities for accommodating two tubes. The technique of fitting the tubes is described in Section 4.

### 5.2 Metal Clamp Tracks

#### 5.2.1 Single Clamp Tracks

This type of track can be supplied to any bore size of tube up to 8.0 mm (5/16") maximum.

SINGLE  
CLAMP  
TRACK

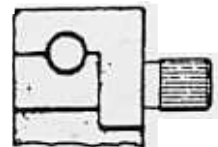

#### Double Clamp Track

This type of track is designed for single or double-tube operation using two tubes or identical bore sizes. It can be supplied to any specified bore up to 4.8 mm (3/16") maximum.

e.g. Two 4.8 mm (3/16") bore tubes,  
1.6 mm (1/16") wall thickness.

DOUBLE  
CLAMP  
TRACK

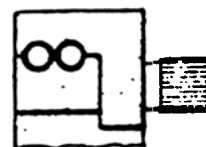

### 5.2.3 Split Clamp Track

This type of track is designed for single or double-tube operation using two tubes of dissimilar bore size. It can be supplied to any specified bore up to 4.8 mm (3/16") maximum for the larger tube.

e.g. One 0.5 mm (1/50") tube and the other 4.8 mm (3/16") bore, both of 1.6 mm (1/16") wall thickness, in parallel.

SPLIT  
CLAMP  
TRACK

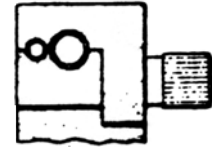

## Section 6 TUBING

### 6.1 Tube Selection

Tubing is available from Watson-Marlow Limited in Neoprene, Butyl Rubber, Silicone Rubber, Elastic P.V.C. and Viton. Advice will always be given as to the best tubing for a particular application.

Sizes:-	0.5 mm	0.8 mm (1/32")	1.6 mm (1/16")
		3.2 mm (1/8")	4.8 mm (3/16")
		6.4 mm (1/4")	8.0 mm (5/16")

Wall thickness is 1.6 mm (1/16") except for Viton which is 0.8 mm (1/32"). Special Rollers are required with the thinner wall Viton tube. These rollers are supplied with Flow Inducers originally purchased for use with Viton tubing but may be obtained as replacement spares on request from Watson-Marlow Limited (Part Number for roller - 1 - 53).

## Section 7 LUBRICATION

### 7.1 General Lubrication

Lightly lubricate the rollers and spindle occasionally.

### 7.2 Tubing Lubrication

External lubrication of tubes may assist in increasing the tube life. Silicone grease (Midland Silicone MS4 or similar) can be used on all materials except Silicone Rubber. Glycerine and other non-solvent lubricants can be applied to Silicone Rubber and other Elastomers.

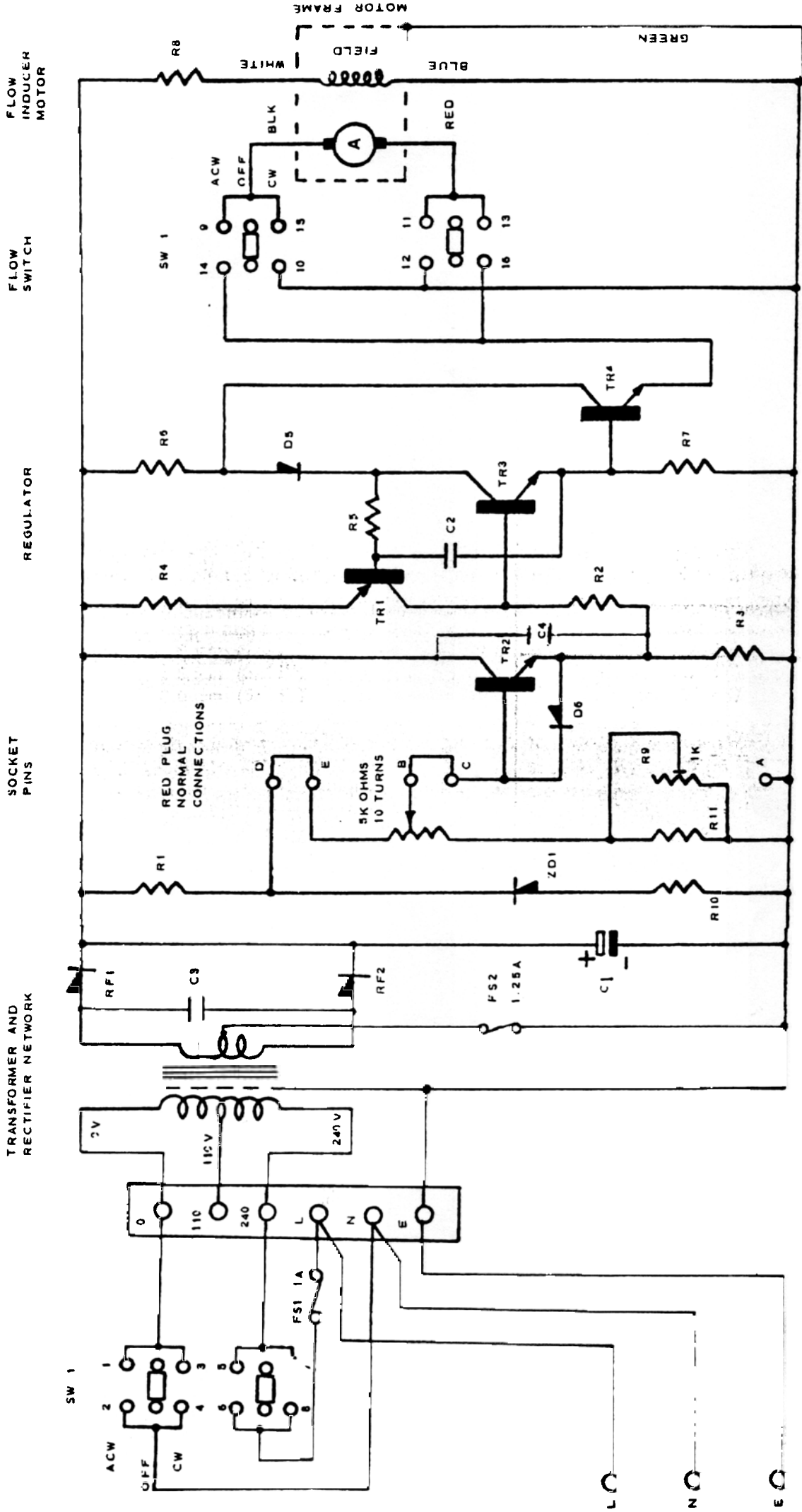

MHRE Mk. 3 FLOW INDUCER  
 Circuit Diagram for MHRE/200, MHRE/100 and MHRE/7

From Serial Number:- 49590