

Publication PB 0188
Issue 2

Watson-Marlow high flow, high pressure pump
Installation and operating instructions

Pumphead/s:	919 Issue 1
	925 Issue 1
	940 Issue 1
	945 Issue 1

900 series



Contents

Declarations	Page 2
Safety	Page 3
Information for returning pumps	Page 3
Two year warranty	Page 3
Recommended operating procedures	Page 4
Part 1: Installation	
Siting	Page 5
Pump connections	Page 5
Electrical connection	Page 6
Powered tube removal	Page 7
Powered tube fitting	Page 8
Manual tube removal	Page 9
Manual tube fitting	Page 10
Shoe adjustment	Page 13
Part 2: Operation	
Flow rates	Page 14
Part 3: Appendices	
Spares	Page 16
Materials of construction	Page 18
Specification	Page 18
Outline drawing	Page 19
Decontamination certificate	Page 20

Declarations

Declaration of conformity



When a 900 series drive unit, fitted with the 900 series pumphead is used as a stand alone pump it complies with:

Machinery Directive 89/392/EEC EN60204-1

Low Voltage Directive 73/23/EEC EN61010-1

EMC Directive 89/336/EEC EN50081-1/50082-1

Responsible person: A S Balding, Managing Director, Watson-Marlow Limited, Falmouth, Cornwall TR11 4RU, England.

Telephone 01326 370370 Fax 01326 376009

Declaration of incorporation

When the 900 series pumphead is to be installed into machines or assembled with other machines for installations, it must not be put into service until the relevant machinery has been declared in conformity with the provisions of the machinery directive 89/392/EEC and EN60204-1.

Responsible person: A S Balding, Managing Director, Watson-Marlow Limited, Falmouth, Cornwall TR11 4RU, England.

Telephone 01326 370370 Fax 01326 376009

Safety

In the interests of safety, this pump and the tubing selected should only be used by competent, suitably trained personnel after they have read and understood this manual, and considered any hazard involved.



Any person who is involved in the installation or maintenance of this equipment should be fully competent to carry out the work. In the UK this person should also be familiar with the Health and Safety at Work Act 1974.

Do not remove or open pumphead door whilst operating pump.

Do not place fingers inside pumphead.

Ensure the drive is inoperative before opening the pumphead door.

There are dangerous voltages (at mains potential) inside the motor. If access is required, isolate the motor from the mains before removing the terminal box cover.

Information for returning pumps

Any equipment which has been contaminated with, or exposed to, body fluids, toxic chemicals or any other substance hazardous to health must be decontaminated before it is returned to Watson-Marlow or its distributor.

A certificate (a suitable blank form is included at the rear of these operating instructions), or signed statement, must be attached to the outside of the shipping carton.

This certificate is required even if the pump is unused. If the pump has been used, the fluids that have been in contact with the pump and the cleaning procedure must be specified along with a statement that the equipment has been decontaminated.

Two year warranty

Watson-Marlow Limited warrants, subject to the conditions below, through either Watson-Marlow Limited, its subsidiaries, or its authorised distributors, to repair or replace free of charge, including labour, any part of this product which fails within two years of delivery of the product to the end user. Such failure must have occurred because of defect in material or workmanship and not as a result of operation of the product other than in accordance with the instructions given in this manual.

Conditions of and specific exceptions to the above warranty are:

- Consumable items such as **tubing and glands** are excluded.
- Products must be returned by pre-arrangement carriage paid to Watson-Marlow Limited, its subsidiaries, or its authorised distributor.
- All repairs or modifications must have been made by Watson-Marlow Limited, its subsidiaries, or its authorised distributors or with the express permission of Watson-Marlow Limited, its subsidiaries, or its authorised distributors.
- Products which have been abused, misused, or subjected to malicious or accidental damage or electrical surge are excluded.

Warranties purporting to be on behalf of Watson-Marlow Limited made by any person, including representatives of Watson-Marlow Limited, its subsidiaries, or its distributors, which do not accord with the terms of this warranty shall not be binding upon Watson-Marlow Limited unless expressly approved in writing by a Director or Manager of Watson-Marlow Limited.

Recommended operating procedures

DO keep delivery and suction lines as short as possible.

DO use the minimum number of bends in rigid pipe runs. If there must be a bend, use a swept bend and not a tight elbow.

DO use suction and delivery pipelines with a bore equal to or larger than the bore of the tube fitted in the pumphead. When pumping **viscous** fluids, the losses caused by increased friction can be overcome by using pipe runs with a cross sectional area several times greater than the pumping element.

DO run at a slow speed when pumping viscous fluids.

DO keep the track and sliding shoe clean.

DO ensure that the correct type and volume of coolant/lubricant is used.

DO NOT fit valves in the suction or delivery line without considering that peristaltic pumps are self priming and will hold their prime up to several metres, so there may be no need for non-return or foot valves, nor for the loading valves required on many other kinds of pumps.

Any valves fitted must cause no restriction. If electrically actuated valves are fitted, they should be interlocked so that the pump will only run when the valves are open. Fit an automatic by-pass if manual valves are installed.

Explosion proof motors should not be used in an environment where an explosive gas-air mixture is continuously present or present for long periods.

DO NOT connect door switches or any other switch gear with an explosion proof motor.

The temperature of any part or surface of an explosion proof motor must always remain below the ignition temperature of the gas-air mixture it is operating in.

The connector elbow located at the top of the pump head, enables the pump head to be drained of lubricant or any other substance in the case of tube failure.



If the motor/gearbox used with this 900 series pumphead is not supplied directly by Watson-Marlow, it is important to refer to the maintenance manual supplied with the specific motor/gearbox.

Part 1: Installation

Siting

If the pump is to be lifted ensure that all standard rigging practices are adhered to. This procedure should only be carried out by qualified personnel only who are familiar with the Health and Safety at Work Act 1974.



The pump should be situated on a flat horizontal surface where there is free air to circulate around it. Where the tubing is entering and leaving the pumphead there should be least 1m of tube without a bend, a removable drop out section to aid tube replacement, and if practical, this should be of a larger diameter than the pump tubing.

Pump connections

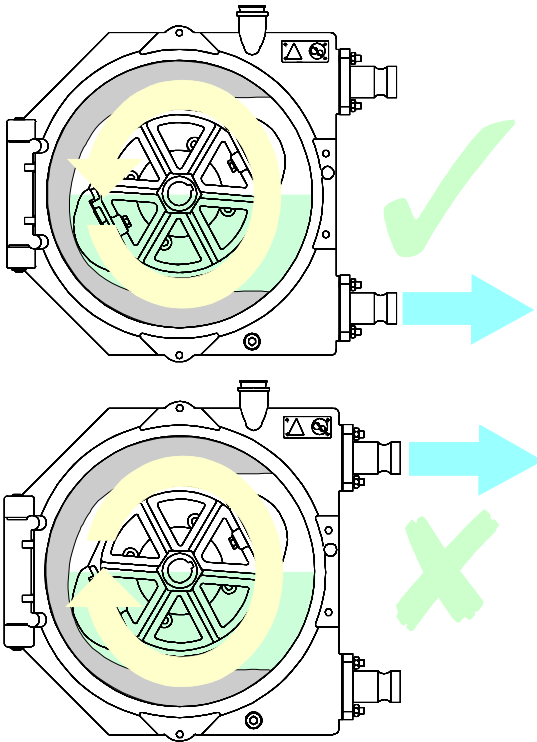

It is recommended that for maximum tube life, the pump should always be set up with the delivery end of the tubing connected to the lower casing port of the pumphead and immersed in cooling lubricant.

This may require the pump head to be re-fitted to the correct orientation for operation.

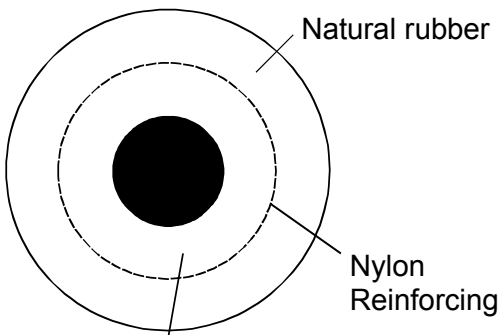

Natural rubber
Food grade natural rubber
Food grade nitrile rubber
Neoprene rubber
EPDM

If the main pipe run to the pump is rigid pipe work, there should be a drop out section or flexible pipe work to allow the pump tubing to be inserted and withdrawn.

For working pressures over 7 bar, always fit an outlet pulsation damper. Watson-Marlow, or its representative, can supply pulsation dampers and will assist with determining the type required for your application.

900 Series tubing is available in the combinations seen left for a range of process requirements.

Electrical connection

In order to effectively protect the motor from overloads, appropriate motor protection devices must be used. Motors fitted to the Watson-Marlow series of pumps are manufactured with a motor temperature cut-out, but a current overload relay should also be fitted to a contact breaker.



The motor should be connected by a qualified engineer who is conversant with the appropriate regulations and they should ensure that the voltage and frequency of the electrical supply corresponds with the data on the motor plate.

Connect the motor in accordance with the wiring diagram which will be found in the motor terminal box.

When a motor thermal protection switch is fitted in the motor, the leads will be found in the motor terminal box. They should be connected to stop the pump if the switch operates. The switch will open circuit at an over temperature condition.

The diagram below shows the connection of the drive motor showing possible ancillary switches and protections. It depends on the installation whether a reversing switch and interlock with other equipment is included.

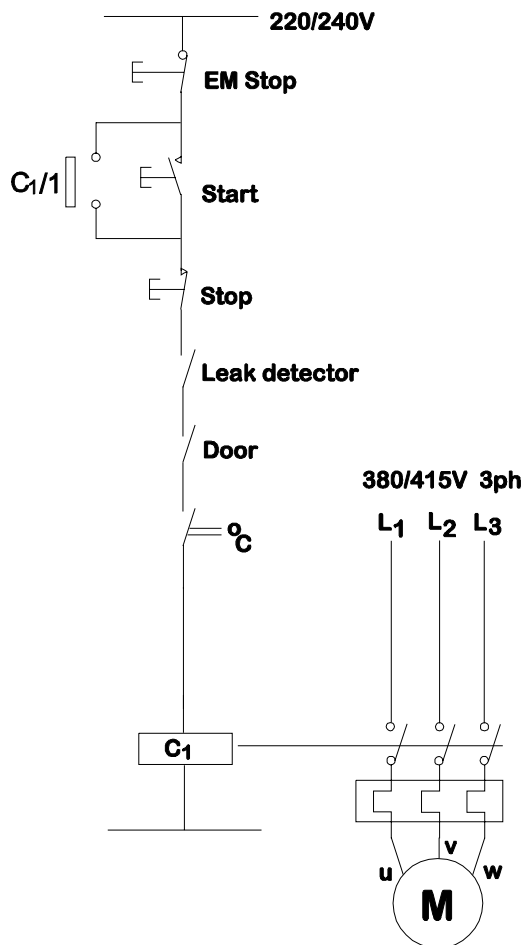

Care must be taken to ensure that the motor terminal links are in the correct position and that all connections including the earth connection are positioned correctly and securely.

Ingress protection standard will be compromised if the connection box cover is not properly replaced or if the cable gland is not correctly fitted. Exd motors must be connected with approved fitting and practice.

All pumps, excluding those intended for use in hazardous atmospheres, may be fitted with a door indicator switch. This switch is rated 240V 0.5A AC Max. Power load 50W Max. This switch is NOT intended as a primary safety device. Under normal operation the pump door is kept closed and this meets all statutory requirements as a tool lockable fixed guard.

The switch may be used directly to indicate that the door is open during maintenance, or it may be wired, following accepted fail safe practices, into a customers start up/shut down control system to

provide a back up to the Fixed Guard, whilst maintenance is being carried out. However, all normal maintenance safety practices should also be observed.



There are dangerous voltages (at mains potential) inside the motor. If access is required, isolate the pump from the mains before removing the cover.

Powered tube removal

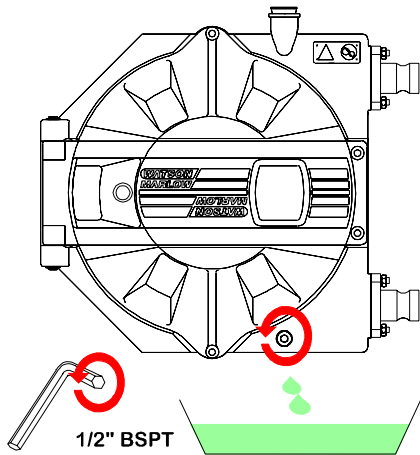

Place a container under the pumphead, then remove the lubricant drainage plug and the lubricant filler plug. Allow the lubricant to drain from the pumphead.

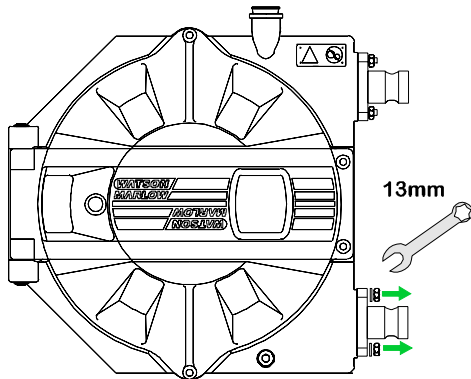

Loosen and remove the four securing nuts on the lower casing port connector using a 13mm spanner.

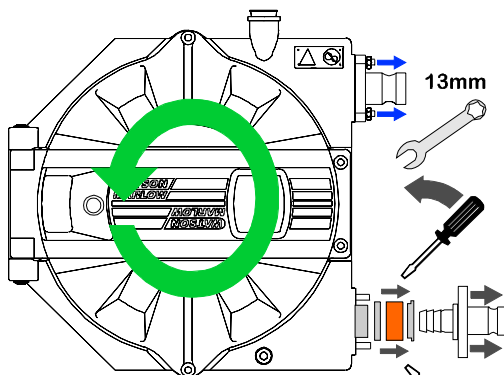

If the pump is a variable speed unit, run at a slow speed. Run the pump anticlockwise until the support ring, compression gland and the compression ring are outside of the pump.

Stop the pump and with two levers, lever the connector out of the tube, then slide off the support and compression rings and the compression gland. Remove the four securing nuts on the upper casing port connector using a 13mm spanner.

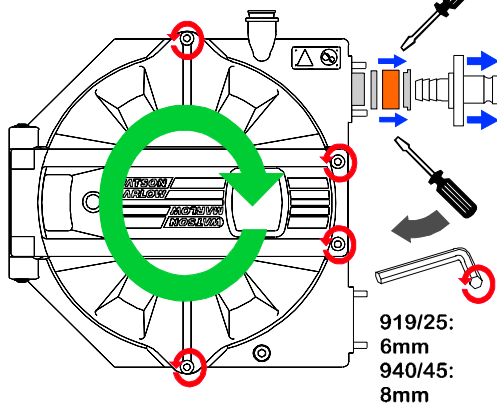

Reverse the direction of rotation of the rotor to allow the tube to be driven out of the pumphead.

Remove the four door locking screws using the Allen key supplied.



Isolate the motor from the mains supply before opening the pumphead door.

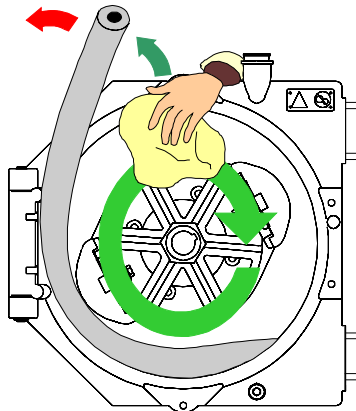

Swing the pumphead door open. Remove the tube from the pumphead.

Check that there is no debris inside the casing and that it is clean. Check that the front casing lubricant seal is not damaged, then secure the door with the four door locking screws and the Allen key supplied ensuring the seal is seated correctly.

Powered tube fitting



Isolate the motor from the mains supply before opening the pumphead door.

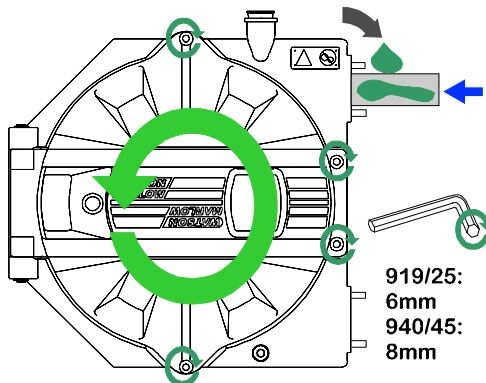

Close and lock the pumphead door with the four door locking screws and Allen key supplied.

Take a new piece of tubing and smear Silicone grease or tube lubricating oil on the outside of the tube. Connect motor to the mains supply. Start the pump and with care, feed the tube into the pumphead following the anticlockwise rotation of the rotor. Continue feeding until the other end of the tube is level with the pump face. Stop the motor.

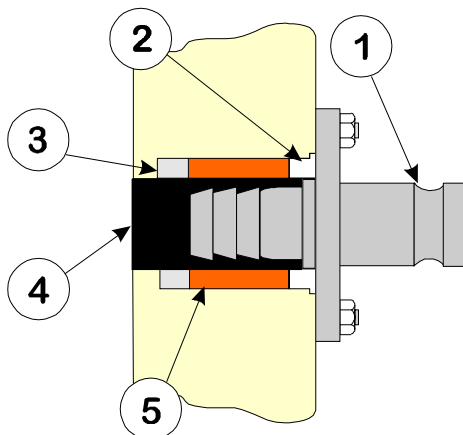

Slide the support ring (the shortest ring), compression gland and the compression ring (which has a step to allow ease of location into the tube port) onto the tube. Push the connector into the pipe.

Repeat for the other end of the tube.

- ① Connector
- ② Compression ring
- ③ Support ring
- ④ Tube
- ⑤ Compression gland

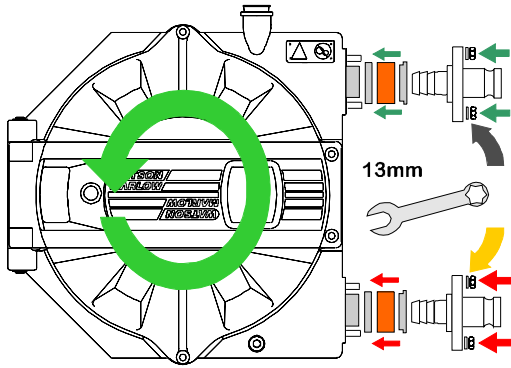

Locate the upper port connector with the securing nuts and the Allen key supplied.

Rotate the rotor anticlockwise and drive the other end of the tube out of the lower casing port. Locate the support ring, compression gland and compression ring.

Locate the lower port connector using the securing nuts and Allen key supplied.

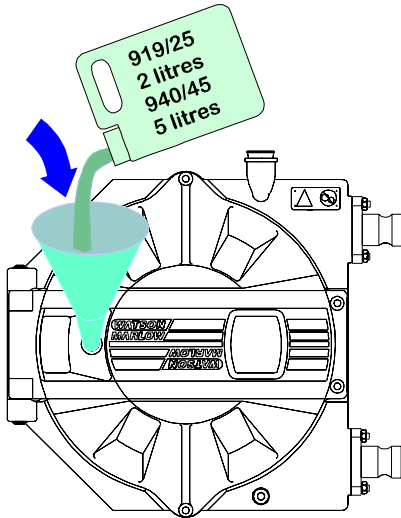

Replace the lubricant drainage plug then fill the pumphead with lubricant to the specified volume. The window in the pumphead door is a motion window and provides a visual indication of the rotation of the rotor within the pumphead. This window should not be used as lubricant level indicator.

Locate and secure the lubricant filler plug.

Manual tube removal



Isolate the motor from the mains supply before opening the pumphead door.

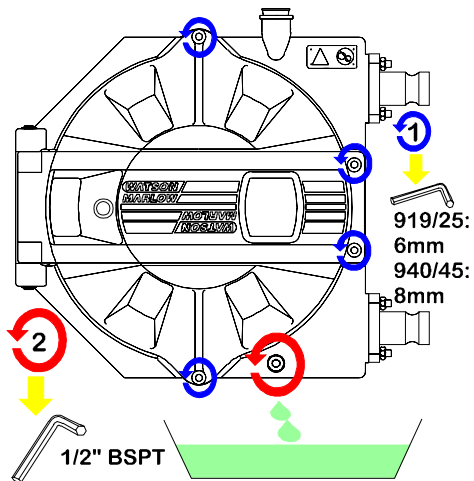

Place a container under the pumphead, then remove the lubricant drainage plug and the lubricant filler plug. Allow the lubricant to drain from the pumphead.

Remove the four door locking screws with the Allen key supplied. Swing the pumphead door open.

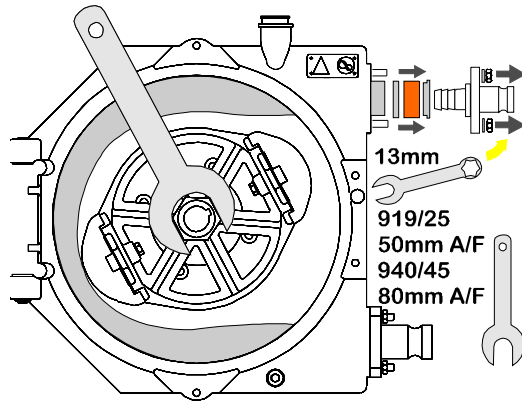

Loosen the upper casing port connector securing nuts using a 13mm spanner. Locate a spanner on the cast hexagonal nut of the rotor. Rotate the rotor clockwise until one pump head shoe has left contact with the tube completely and the tubing has been forced out of the upper casing port.

Lever the connector out of the tube. Slide off the compression ring and sealing gland.

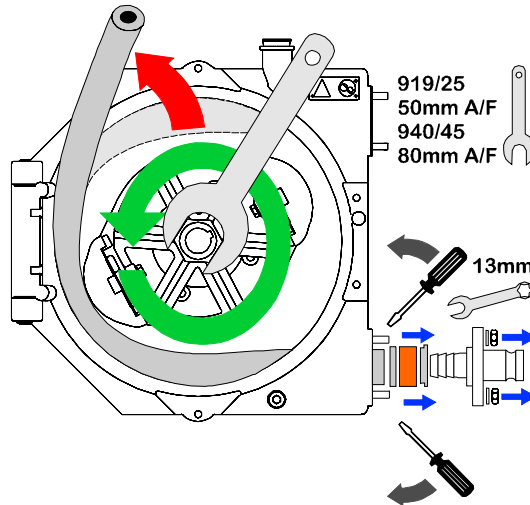

Pull the end of the tube out of the upper casing port and remove the support ring. Whilst still holding the tube, rotate the rotor anticlockwise to enable the tube to be withdrawn from the pumphead. When the second shoe is clear of the tube, remove the lower casing port connector, compression ring and sealing gland. Remove the tube completely from the pumphead along with the lower support ring.

Manual tube fitting



Isolate the motor from the mains supply before opening the pumphead door.

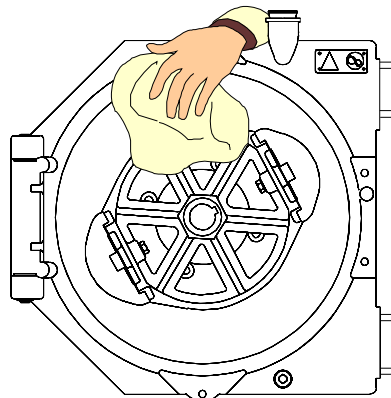

Clean the inside and faces of both casing ports, the compression and support rings and sealing gland. Clean the door sealing face ensuring that the lubricant seal is intact.

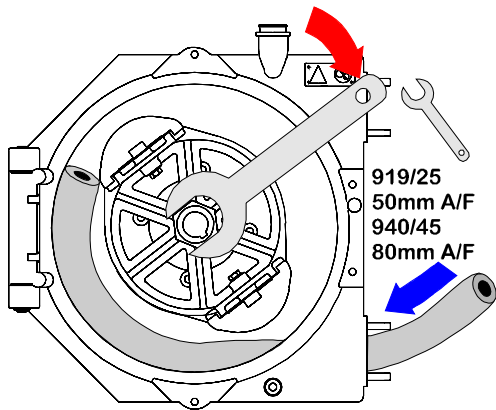

Take a new piece of tubing and smear Silicone grease or tube lubricating oil on the outside of the tube. Insert the tube into the lower casing port until it makes contact with the rotor shoe.

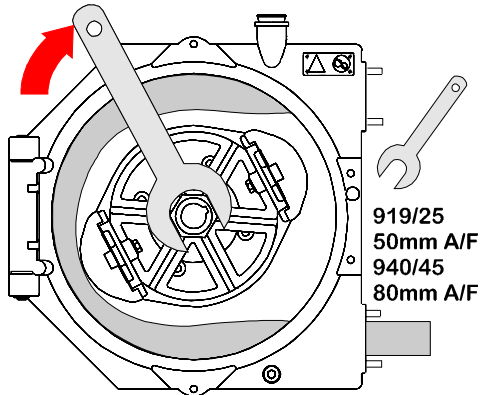

Rotate the rotor whilst inserting the tube to draw the remainder of the tube into the pumphead. Continue until approximately 100mm of tube remains protruding through the lower casing port.

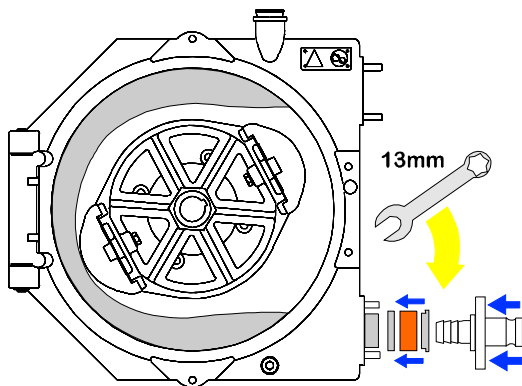

Slide a support ring (the shortest ring), a compression gland, and a compression ring onto the tube. Push the connector into the tube. (See next illustration for detail).

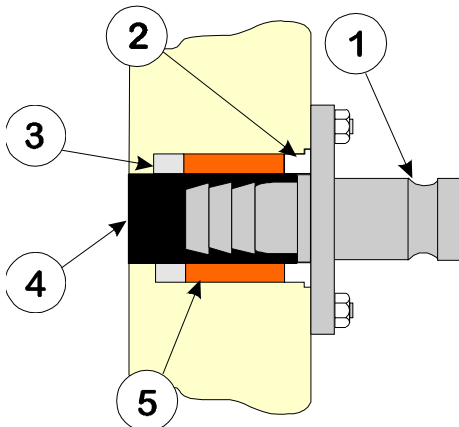

- ① Connector
- ② Compression ring
- ③ Support ring
- ④ Tube
- ⑤ Compression gland

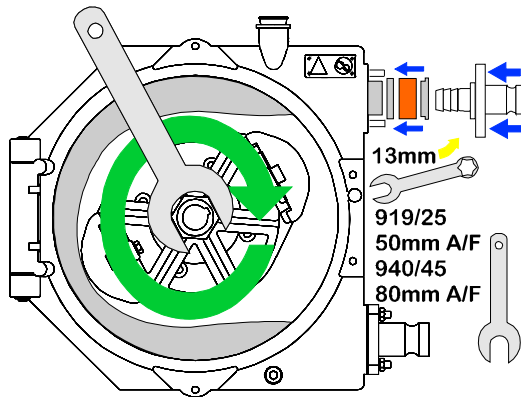

Continue to rotate the rotor until the lower tube connector is flush with the port outer face. Tighten the connector securing nuts to avoid pulling the tube back through the lower port.

Repeat connector fitting procedure for the other end of the tube in the upper casing port. Rotate the rotor to ensure that the tube is seated in the pumphead correctly.

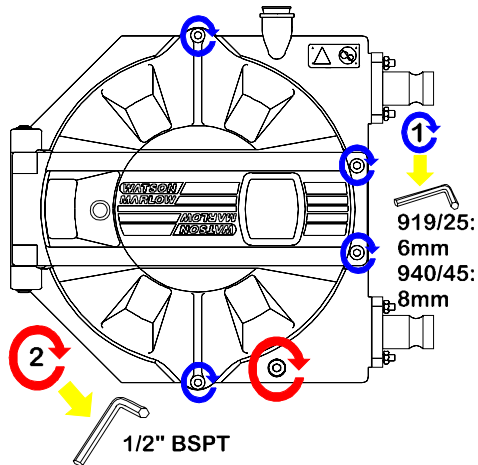

Swing the pumphead door closed and lock shut using the door locking screws and the Allen key supplied. Locate and secure the lubricant drainage plug.

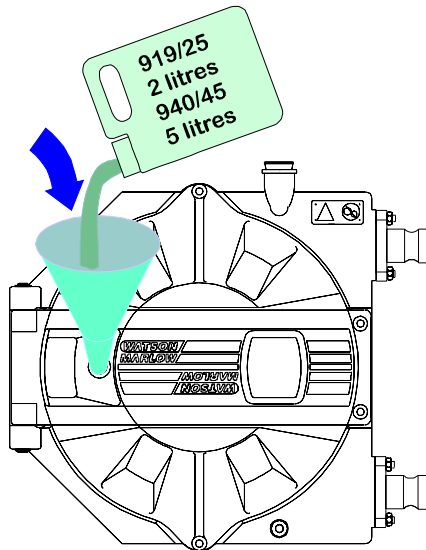

Replace the lubricant drainage plug then fill the pumphead with lubricant to the specified volume.

The window in the pumphead door is a motion window and provides a visual indication of the rotation of the rotor within the pumphead. This window should not be used as lubricant level indicator.

Locate and secure the lubricant filler plug.

Shoe adjustment

Normally when a pump is set up for an application there will be no need to re-adjust the shim setting.

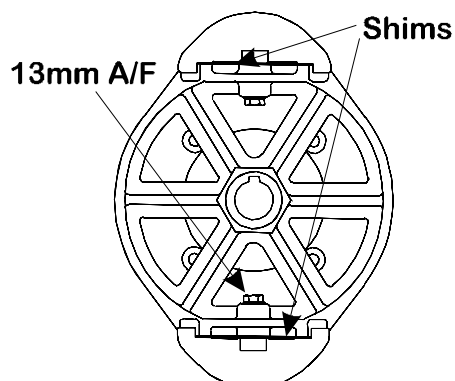

The occlusion of the tube is adjusted by varying the number of shims that are between the shoe and the rotor.

To add or remove shims loosen the hexagon screw (13mm A/F) several turns.

Check that the number of shims fitted under the sliding shoe is suitable for the operating conditions of the pump.

25mm and 19mm	10-15 bar	5-10 bar	2-5 bar	0-2 bar
0-25 rpm	5	4	3	1
25-50 rpm	4	3	2	1
50-75 rpm	4	3	2	1
75-100 rpm	3	3	1	0

40mm and 45mm	10-15 bar	5-10 bar	2-5 bar	0-2 bar
0-25 rpm	4	3	2	1
25-50 rpm	4	3	2	1
50-75 rpm	3	2	1	1
75-100 rpm	3	2	1	1

Increasing the number of shims under the sliding shoes will increase tube occlusion for higher pressure operation.

This will reduce the overall tube life when compared to using fewer shims for lower pressure operation. For temperatures above 60C - use one shim less.



Part 2: Operation

Flow rates

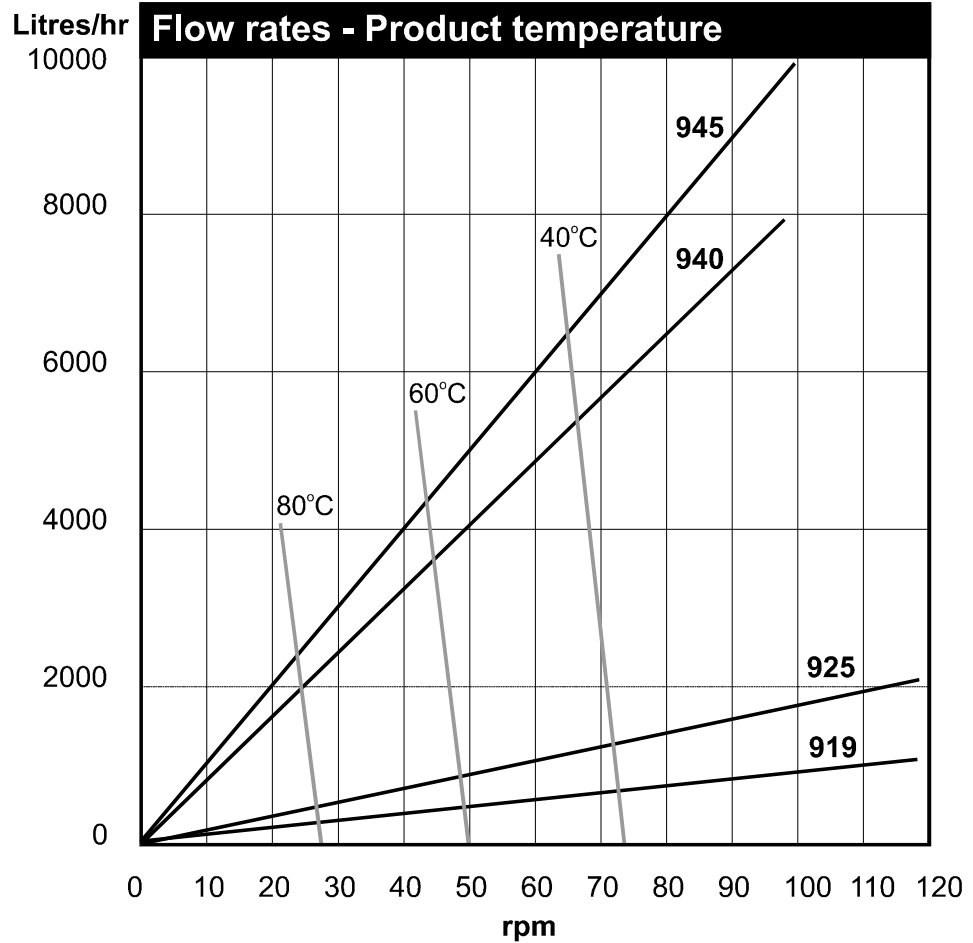

The following motor power/ tube life graphs apply to fixed speed units only. For variable speed units the motors should be de-rated by 20%.

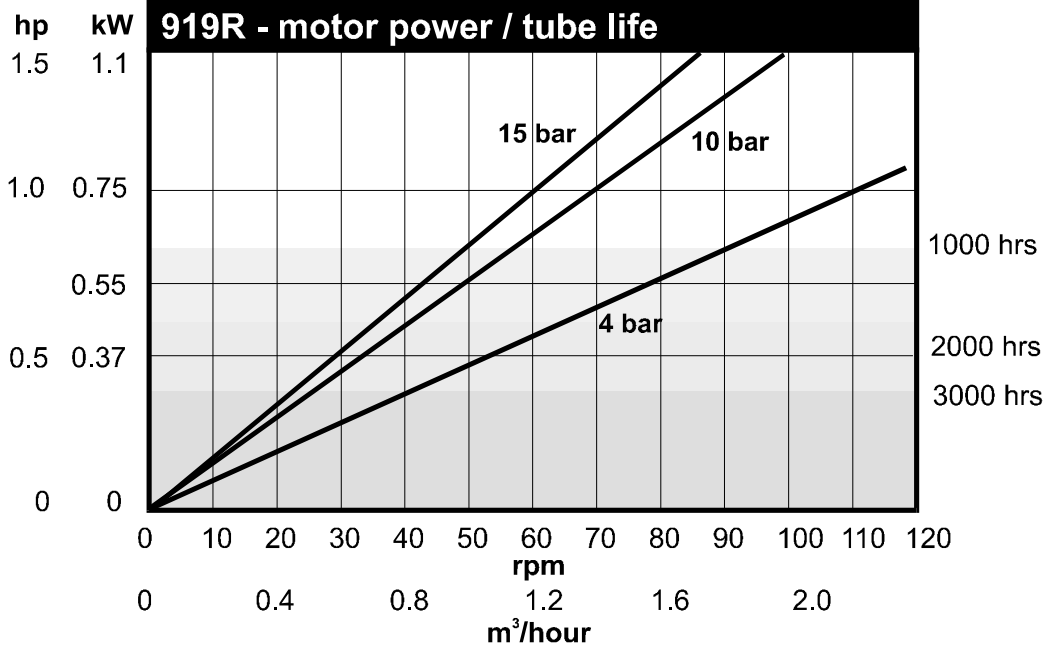

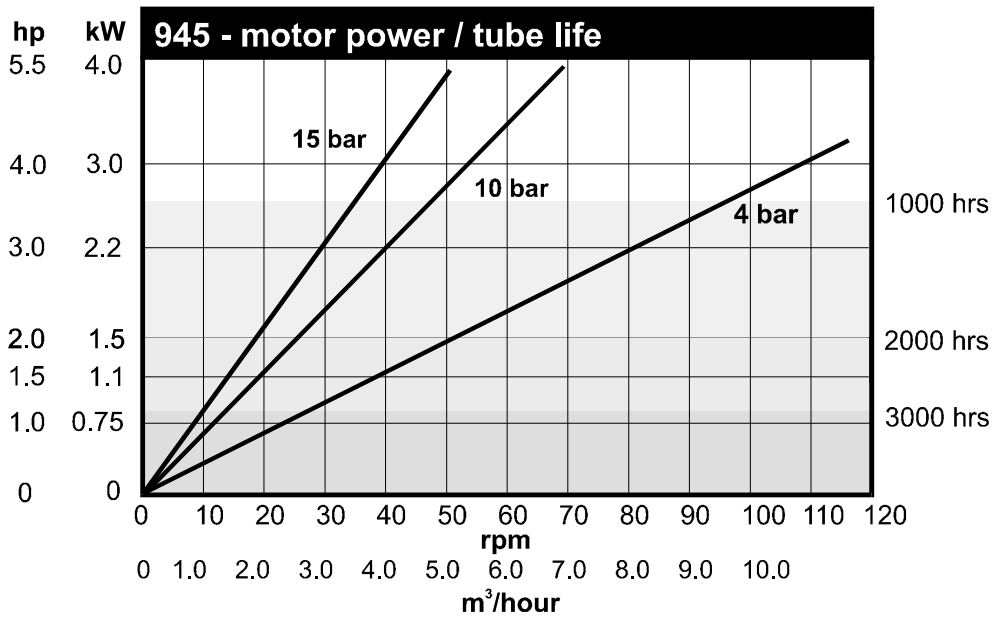
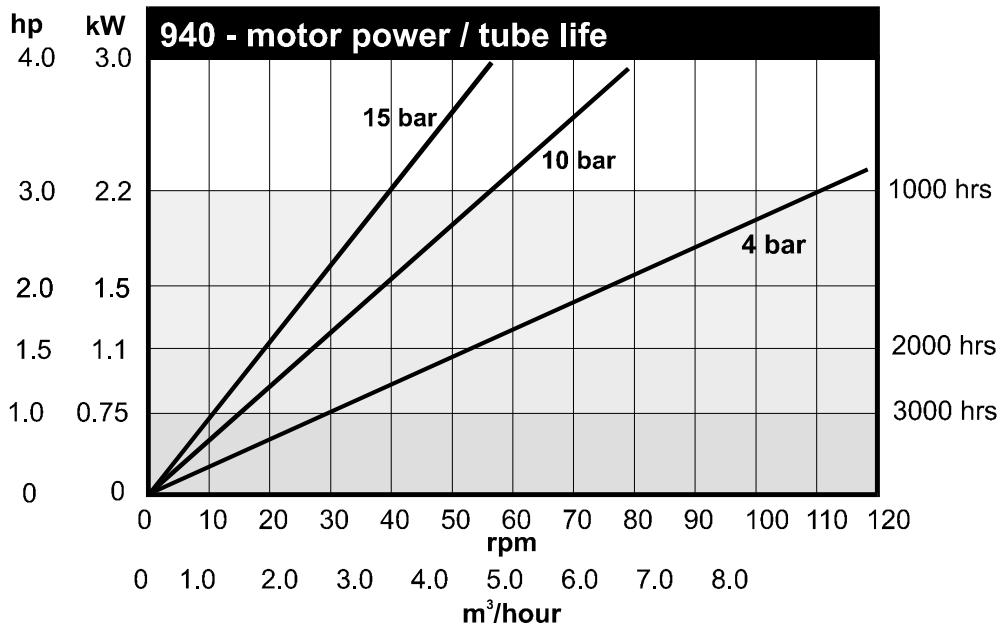
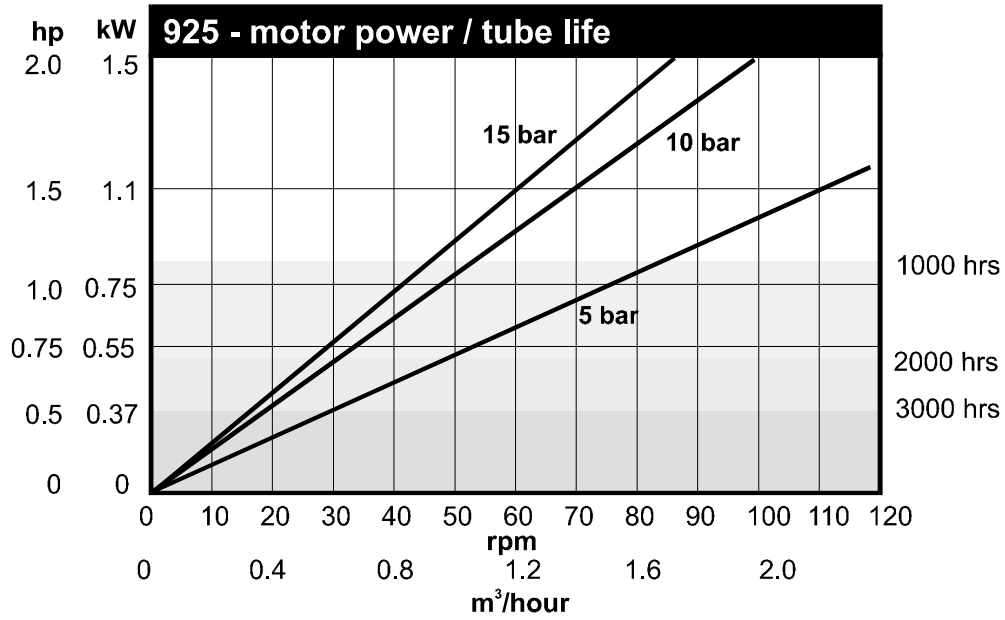

Part 3: Appendices

Spares

919/925

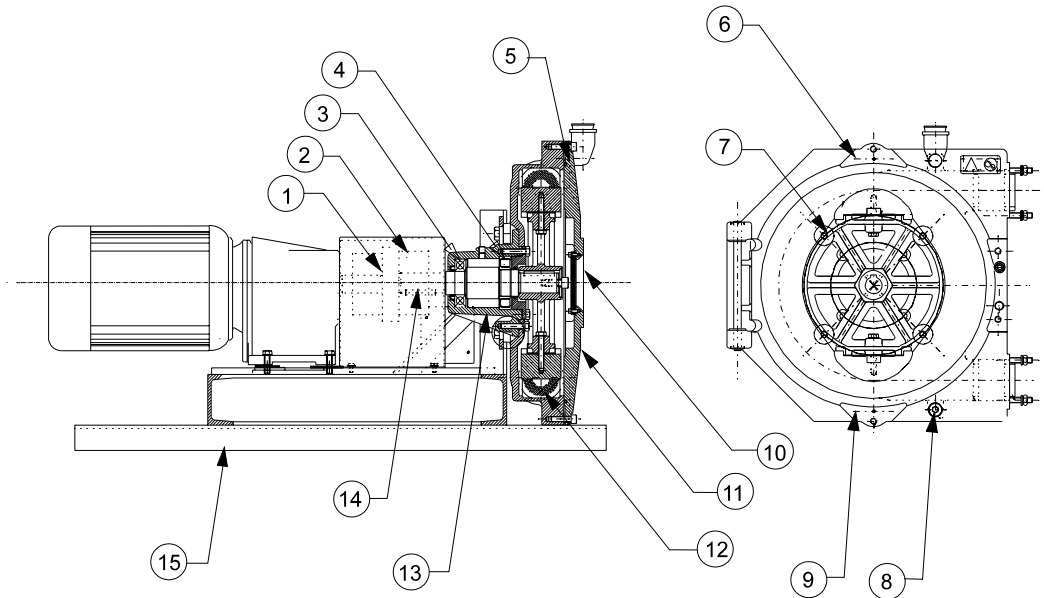

Spares	Description	Quantity	Item
SW 0156	Door indicator switch	1	
HF 1302C	Door	1	11
HF 1005S	Window	1	10
HF 1009S	Shim	8	6
HF 1003C	919 rotor	1	7
* HF 1303C	925 rotor	1	7
FN 2806	Blanking plug	1	8
HF 1004C	Shoe	2	9
HF 1305C	Frame support B/RA	1	15
* HF 1304C	Frame support FB/R	1	15
TT 0001	6mm A/F Allen key	1	
099.0002.000	Lubricant	2 litres	
OS0030	Seal	1	5
CN 0146	Coupling half	2	2
CN 0147	Coupling spider	2	1
HFA1305A	Bareshaft adaptor	1	13
HF 1310T	Bareshaft	1	14
BB 0045	Front bareshaft bearing	1	4
HF 1015T	919 8mm ring connector	1	12
HF 1012T	919 16mm ring connector	1	12
HF 1017M	919 compression gland	1	12
HF 1315T	925 8mm ring connector	1	12
HF 1312T	925 16mm ring connector	1	12
HF 1317M	925 compression gland	1	12
BB 0039	Rear bareshaft bearing	1	3

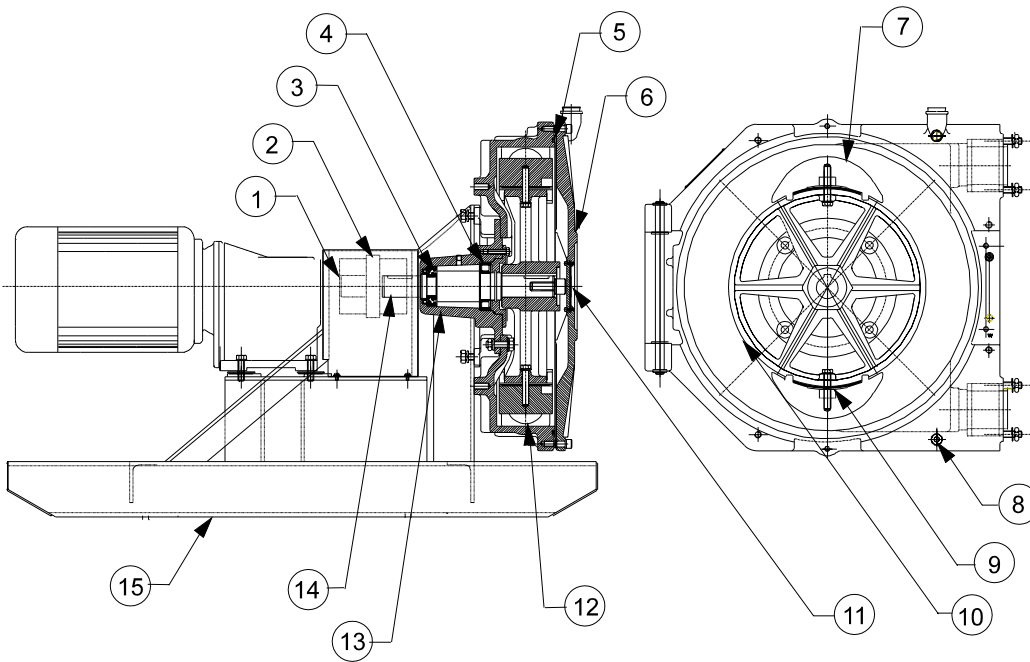

Spares	Description	Quantity	Item
SW 0156	Door indicator switch	1	
HF 1102S	Door	1	6
HF 1005S	Window	1	11
HF 1109S	Shim	8	9
HF 1103C	Rotor	1	10
FN 2806	Blanking plug	1	8
HF 1104T	Shoe	2	7
HF 1123C	Frame support B/RA	1	15
* HF 1105C	Frame support FB/R	1	15
TT 0007	8mm A/F Allen key	1	
OS 0030	Seal	1	5
099.0005.000	Lubricant	5 litres	
CN 0144	Coupling half	2	1
HF 1120T	Bareshaft		14
CN 0145	Coupling spider	1	2
HFA1105A	Bareshaft adaptor	1	13
BB0046	Front bareshaft bearing	1	4
BB0042	Rear bareshaft bearing	1	3
HF 1115T	940 8mm ring connector	1	12
HF 1116T	940 16mm ring connector	1	12
HF 1117M	940 compression gland	1	12
HF 1161T	945 8mm ring connector	1	12
HF 1162T	945 16mm ring connector	1	12
HF 1163M	945 compression gland	1	12

Materials of construction

Description	Material	Comment
Pumphead Body Pumphead Door	Cast iron	A high quality and strength cast iron, with an epoxy polyester powder coat finish
Pumphead Rotor	Grey iron	Epoxy polyester powder coat
Rotor Shoes	Aluminium	
Frame	Mild steel	Epoxy polyester powder coat
Flanges	Mild steel, stainless steel, aluminium or polypropylene	See separate section on flanges
Studs for connectors	Stainless steel	
Door fixings	High tensile steel	
Motor fixings	High tensile steel	
Frame fixings	Stainless steel	
Tube sealing glands	Neoprene	See section on tube connection
Tube lubricant	Glycerine	Green in colour

Specification

Control range	See pump specification label
Voltage/frequency	See motor specification label
Power consumption	See motor specification label
Operating temperature range	5C to 40C
Storage temperature range	-40C to 70C
Noise	<70dBA at 1m
Standards	IEC 335-1, EN60529 (IP55) Machinery Directive: 89/392/EEC EN60204-1 Low Voltage Directive: 73/23/EEC EN61010-1 EMC Directive: 89/336/EEC EN50081-1/50082-1

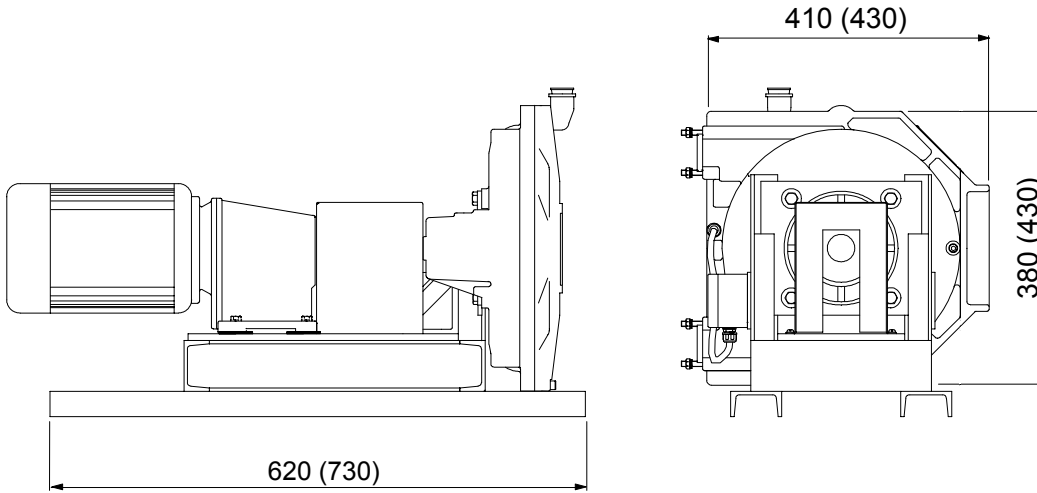

NORMAL DIMENSIONS REPRESENT 919
DIMENSIONS IN BRACKETS REPRESENT 925

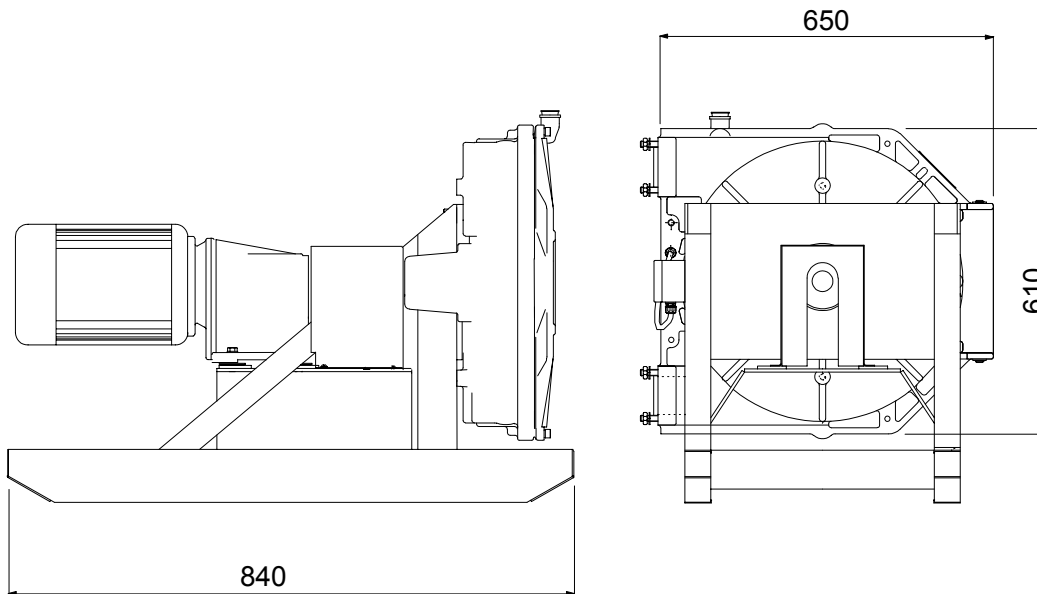

Decontamination certificate

Watson-Marlow Limited Health and Safety Declaration	
<p>1.0 This procedure is a legal requirement in the UK and must be used when returning pumps and equipment for service at Watson-Marlow (or its distributor).</p> <p>2.0 Pumps returned for service must be cleaned. You are responsible for their decontamination.</p>	<p>3.0 Either fax this form or send by first class post to Watson-Marlow (or its distributor) to ensure that we have the information before receipt of the equipment.</p> <p>A further copy must be attached to the outside of the shipping case.</p>
Failure to complete the form or comply with the procedure will cause delays in servicing the equipment.	
<p>4.0 Company Address Telephone Post Code..... Fax number.....</p>	
<p>5.0 Please complete all the following sections</p> <p>5.1 Pump Type.....</p> <p>5.2 Serial number.....</p> <p>5.3 Details of substances pumped</p> <p>5.3.1 Chemical names: (a) (b) (c) (d)</p> <p>5.3.2 Precautions to be taken in handling these substances: (a) (b) (c) (d)</p> <p>5.3.3 Action to be taken in the event of human contact: (a) (b) (c) (d)</p> <p>5.3.4 Cleaning fluid to be used if residue of chemicals is found during servicing: (a) (b) (c) (d)</p>	<p>5.4 If substances are not hazardous nor toxic, please complete section 5.4.1. If substances are hazardous or toxic, please complete section 5.4.2.</p> <p>5.4.1 I hereby confirm that the equipment specified has not pumped nor come into contact with any toxic or hazardous substances.</p> <p>Signed..... Name..... Position..... Date.....</p> <p>5.4.2 I hereby confirm that the only toxic or hazardous substance(s) that the equipment specified has pumped or come into contact with are those named, and that the information given is correct and the carrier has been informed if the consignment is of a hazardous nature.</p> <p>Signed..... Name..... Position..... Date.....</p> <p>5.5 Carrier to be used Delivery date </p> <p>5.6 Fault description or any other information </p>
<p>IMPORTANT Before returning any product for service, this form must be completed and sent to Watson-Marlow, or its subsidiary, or its official distributor undertaking the service</p>	

Watson-Marlow Limited, Falmouth, Cornwall TR11 4RU, England. Tel 01326 370370, Fax 01326 376009