

# 401U



## Declarations

**Declaration of conformity**  When this pump unit is used as a stand alone pump it complies with: Machinery Directive 2006/42/EC, EMC Directive 2004/108/EC.

**Declaration of Incorporation** When this pump unit is to be installed into a machine or is to be assembled with other machines for installations, it must not be put into service until the relevant machinery has been declared in conformity with the Machinery Directive 2006/42/EC.

Responsible person: Christopher Gadsden, Managing Director, Watson-Marlow Limited, Falmouth, Cornwall TR11 4RU, England. Telephone +44 (0) 1326 370370. Fax +44 (0) 1326 376009.



## Two year warranty

Watson-Marlow Limited warrants, subject to the conditions below, through either Watson-Marlow Limited, its subsidiaries, or its authorised distributors, to repair or replace free of charge, including labour, any part of this product which fails within two years of delivery of the product to the end user. Such failure must have occurred because of defect in material or workmanship and not as a result of operation of the product other than in accordance with the instructions given in this manual.

Conditions of and specific exceptions to the above warranty are

- Consumable items such as tubing, rollers and motor brushes are excluded.
- Products must be returned by pre-arrangement carriage paid to Watson-Marlow Limited, its subsidiaries, or its authorised distributor.
- All repairs or modifications must have been made by Watson-Marlow Limited, its subsidiaries, or its authorised distributors or with the express permission of Watson-Marlow Limited, its subsidiaries, or its authorised distributors.
- Products which have been abused, misused, or subjected to malicious or accidental damage or electrical surge are excluded.

Warranties purporting to be on behalf of Watson-Marlow Limited made by any person, including representatives of Watson-Marlow Limited, its subsidiaries, or its distributors, which do not accord with the terms of this warranty shall not be binding upon Watson-Marlow Limited unless expressly approved in writing by a director or manager of Watson-Marlow Limited.

## Information for returning pumps

Equipment which has been contaminated with, or exposed to, body fluids, toxic chemicals or any other substance hazardous to health must be decontaminated before it is returned to Watson-Marlow Limited or its distributor.

A certificate included at the rear of these operating instructions, or signed statement, must be attached to the outside of the shipping carton.

This certificate is required even if the pump is unused. If the pump has been used, the fluids that have been in contact with the pump and the cleaning procedure must be specified along with a statement that the equipment has been decontaminated.

## Safety

In the interests of safety, this pump and the tubing selected should only be used by competent, suitably trained personnel after they have read and understood this manual, and considered any hazard involved.

Any person who is involved in the installation or maintenance of this equipment should be fully competent to carry out the work. In the UK this person should also be familiar with the Health and Safety at Work Act 1974.



***There are no user serviceable parts inside this pump. The unit should be turned to Watson-Marlow for service.***

## Installation

- The 401U/D is suitable for single phase mains electricity supplies only via the 230VAC-15VAC mains transformer or a 100-240VAC-18VDC mains adaptor. The **CW/STOP/CCW** front panel potentiometer should be set in the **STOP** position before the power supply is connected by inserting the mains transformer jack plug into the back panel socket.
- Use only the approved 15V Mascot type 810 AC/AC adaptor or the 18VDC CMP SA07H18 AC/DC adaptor supplied with the pump.
- To ensure correct lubrication of the gearbox, the pump should be run only while its feet are standing on a horizontal surface. The pump should be positioned to allow a free flow of air around it.

## Recommended operating procedures

**DO** keep delivery and suction lines as short as possible using a minimum number of swept bends.

**DO** use suction and delivery pipelines with a bore equal to or larger than the bore of the tube fitted in the pumphead. When pumping **viscous** fluids, the losses caused by increased friction can be overcome by using pipe runs with a cross sectional area several times greater than the pumping element.

**DO** run at a slow speed when pumping viscous fluids.

**DO** fit an extra length of pump tube in the system to enable tube transfer. This will extend tube life and minimise the downtime of the pumping circuit.

**DO** keep the track and rollers clean.

The self-priming nature of peristaltic pumps means valves are not required. Any valves fitted must cause no restriction to flow in the pumping circuit.

**When using Marprene tubing** After the first 30 minutes of running, re-tension the tube in the pumphead by releasing the track latch and pulling the tubing on the delivery side a little. This is to counteract the normal stretching that occurs with Marprene which can go unnoticed and result in poor tube life.

**Tube selection** The chemical compatibility list published in the Watson-Marlow catalogue is only a guide. If in doubt about the compatibility of a tube material and the duty fluid, request a tube sample card for immersion trials.

## Troubleshooting

If the pump fails to operate, make the following checks to determine whether or not servicing is required.

- Check the mains supply is available at the pump (green LED).
- Check the fuse in the mains socket (where fitted).
- Check that the pump is not stalled by incorrect fitting of tubing.

## Manual operation

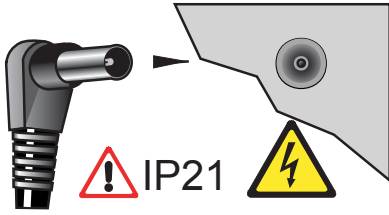

- Insert the mains transformer jack plug into the round socket on the pump back panel.



18VDC CMP SA07H18



EU US UK AU

- Pumps delivered with multi-plug mains adaptor: see pictures above for how to change plugs.
- Switch power on at the mains socket. Power at the pump will be signalled by the illumination of a green LED on the pump front panel.
- The manual speed control potentiometer has three positions.

Centre position (III) means that the pump rotor will be stopped

**cw** position (III) means the rotor will rotate clockwise at its set speed

**ccw** position (III) means the rotor will rotate counter-clockwise at its set speed.

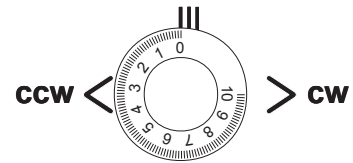
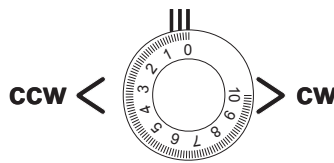
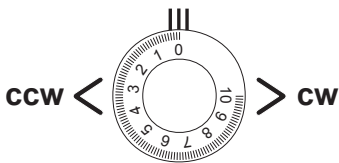

- The speed setting dial is calibrated in proportion of maximum speed from 0-10 which represents a 10:1 speed reduction ratio from the maximum speed of the pump. Turn the control knob clockwise to increase the speed and counter-clockwise to decrease the speed.
- When changing the direction of flow, turn the **ccw<off>cw** switch to its central **off** position until the pumphead rotor stops; then turn it to the required direction of rotation which will re-start the pump.
- If returning from auto control to manual control, disconnect the process signal from the pump.



***In the event of a power failure, the pump will automatically re-start when the power is returned. This will occur under manual or remote control.***

## Remote control

The 401U pump can be controlled remotely via 0-10V or 4-20 mA analogue signals. 400AC1, 400AC2, 400AC3 and 400AC4 remote control cables with a 15-pin D-sub connector are available from your local Watson-Marlow dealer. Wiring diagrams for each control cable are shown at the bottom of this section.

When using the **400AC1** (0-10V) or **400AC2** (4-20mA) remote control cables for analogue speed control and switching cw/stop/ccw:

- Set the front panel control potentiometer to the centre position (stop).
- The manual speed control potentiometer sets the range of the remote speed signal, and it can be adjusted during remote control use. If the manual speed is set to 5 the remote control works for speeds 0-50%. Set the manual control potentiometer to 10 for full analogue speed range control.
- Start or stop the pump in either cw or ccw direction remotely as shown in the relevant wiring diagrams. If the remote switch is set to stop, cw or ccw direction switching can be achieved using the front control potentiometer.

When using the **400AC3** cw/stop/ccw remote cable

- Set the pump speed using the manual speed control potentiometer.
- Start or stop the pump in either cw or ccw direction remotely as shown in the relevant wiring diagram. If the remote switch is set to stop, cw or ccw direction switching can be achieved using the front control potentiometer.

When using the **400AC4** start/stop 3m remote cable with footswitch fitted:

- Set the pump speed and direction of rotation via the manual speed control potentiometer.
- Start or stop the pump remotely as shown in the relevant wiring diagram.

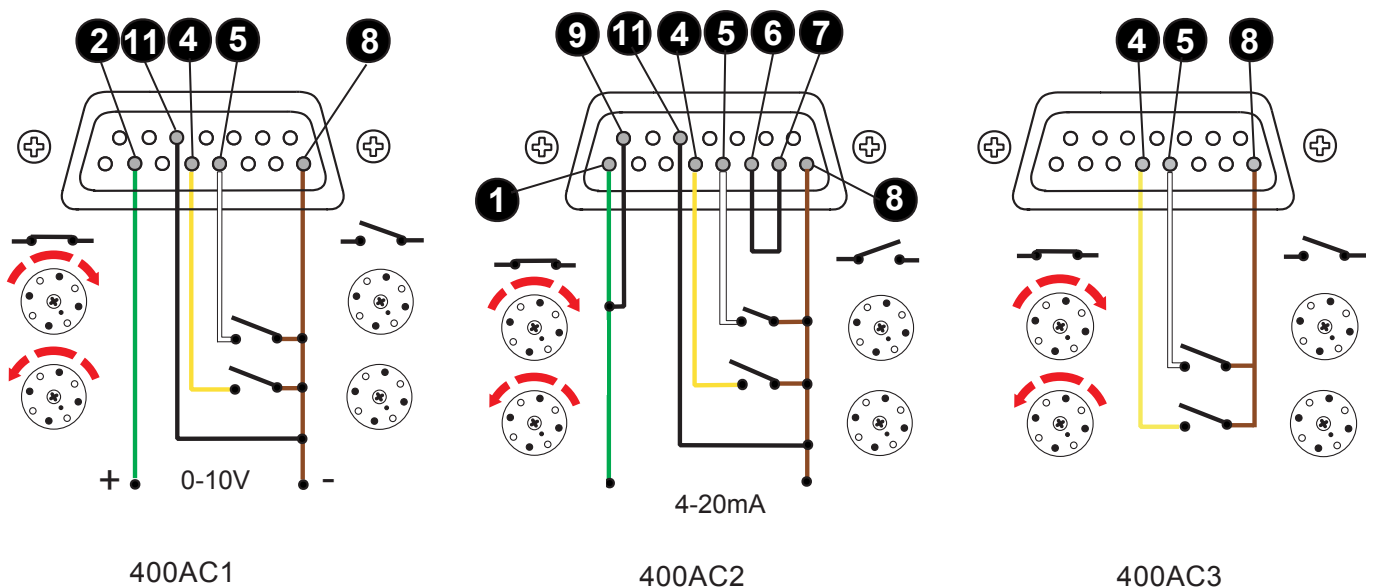

## Care and maintenance

The only scheduled maintenance of the pump unit is to inspect the motor brushes and to replace them when necessary, understanding that motor brushes are not covered by the two-year warranty. It is recommended that all maintenance to this pump is carried out by a Watson-Marlow servicing agent.

The life of the brushes depends on the duty of the pump but is expected to be at least 2500 hours.

If the pump requires cleaning use a mild solution of detergent in water after removing the pumphead. Do not use strong solvents.

## Pump spares

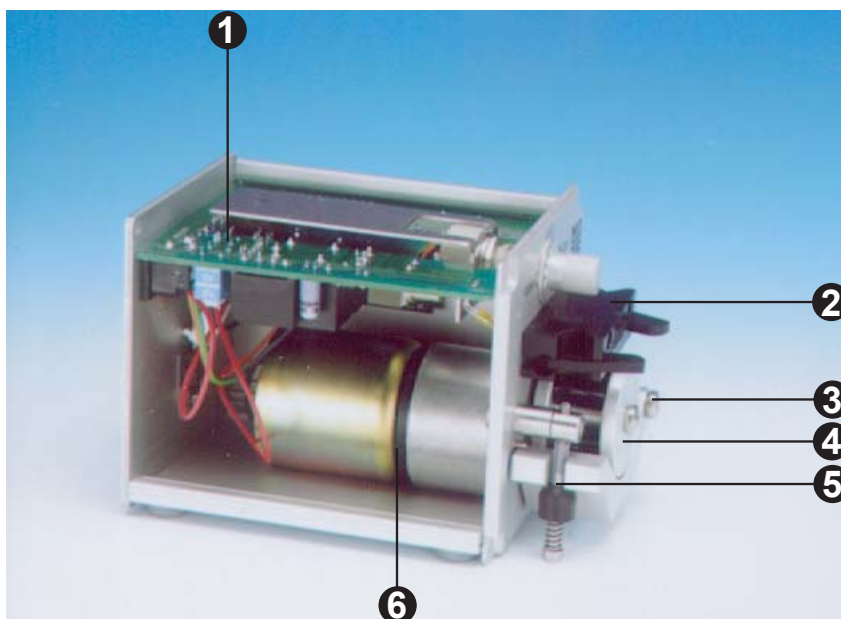

Number	Part number	Description
1	100 724-MINI, 400-S	Control board
2	010041	Tube clamps D1
	000107	Tube clamps DM2
	000078	Tube clamps DM3
3	MRX M4x6 A4	Rotor screws
4	010014	Rotor D1
	010015	Rotor DM2
	010016	Rotor DM3
5	010038	Occlusion arm
6	970113 16843 75:1	Motor gearbox kit
	MFX M3x8 A4	Gearbox screws
	D6 B 35x10 NN A542 SPTAND A4	Case screws

## Specification

Maximum rotor speeds for 400D	15rpm, 40rpm, 200rpm
Maximum rotor speeds for 400DM	15rpm, 40rpm, 100rpm
Voltage/frequency	15VAC / 18VDC
Control range	10:1
Operating temperature range	5 to 40C
Storage temperature range	-40C to 70C
Weight	1.0kg
Noise	<70 dBA @ 1m
Standards	EN60529 (IP21) Machinery Directive 2006/42/EC EMC Directive 2004/108/EC



## 400D, 400DM2 and 400DM3 pumpheads

### Tube life and performance against pressure

The pressure and the suction height can be increased by compressing the spring in the sprung track pin. A smaller gap between the rollers and track will give better performance against pressure but will reduce tube life.

Other application factors that will influence tube life in peristaltic pumps are pump speed and number of rollers (roller impacts/minute), temperature, chemical compatibility of the duty fluid and viscosity of the duty fluid. Several tubing materials are available offering different levels of life expectancy. The tubing's dimensional tolerances from the manufacturing process will also influence the life of a tube.

This means that it is impossible to predict tube life in any particular application.

In perfect conditions of no suction or discharge pressure, in a clean environment at normal room temperature, and pumping water, nominal tube life may be:

Marprene and Bioprene	less than 6,000 hours
Silicone	less than 250 hours
Others	less than 100 hours

The factors highlighted above will tend to reduce tube life. Users are advised to determine likely tube life in their application and make routine tube changes at suitable intervals.

### Key Safety Information

#### *Before changing the tubing in the pumphead*

- Ensure that there is no pressure, liquid or gas in the pipeline.
- Disconnect the pump from the mains to prevent the pump from starting unexpectedly.
- Always replace any protective guard after tube changeover.
- If a tube failure has occurred, ensure that any product in the pumphead has been allowed to drain to a safe area.
- Ensure that protective clothing and eye protection are worn if aggressive products are being pumped.

### 400D pumphead setup (used on 401U/D pump)

The 400D pumphead is designed to accept 1.6mm wall standard laboratory tubing from 0.5mm bore up to 3.2mm bore. Care should be taken to establish the normal tube life experienced within a set of operating parameters. Subsequent tubing replacement should be scheduled within the normal expected life of a tube. This will avoid unnecessary tube failure and unplanned pump maintenance.

## Tube loading

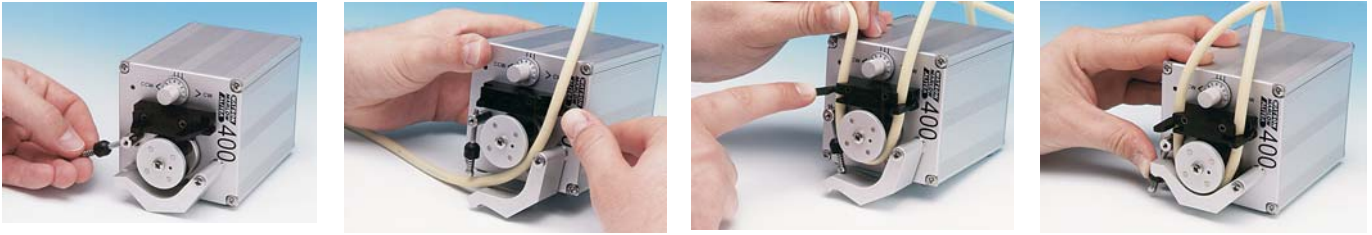

- Release the track by disengaging the sprung track pin.
- Before tube loading, make sure that enough suction and delivery tubing is available to connect into the remaining pipeline or to reach the suction reservoir and delivery point.
- Locate the tubing into the suction side tube clamp. Feed the tubing in around the rotor, maintaining reasonable tube tension so that the tube sits around the rotor, and locate into the delivery side tube clamp. Make sure that there are no twists or kinks in the tubing after loading as this will reduce tube life.
- Ensure the tube is lined up centrally in the track and correctly secured at each clamp.
- Reposition the track over the rotor and fix by slotting the track pin back into the track slot.

## Tube re-tensioning

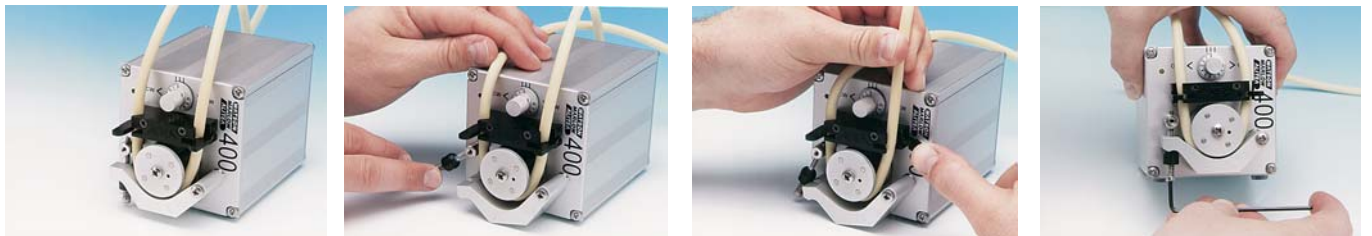

- **When using Marprene tubing** After the first 30 minutes of running, re-tension the tube in the pumphead by releasing the sprung track pin and pulling the tubing on the delivery side a little. This is to counteract the normal stretching that occurs with Marprene which can go unnoticed and result in poor tube life.

## Tube removal

- Release the track by disengaging the sprung track pin and withdraw the tubing from the sprung clamps.



## 400DM2 and 400DM3 pumpheads setup (used on 401U/D pump)

The 400DM2 and 400DM3 pumpheads are designed to accept three-bridge manifold tubing only. Each piece of three-bridge manifold tubing has two pumping sections. When flow performance falls with one section this is a sign of tube wear and should be used as an indicator to switch over to using the second section. When the switch to the second section is made, check the first section of tubing is not adversely affected by normal line pressure. If this is the case then the complete section of tubing will need to be replaced.

### Tube loading

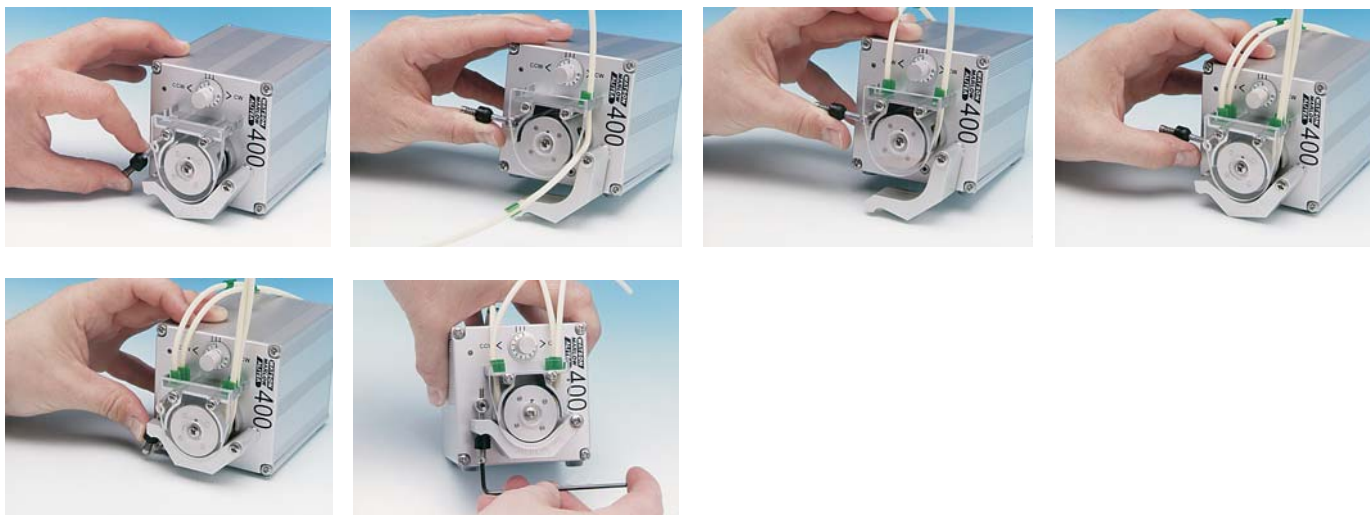

- Release the track by disengaging the sprung track pin.
- Locate the first tube bridge into the appropriate tube bridge holder slot. Feed the tubing in around the rotor. Locate the centre tube bridge into the bridge holder slot immediately opposite the first tube bridge. Repeat for the remaining one (400DM2) or two (400DM3) channels. Make sure that there are no twists or kinks in the tubing after loading as this will adversely affect tube life.

### Tube removal

- Release the track by disengaging the sprung track pin.
- Remove both tubing bridges from their location slots and remove the tubing from the pumphead.

### Pumphead spares

Description	400D1	400DM2	400DM3
Track	940418	940418	940920
Track latch (occlusion) arm	010038	010038	010038
Rotor	010014	010015	010016
Tube clamps	010041	000107	000078
Rotor screw	MRX M4X6 A4	MRX M4X6 A4	MRX M4X6 A4

## Flow rates

The tables below list the approximate water-flow rate per revolution for the 400D pumpheads. The flow rate will depend on the duty fluid (viscosity, density etc.), pressure, temperature, speed, tubing and the installation. For accurate flow rates and repeatability calibrate the pump for your application.

### 400D1

Tubing I.D. (mm) Flowrate (ml/rev)	0.5 0.012	0.8 0.056	1.6 0.087	3.2 0.425
1.2 - 12rpm	0.02-0.2	0.04-0.4	0.14-1.4	0.49-4.9
4 - 40rpm	0.07-0.7	0.14-1.4	0.48-4.8	1.6-16
20 - 200rpm	0.34-3.4	0.68-6.8	0.24-24	8.2-82

### 400DM2 & 400DM3

Colour Bore	Orange/Black 0.13mm 0.005"	Orange/Red 0.19mm 0.007"	Orange/Blue 0.25mm 0.010"	Orange/Green 0.38mm 0.015"	Orange/Yellow 0.50mm 0.020"
1-12rpm	0.002- 0.02	0.003-0.03	0.004-0.04	0.01-0.1	0.02-0.2
4-40 rpm	0.008- 0.08	0.011-0.11	0.015-1.5	0.04-0.4	0.05-0.5
10-100 rpm	0.019- 0.19	0.028-0.28	0.037-0.37	0.10-1.0	0.13-1.3
Colour Bore	Orange/White 0.63mm 0.025"	Black/Black 0.76mm 0.030"	Orange/Orange 0.88mm 0.035"	White/White 1.02mm 0.040"	Red/Red 1.14mm 0.045"
1-12rpm	0.03-0.3	0.04-0.4	0.05-0.5	0.07-0.7	0.09-0.9
4-40 rpm	0.10-1.0	0.15-1.5	0.18-1.8	0.25-2.5	0.29-2.9
10-100 rpm	0.25-2.5	0.37-3.7	0.46-4.6	0.62-6.2	0.74-7.4
Colour Bore	Grey/Grey 1.29mm 0.050"	Yellow/Yellow 1.42mm 0.055"	Yellow/Blue 1.52mm 0.060"	Blue/Blue 1.65mm 0.065"	Green/Green 1.85mm 0.07
1-12rpm	0.10-1.0	0.14-1.4	0.14-1.4	0.17-1.7	0.21-2.1
4-40 rpm	0.34-3.4	0.46-4.6	0.47-4.7	0.56-5.6	0.70-7.0
10-100 rpm	0.85-8.5	1.1-11	1.2-12	1.4-14	1.7-17
Colour Bore	Purple/Purple 2.05mm 0.080"	Purple/Black 2.38mm 0.090"	Purple/Orange 2.54mm 0.100"	Purple/White 2.79mm 0.110"	
1-12rpm	0.25-2.5	0.29-2.9	0.39-3.9	0.44-4.4	
4-40 rpm	0.84-8.4	0.98-9.8	1.3-13	1.5-15	
10-100 rpm	2.1-21	2.5-25	3.2-32	3.6-36	

## Outline dimensions

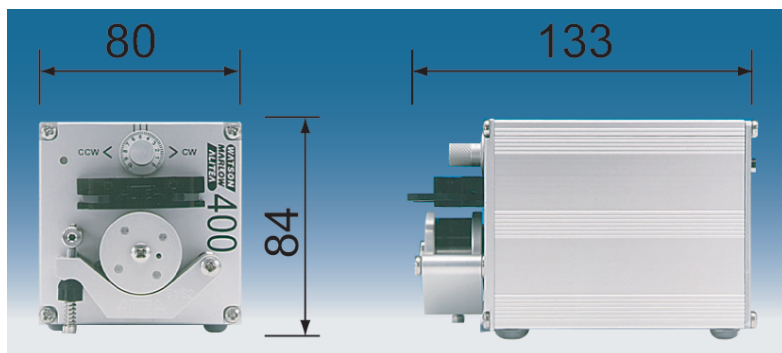

401U/D1

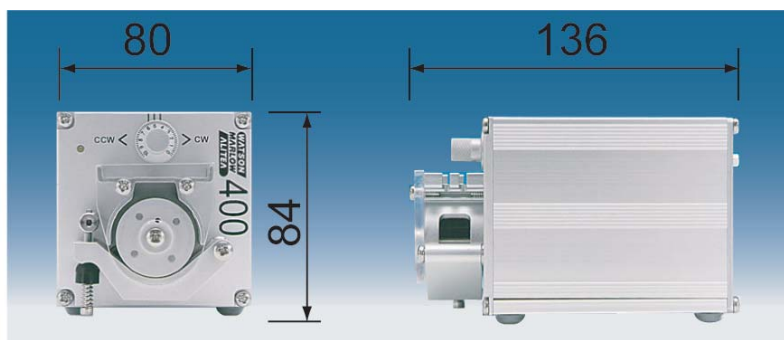

401U/DM2

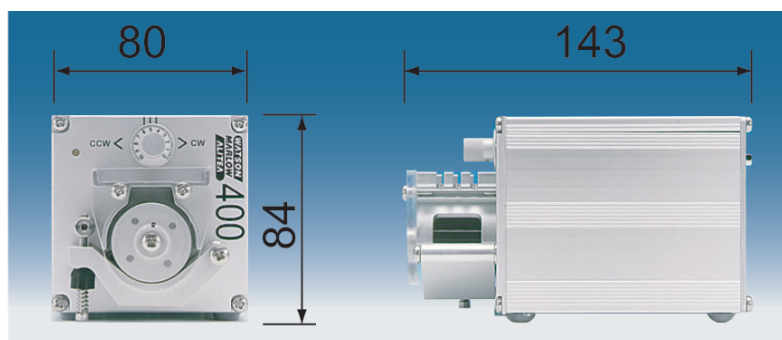

401U/DM3

---

**Watson-Marlow, Bioprene and Marprene** are trademarks of **Watson-Marlow Limited**.

**Tygon** is a trademark of the **Saint Gobain Performance Plastics** Company.

**STA-PURE** is a trademark of **W.L.Gore & Associates**.

Warning, These products are not designed for use in, and should not be used for patient connected applications.

The information contained in this document is believed to be correct but Watson-Marlow Limited accepts no liability for any errors it contains, and reserves the right to alter specifications without notice.

---

## Product Use and Decontamination Certificate

In compliance with the **UK Health & Safety at Work Act** and the **Control of Substances Hazardous to Health Regulations** you, the user are required to declare the substances which have been in contact with the product(s) you are returning to Watson-Marlow or any of its subsidiaries or distributors. Failure to do so will cause delays in servicing the product. Therefore, **please complete this form** to ensure that we have the information **before** receipt of the product(s) being returned. **A FURTHER COPY MUST BE ATTACHED TO THE OUTSIDE OF THE PACKAGING CONTAINING THE PRODUCT(S).** **You, the user, are responsible for cleaning and decontaminating the product(s) before returning them.**

Please complete a separate Decontamination Certificate for each pump returned.

**RGANo:** .....

1. Company .....

Address .....

Postcode .....

Telephone ..... Fax number .....

2. Product .....

2.1 Serial number .....

2.2 Has the product been used?

YES		NO	
-----	--	----	--

If yes, please complete all the following Sections. If no, please complete Section 5 only

3. Details of substances pumped

3.1 Chemical names

(a) .....

(b) .....

(c) .....

(d) .....

3.2 Precautions to be taken in handling these substances

(a) .....

(b) .....

(c) .....

(d) .....

3.3 Action to be taken in the event of human contact

(a) .....

(b) .....

(c) .....

(d) .....

3.4 Cleaning fluid to be used if residue of chemical is found during servicing

(a) .....

(b) .....

(c) .....

(d) .....

Note: Please describe current faults .....

.....

.....

.....

4. I hereby confirm that the only substances(s) that the equipment specified has pumped or come into contact with are those named, that the information given is correct, and the carrier has been informed if the consignment is of a hazardous nature.

5. Signed .....

Name .....

Position .....

Date .....