

INSTRUCTIONS FOR USE

Machine Designation, Model variant
of a:

- 825 Pump or Pumphead
- 840 Pump or Pumphead



Date of publication: 12th of September 2024
Version of publication: PB0190 v5.02

ORIGINAL INSTRUCTIONS



0 Preface

0.1 Disclaimer

The information contained in this document is believed to be correct, but Watson-Marlow accepts no liability for any errors it contains and reserves the right to alter specifications without notice.

If the product is used in a manner which has not been specified in these instructions, then the protection provided by the equipment may be impaired.

0.2 Translation of the original instructions

This instruction handbook has originally been written in English. Other language versions of this instruction handbook are a translation of the original instructions.

Table of Contents

0	Preface.....	2
0.1	Disclaimer	2
0.2	Translation of the original instructions	2
1	Introduction: Document.....	6
1.1	Information types	6
1.2	Trademarks	7
1.3	Terminology.....	7
1.4	Abbreviations.....	7
2	Introduction: Product	8
2.1	General description	8
2.2	Intended use.....	9
3	Safety.....	10
3.1	Safety symbols.....	10
3.1.1	Instructions for renewing safety symbols.....	10
3.2	Safety devices	10
3.3	Safety signals	11
3.3.1	Signals: With risk of personal injury.....	11
3.3.2	Signals: With risk of equipment or property damage only	11
3.4	Personal protective equipment (PPE).....	12
4	Product overview	13
4.1	Pump models.....	13
4.1.1	Pumphead.....	14
4.1.2	Drive.....	22
4.2	Name plate	23
4.2.1	Product	23
4.2.2	Drive (Engineered Product)	23
4.3	Specification summary	25
4.3.1	Performance	25
4.3.2	Physical	25
4.3.3	Dimensions	26
4.3.4	Electrical power specification (EP)	27
4.3.5	Control (EP)	27
5	Storage	29
5.1	Storage conditions.....	29
5.2	Shelf life	29
6	Lifting and carrying	30
6.1	Product still in original packaging	30
6.1.1	Before lifting product.....	30
6.1.2	Lifting product.....	30
7	Unpacking your pump	31
7.1	Components supplied with your pump	31

7.2	Removing product from original packaging	31
7.3	Unpacking, inspection and packaging disposal	31
8	Installation: Chapter 1 (Physical)	33
8.1	Part 1: Physical installation requirements	33
8.1.1	Intended mounting (Frame Support)	33
8.1.2	Intended environment	33
8.1.3	Area around the product	34
8.1.4	Surface characteristics	35
8.2	Part 2: Physical Installation	36
8.2.1	Pre-physical installation checklist	36
8.2.2	Physical installation procedure	36
9	Installation: Chapter 2 (Electrical power)	37
9.1	Part 1: Power installation requirements	37
9.1.1	Power supply requirements	37
9.2	Part 2: Electrical power installation	39
9.2.1	Pre-electrical power installation requirement checklist	39
10	Installation: Chapter 3 (Control system Pumphead Guard Interlock)	40
10.1	Part 1: Control system installation requirements	40
10.1.1	Pumphead Guard Interlock	40
10.2	Part 2: Control system installation instructions	42
10.2.1	Pre-Control system installation checklist	42
10.2.2	Connect the pumphead door (guard) proximity sensor	42
10.2.3	Remaining control wiring	42
11	Installation: Chapter 4 (Fluid path)	43
11.1	Part 1: Fluid path system requirements	43
11.1.1	Overpressure safety device	43
11.1.2	Non-return valve	43
11.1.3	Isolation and drain valves	44
11.1.4	Inlet and discharge pipework	44
11.1.5	Piping vibration	44
11.2	Part 2: Fluid path installation	45
11.2.1	Pre-Fluid path installation requirement checklist	45
11.2.2	Prepare the pumphead and install the tubing element fluid path	45
12	Operation	51
12.1	Pre-operation checklist	51
12.2	Safety	51
12.2.1	Hazards that may occur during operation	51
13	Cleaning	53
13.1	Safety	53
13.2	Clean In Place (CIP)	53
13.3	Steam In Place (SIP)	54
14	Maintenance	55
14.1	Spare parts	55
14.2	Drive maintenance: restricted maintenance (EP)	57
14.2.1	Gearbox	57
14.2.2	Motor and motor mounted inverter	57

14.3	Pumphead maintenance.....	57
14.3.1	Tubing.....	57
14.3.2	Roller adjustment	64
15	Troubleshooting	65
15.1	Troubleshooting	65
15.1.1	Troubleshooting table	65
15.2	Technical support.....	66
15.2.1	Manufacturer	66
15.3	Warranty	67
15.3.1	Conditions	67
15.3.2	Exceptions	68
15.4	Returning pumps	68
16	Chemical compatibility	69
16.1	How to check chemical compatibility	70
16.1.1	Scenario A: Fluid Path (wetted by the pumped fluid in normal use)	70
16.1.2	Scenario B: Potential of being wetted due to environment or spillage	70
16.1.3	Scenario C: Potential of being wetted due to operating the tubing to the point of failure	71
17	Product specification and equipment ratings	72
17.1	Physical	72
17.1.1	Performance	72
17.1.2	Environmental and operating conditions	73
17.1.3	Dimensions	74
17.1.4	Weight	75
17.1.5	Ingress protection (IP Rating)	75

1 Introduction: Document

These instructions are the installation and maintenance instructions, for a Watson-Marlow 800 series pumphead or pump, for reference by a:

Responsible Person Individual responsible for the installation, maintenance, and safe use of the product by operators.

These instructions do not contain any operator instructions; The product is a partially complete machine, to be incorporated into a control system or final piece of equipment either of which must be independently designed, and certified (with the production of relevant operator instructions), by or on behalf of the user's organisation.

1.1 Information types

Specific non-safety information is presented throughout these instructions in the following format:

Model variations	These instructions cover multiple models. Where instructions apply only to specific models, brackets () are used.
Note	<p>A note is a piece of additional information to consider. A note is indicated by a ^{superscript}.</p> <p>Example:</p> <div style="border: 1px dashed black; padding: 5px;">NOTE ¹ Body text of note</div>

1.2 Trademarks

Watson-Marlow, 800 SERIES is a registered trademark of Watson-Marlow Limited.

1.3 Terminology

The following terminology is used in these instructions: This terminology is explained further when first relevant

Standard Product

An 825 or 840 pumphead and support frame, which is identical each time, manufactured by Watson-Marlow.

Engineered Product

An 825 or 840 pumphead, support frame, and attached drive unit which is manufactured by Watson-Marlow with custom features or specification

1.4 Abbreviations

The following abbreviations are used in these instructions:

EP	Engineered Product
HMI	Human Machine Interface
MSDS	Chemical Material Safety Data Sheet
PPE	Personal Protective Equipment
SP	Standard Product

2 Introduction: Product

2.1 General description

A Watson-Marlow 800 Series pump provides a flowrate of **fluid** by **positive displacement** through a tube element and fluid path.

A general illustration is provided below. Exact arrangement will vary by model (Engineered Product is shown):

1	Drive ¹
2	Pumphead
3	Location of tubing element

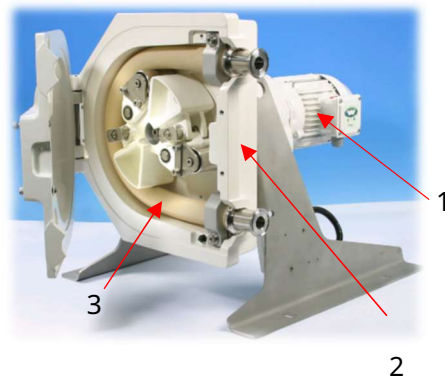

NOTE ¹

A drive unit is only included with an Engineered Product, as explained in section 4.1

2.2 Intended use

All model variants of the 800 series pumps are designed for the controlled movement of fluid, in ordinary safe locations, except those fluids or applications listed below as prohibited use.

Prohibited use:

- In patient-connected applications
- In an environment that requires explosion proof certification
- With fluids not chemically compatible ¹
- In installations, where there are environmental or operating conditions which are beyond the specifications provided in these instructions.
- Use of the pumphead without implementation of a suitable Guard Interlock ² function.
- Use of the pump without provision of a suitable emergency stop function.

NOTE ¹

A procedure for checking chemical compatibility is provided in section 16.

NOTE ²

The pumphead features a proximity sensor, which when connected to a control system can function as an emergency stop in safety applications up to Category 1, PL c /SIL 1 as defined by ISO 13849-1/IEC 62061.





A PL/SIL assessment must be carried out by a responsible person in the user or integrators organisation, to confirm the level of functional safety required.

3 Safety

This section provides general safety information for the safe use of the product. Safety information relevant to a specific task is provided when relevant to the task.

3.1 Safety symbols

The following safety symbols may be used on the product, packaging and in these instructions:

	Hot surface	This symbol indicates that the marked item can be hot and should not be touched without taking precautions
	PPE required	This symbol indicates Personal Protective Equipment must be worn prior to a task
	Hazardous voltage	This symbol indicates that hazardous voltages are present where a risk of electrical shock exists
	Rotating parts	Symbol indicates rotating parts which should not be touched without following a safety instruction
	Potential hazard	This symbol identifies that an appropriate safety instruction should be followed or a potential hazard exists

3.1.1 Instructions for renewing safety symbols

If product safety symbols suffer damage, contact your local Watson-Marlow representative for information on obtaining replacements.

3.2 Safety devices

The pumphead features a proximity sensor, which when connected to a control system can function as an emergency stop in safety applications up to category 1, SIL 1 as defined by ISO 13849-1, IEC 62061.

The Installed pump requires the implementation of a door (guard) interlock function along with provision of emergency stops to fulfil requirements of the Machinery Directive 2006/42/EC (CE/UKCA).

It is recommended that an evaluation/assessment is carried out to confirm the level of functional safety required.

3.3 Safety signals

Signals indicate a possible hazard.

3.3.1 Signals: With risk of personal injury

Signals indicating risk of a personal injury are presented when relevant to a task in this format:

WARNING

The WARNING signal word indicates a hazard. Risk of serious injury or death exists if the hazard is not avoided. Equipment or property damage may also occur.



A safety symbol indicates a hazard with personal injury risk.

Hazard information—Information to explain:

- Hazard type or nature of hazard
- What could happen
- How to avoid hazard

CAUTION

The CAUTION signal word indicates a hazard. Risk of minor or moderate injury exists if the hazard is not avoided. Equipment or property damage may also occur.



A safety symbol indicates a hazard with personal injury risk.

Hazard information—Information to explain:

- Hazard type or nature of hazard
- What could happen
- How to avoid hazard

3.3.2 Signals: With risk of equipment or property damage only

Signals indicating risk of equipment or property damage only are presented when relevant to a task in this format:

NOTICE

The NOTICE signal word indicates a hazard. Risk of equipment or property damage only.

Hazard information—Information to explain:

- Hazard type or nature of hazard
- What could happen
- How to avoid hazard



3.4 Personal protective equipment (PPE)

The following minimum PPE will be required during specific tasks:

1. Safety glasses
2. Safety boots
3. Gloves chemically compatible with the chemicals being pumped

A risk assessment by a responsible person must be undertaken to identify:

- Suitability of PPE for the application
- If additional PPE is required prior to use or for specific tasks

4 Product overview

4.1 Pump models

An 800 series pump is available in the following model variants:

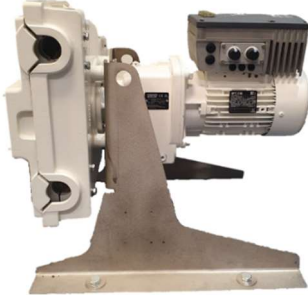
Standard Product (SP)	Engineered Product (EP) ¹
825 or 840 pumphead with support frame	Complete pump: 825 or 840 pumphead, with support frame, and drive (motor mounted inverter model shown)
	

NOTE ¹ Engineered products are bespoke products produced by Watson-Marlow. These products have custom features or specifications. Contact your Watson-Marlow representative to identify which features or specifications apply to your model

For the pump to provide a flowrate, a tubing element must be installed. A tubing element is a combination of a Watson-Marlow tube and connector set.

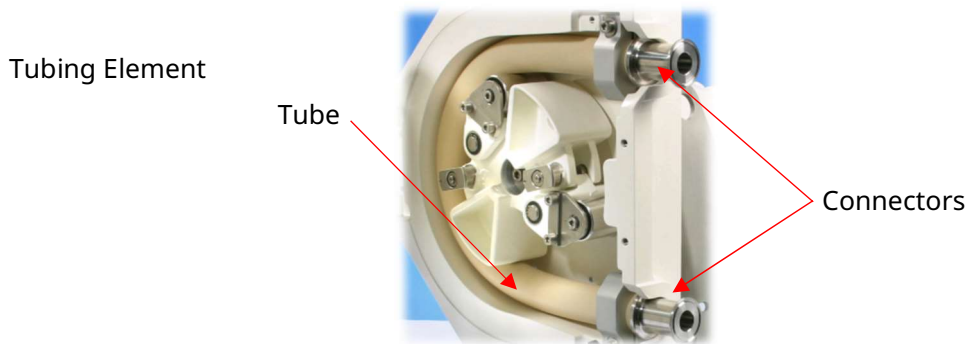

The combination of the Pumphead orientation, support frame, drive unit, and tubing element are configured to create a unique product model.

4.1.1 Pumphead

4.1.1.1 Pumphead variations

Pumphead model

825	For flowrates up to: 2,060 L/Hr
840	For flowrates up to: 8,140 L/Hr

General arrangement of Pumphead

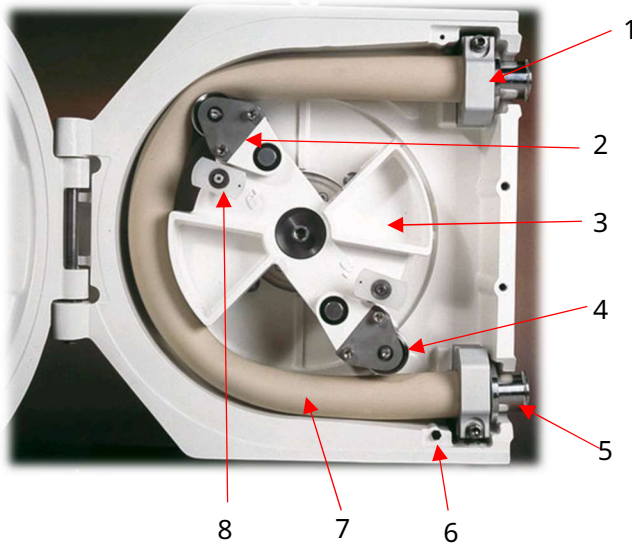

Item	Description	Quantity
1	Tube clamp	2
2	Rocker assembly	2
3	Rotor assembly	1
4	Roller assembly	2
5	Connector	2
6	Door proximity sensor	1
7	Tube element	1
8	Locking pin assembly	2

4.1.1.2 Engineered Options

800 Series pumpheads can be provided with or without support frames or drives. Both items can be installed using the following instructions.

4.1.1.3 To install a recommended Support Frame

Position support frames at rear face of pumphead and align support frame attachment holes with Pumphead attachment holes.

Place 1 x Bolt (1) through support frame into Pumphead, ensuring that 1 x Washer (2) and 1 x Washer (3) are fitted against the support frame.

Repeat process for remaining attachment hole.

Tighten Bolt (1) to 35.5Nm for 825 model and 61.3Nm for 840 model

Support to pumphead fixtures

Model	Item	Description	Model	Item	Description
825	1	4 x Bolt M10 x 25 HEX HD	840	1	4 x Bolt M12 x 30 HEX HD
825	2	4 x Washer M8 S.S	840	2	4 x Washer M12 S.S
825	3	4 x Washer M10 s/COIL SP	840	3	4 x Washer M12 s/COIL SP

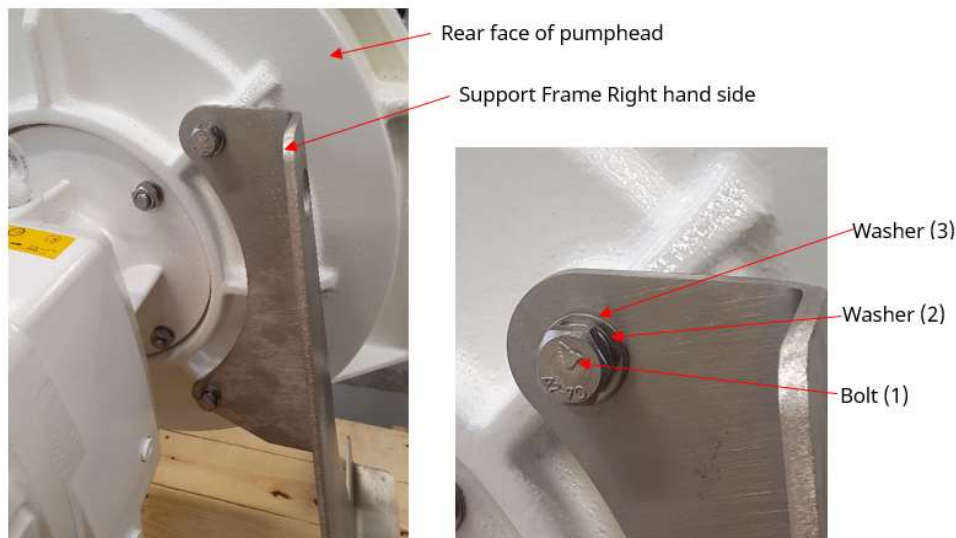

4 attachment points

4.1.1.4 Attaching a drive to pumphead

Preparing drive and Pumphead:

Before attaching a drive to the pumphead, ensure that it is of the correct specifications to allow the pumphead to operate correctly.

Ensure the pumphead is on a flat horizontal surface allowing sufficient room around it to carry out the necessary maintenance activities

Ensuring that all local lifting practices are adhered to and carried out by qualified personnel only.

Lift and position drive behind pumphead so that the drive shaft (3) aligns with hole (2) and the 4 drive attachment holes (4) in the pumphead (1).



CAUTION

Product is heavy. Suitable lifting aids are to be used to prevent crushing or trapping injuries. Ensure all lifting aids are in date for servicing. The correct PPE must be worn when carrying out lifting operations.

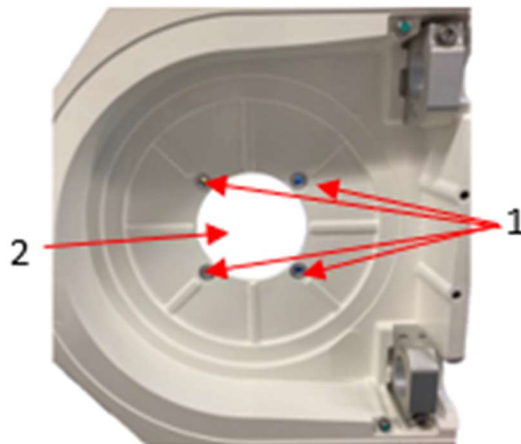

Drive to pumphead attachment fixtures

Model	Item	Description	Model	Item	Description
825	1	4 x Bolt M8 x 35 HEX HD	840	1	4 x Bolt M12 x 45 HEX HD
825	2	8 x Washer M8 S.S	840	2	8 x Washer M12 S.S
825	3	4 x Washer M8 s/COIL SP	840	3	4 x Washer M12 s/COIL SP
825	4	4 x Nut M8 HEX FULL GRA	840	4	4 x Nut M12 HEX FULL GRA

Attach Drive to pumphead:

1. From the front face of pumphead, place 1 x Bolt (1) and 1 x Washer (2) through pumphead face and drive plate attachment holes.
2. At the back of the pumphead and drive, fit 1 x Washer (2), 1 x Washer (3) and 1 x Nut (4) on to Bolt (1).
3. Repeat process for remaining attachment holes.
4. Tighten nut (4) to 39Nm for 825 and 100Nm for 840 model

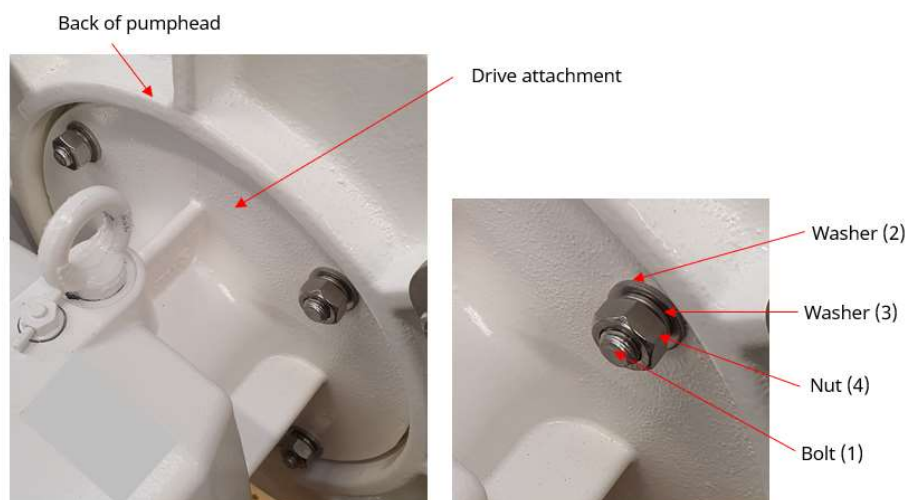
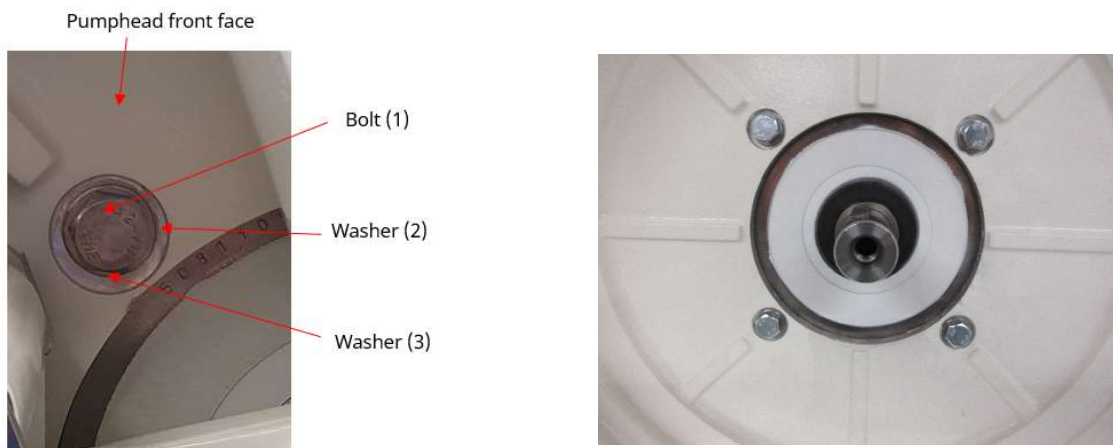

4.1.1.5 Attaching a rotor to driveshaft

Rotor to drive shaft attachment fixtures.

Model	Item	Description	Model	Item	Description
825	1	1 x Bolt M10 x 35 SKT	840	1	1 x Bolt M16 x 35 SKT
825	2	1 x Washer M10 s/Coil	840	2	1 x Washer M16 s/Coil
825	3	1 x Plate Washer M10	840	3	1 x Plate Washer M16
825	4	1x Shaft Collar	840	4	1x Shaft Collar

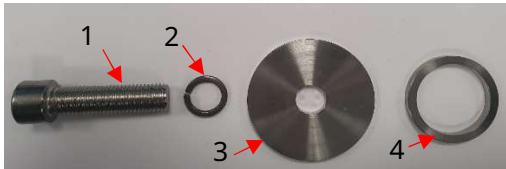

Attaching a rotor to a drive shaft:

1. Remove drive shaft keyway guide.

Drive shaft keyway guide



2. Fit spacer (4) onto drive shaft until it is fully seated against drive face.

Spacer



3. Replace drive shaft keyway guide.



4. Apply high temperature anti-seize grease to drive shaft.



5. Align keyway in rotor to guide on drive shaft.



6. Press rotor onto drive shaft until it is fully seated.



CAUTION

Keep fingers clear from back of rotor to prevent crushing injuries or cuts

7. Fit large plate washer (3), spring washer (2) and bolt (1) into drive shaft.



8. Tighten securing bolt (1) to 20Nm for 825 model and 100Nm for 840 model.

Fixtures supplied for attaching drive to Pumphead:

Model	Item	Description	Model	Item	Description
825	1	4 x Bolt M8 x 35 HEX HD	840	1	4 x Bolt M12 x 45 HEX HD
825	2	8 x Washer M8 S.S	840	2	8 x Washer M12 S.S
825	3	4 x Washer M8 s/COIL SP	840	3	4 x Washer M12 s/COIL SP
825	4	4 x Nut M8 HEX FULL GRA	840	4	4 x Nut M12 HEX FULL GRA

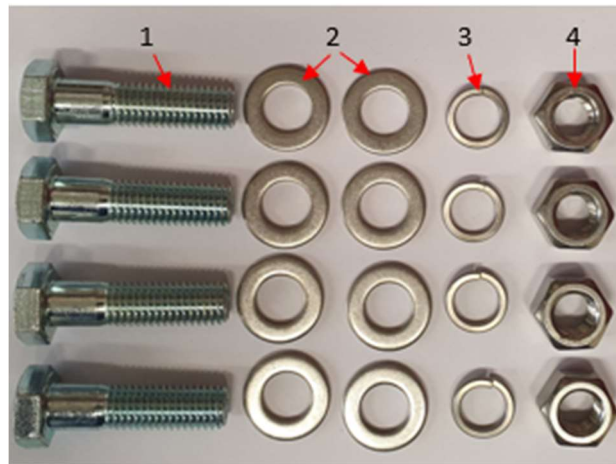

Fixtures supplied for attaching rotor to drive shaft:

Model	Item	Description	Model	Item	Description
825	1	1 x Bolt M10 x 35 SKT	840	1	1 x Bolt M16 x 35 SKT
825	2	1 x Washer M10 s/Coil	840	2	1 x Washer M16 s/Coil
825	3	1 x Plate Washer M10	840	3	1 x Plate Washer M16
825	4	1x Spacer	840	4	1x Spacer

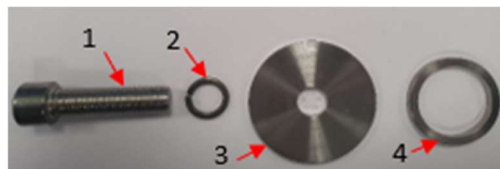

4.1.1.6 Tubing

Tubing is available in two materials:

- Bioprene
- Sta-Pure

Pressure and temperature ratings:

Model	Description	Bar	Temperature
825	Bioprene tubing element	2 Bar	5°C-80°C (41°F to 176°F)
825	Bioprene tubing element 2.3m length	2 Bar	5°C-80°C (41°F to 176°F)
825	Bioprene tubing element	3.5 Bar	5°C-80°C (41°F to 176°F)
825	Bioprene tubing element 2.3m length	3.5 Bar	5°C-80°C (41°F to 176°F)
825	STA-PURE high pressure tube element	3.5Bar	-20°C-80°C (-41°F to 176°F)
840	Bioprene tubing element	2 Bar	5°C-80°C (41°F to 176°F)
840	Bioprene tubing element	3.5 Bar	5°C-80°C (41°F to 176°F)

4.1.1.7 Connectors

Available connectors.

Model	Description
825	Triclamp Hygienic connector
825	SMS Hygienic connector
825	Quick Coupling
840	Triclamp Hygienic connector
840	RJT (BS 1864) Hygienic connector

Part numbers for tubing and connectors are available in Section 14.1.

4.1.2 Drive

4.1.2.1 General arrangement of drive

The general arrangement of the drive is provided below: An Engineered Product with motor mounted inverter is shown - the exact arrangement will depend on model.

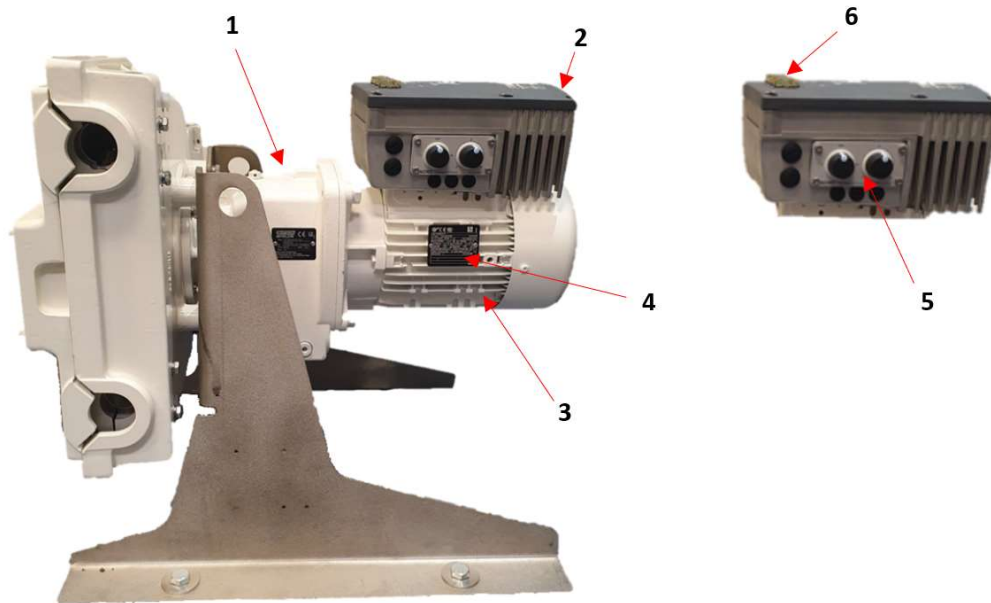

Figure number	Description
1	Gearbox
2	Inverter
3	Motor
4	Motor nameplate
5	Motor mounted inverter (optional) with local control (option)
6	Motor mounted inverter: Remote Control/DIP Switches/LED Diagnostic Ports options

4.2 Name plate

4.2.1 Product

Nameplate is fixed to the pumphead.



4.2.2 Drive (Engineered Product)

4.2.2.1 Motor

The electric motor nameplate is fixed to its body. It will vary, dependent on the model.

Example of a name plate shown below:

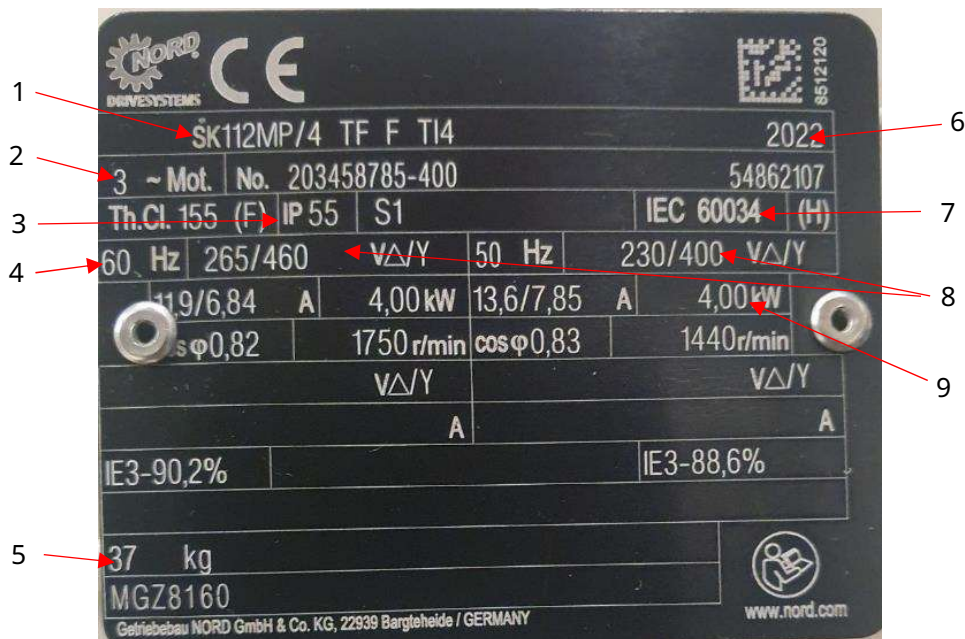

Item	Description	Item	Description
1	Model type	6	Year of manufacture
2	Number of phases	7	Conformity specifications
3	IP protection class	8	Duty voltage
4	Stator Frequency	9	Nominal power
5	Weight		

4.2.2.2 Motor mounted inverter (Optional)

The inverter nameplate is fitted on top of the inverter. It will vary dependent on the inverter model.

Example of a name plate shown below:



Item	Description
1	Manufacturers details
2	Model/version details
3	Operating and protection specifications
4	Conformity specifications
5	Hazard warnings

4.3 Specification summary

This section provides a summary specification for the purposes of an overview. Detailed information is provided in Section 17

4.3.1 Performance

4.3.1.1 Flowrate

The flowrate of the pump is a combination of pumphead speed, and application (pressure, fluid viscosity). Flowrates are based on pumping water at 20°C with a 0-bar g inlet and discharge pressure, represented in the performance graphs below:

825

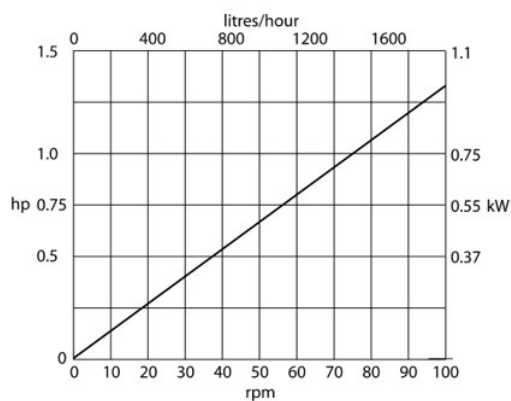

840

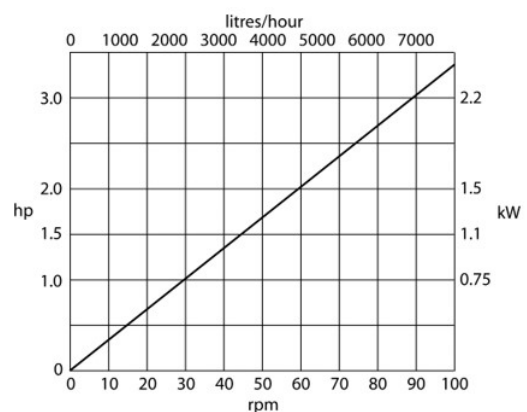

4.3.2 Physical

4.3.2.1 Environmental and operating conditions

	Pumphead and support (SP)	Engineered Product (EP)
Ambient temperature range	5 °C to 40 °C (41 °F to 105.0 °F)	Refer to drive instructions
Maximum altitude	≤2000 m, (6561.6 ft)	Refer to drive instructions
Pollution degree of the intended environment	2	Refer to drive instructions
Noise	<75 dB(A) at 1 m	Refer to drive instructions
Maximum fluid temperature ¹	80°C (175 F)	
Environment	Indoor	Refer to drive instructions

NOTE ¹

Chemical compatibility is dependent on temperature. A procedure for checking chemical compatibility is provided in section 16

4.3.3 Dimensions

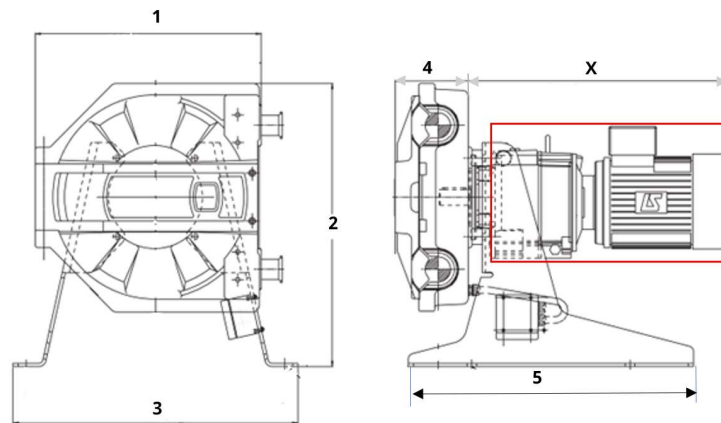

Model	1	2	3	4	5	X
825	428mm (16.85")	535mm (21.06")	540mm (21.26")	145mm (5.7")	540 mm (21.2")	Note1
840	649mm (25.5")	779mm (30.6")	790mm (31.1")	208mm (8.1")	640 mm (25.2")	Note1

NOTE 1

Dimension X is dependent on the size of drive selected (outlined in red).

4.3.3.1 Weight

Nominal weight of Pumps ¹	
825 Series	840 Series
100 kg (220 lb)	175 kg (385 lb)

NOTE 1

Weight depends upon the drive model fitted

4.3.3.2 Ingress protection

Pumphead and support (SP) No IP rating

Pumphead, support and drive (EP) IP rating of drive is dependent upon the drive and inverter which is fitted. IP55 is standard with an option for IP66.

4.3.4 Electrical power specification (EP)

The electrical power requirements is dependent on the drive which may be installed on the pump. The power requirement information is provided on the motor name plate. If a motor mounted inverter is fitted, refer to the Inverter name plate.

4.3.5 Control (EP)

The following control methods are available.

Control methods	825 Variable speed	840 Variable Speed
Remote Operation	✓	✓
Local Operation Only	✓	✓
Local/Remote Operation	✓	✓
Local Control by HMI	✓	✓

Please contact your Watson-Marlow representative to determine which features your pump has.

4.3.5.1 Control panel overview (EP: Local control models)

A local control option can be fitted to some models.

Example of a Nord Inverter (SK-CU4-POT) with the local control option provided below:

1	On Left-Off-On Right	
2	Variable potentiometer 0-10% (Speed adjustment)	

4.3.5.2 Control panel overview (EP: Remote control models)

A remote-control facility is available on some models.

Example of a NORD inverter is provided below:

1	Diagnostic LEDs	
2	DIP switch	
3	Remote control/Diagnostic/Programming connection	



4.3.5.3 PROFIBUS DP Inverter Interface Option

NORD Profibus SK CU4-PBR, Specifications:

Version: Protocol: DPV0, DPV1

Baud Rate: Maximum 12 MB/s

Profibus

2 digital Inputs

LED: 2 Status and 2 Failure

5 Storage

5.1 Storage conditions

Storage of the pump and tube elements should be carried out in accordance with the following:

Pump

1. Storage temperature range: -40 °C to 70 °C (-40 °F to 158 °F)
2. Indoors, cool, and dry
3. Not in direct sunlight
4. In original packaging

Tube Element

1. Storage temperature range: 5 °C to 40 °C (40 °F to 86 °F)
2. Indoors, cool, and dry
3. Away from direct sunlight
4. In original packaging

5.2 Shelf life

800 Series Tube Elements have a shelf life of 5 years from date of manufacture.

Shelf life can be affected by storage conditions.

Use by date is marked on packaging label.

6 Lifting and carrying



CAUTION

Risk of injury and equipment damage. The pump weighs up to 175 kg (385lb) depending upon model. Suitable lifting aids are to be utilised. The weight of the pump could cause a foot injury if dropped. The correct safety equipment is to be worn when lifting and moving the pump.

6.1 Product still in original packaging

If unpacking product before lifting, see Section 7 before continuing.

6.1.1 Before lifting product

1. Observe, any symbols on packaging. Such as the upright symbol 
2. Ensure that crate is positioned on a flat horizontal surface
3. Use suitable lifting aids in accordance with local health and safety procedures, always keeping the product upright.

6.1.2 Lifting product

If lifting product and pallet with a forklift:

1. Take note of the products centre of gravity on the pallet.

If lifting product from pallet:

1. Use a suitably rated lifting aid
2. Use lifting point shown in picture
3. Never exceed the maximum rating of the lifting equipment



WARNING

Product is heavy. Suitable lifting aids are to be used to prevent crushing injuries or death. Ensure all lifting aids are in date for servicing. The correct PPE must be worn when carrying out lifting operations.

Nominal Weights:

825; 100kg (187lb) 840; 175kg (385lb)

7 Unpacking your pump

7.1 Components supplied with your pump

The following components are supplied with the pump/pumphead.

1. Allen Key ,10 mm for 840 or 6 mm for 825.
2. Tube Element, supplied fitted to pump.
3. Relevant manufactures manuals.

7.2 Removing product from original packaging

Procedure

1. Remove crate lid
2. Remove all four sides of crate



7.3 Unpacking, inspection and packaging disposal

Procedure

1. Carefully remove all parts from the packaging.
2. If lifting and carrying product, refer to Section 6
3. Check that all components in Section 7.1 are supplied.
4. Inspect components for damage caused in transit.
5. If anything is missing or damaged, contact your Watson-Marlow representative immediately.
6. Dispose of the packaging according to local procedures.
 - Outer crate: Plywood (recyclable)



Installation

Installation is provided in the following order.

1. Installation: Chapter 1 (Physical)
2. Installation: Chapter 2 (Electrical power)
3. Installation: Chapter 3 (Control system)
4. Installation: Chapter 4 (Fluid path)

Follow the installation in the specific order above. to ensure that hazards are minimised.

Each of the chapters, are divided into two main parts. Each part will provide chapter specific information in the following order:

1. Part 1: Installation requirements
2. Part 2: Installation instructions and testing

8 Installation: Chapter 1 (Physical)

8.1 Part 1: Physical installation requirements

8.1.1 Intended mounting (Frame Support)

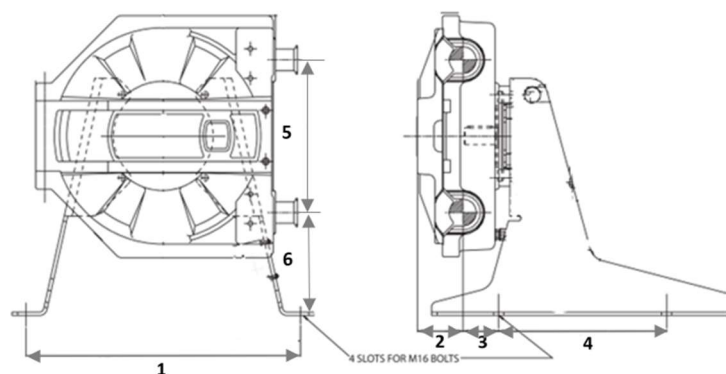

Model	1	2	3	4	5	6
825	490mm (19.29")	81mm (3.91")	64mm (2.52")	300mm (11.81")	272mm (10.71")	184mm (7.24")
840	730mm (28.74")	118mm (4.65")	90mm (3.54")	380mm (14.96")	450mm (17.72")	239mm (9.41")

8.1.2 Intended environment

The product must be installed such that no part of the pump may exceed the environment limits provided below:

	Pumphead and support (SP)	Engineered Product (EP)
Ambient temperature range	5 °C to 40 °C (40 °F to 105 °F)	Refer to drive instructions
Maximum altitude	≤2000 m, (6561ft)	Refer to drive instructions
Pollution degree of the intended environment	2	Refer to drive instructions
Noise	<75 dB(A) at 1 m	Refer to drive instructions
Maximum fluid temperature ¹	80°C (175 F)	
Environment	Indoor	Refer to drive instructions

NOTE ¹

Chemical compatibility is dependent on temperature. A procedure for checking chemical compatibility is provided at Section 16.

8.1.3 Area around the product

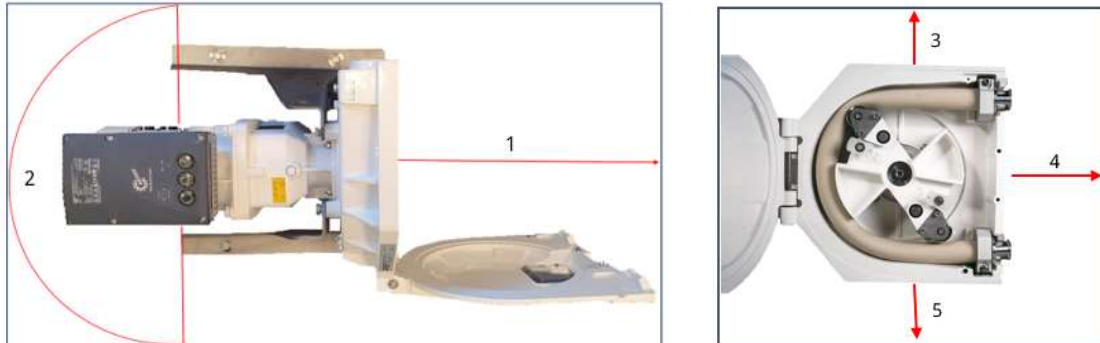

The pump must always be accessible to facilitate the following

Number	Comment	Suggested Distance
1	Clearance for door to open fully during maintenance and cleaning	825: 500mm 840: 700mm
2	Allow sufficient room for airflow and access for maintenance, cleaning, and programming	1m
3	Allow sufficient head room for access and airflow	1m
4	Straight fluid path tubing minimum length	0.5m minimum
5	Set to allow comfortable working height for operators	Set by user

8.1.4 Surface characteristics

The pump must be installed as follows in accordance with the instructions below:



Ensure that:

Pump is on a flat horizontal surface



CAUTION

Pump must be on a flat horizontal surface to prevent it from tipping over and causing crushing injuries or cuts and abrasions.

With a frame support suitable to:

1. Ensure that the fluid path connections have adequate space to be installed and removed.
2. Ensure the pump is at a comfortable height for operation

Surface is rated to support full weight of complete assembly and pumped product

Chemically compatible with the fluids being pumped

Free of vibration

NOTICE

Risk of equipment damage due to vibration. Install the pump on a surface free from excessive vibration.

8.2 Part 2: Physical Installation

8.2.1 Pre-physical installation checklist

Carry out the following pre-installation checklist prior to following the installation procedure below:

- Ensure all sections of Part 1 of the physical installation requirements have been met
- Ensure that M16 anchor bolts are available (use Grade 5.6 bolts as a minimum)
- Ensure a torque wrench capable of 100 Nm is available
- Ensure the pump has not yet been connected to any electrical or control cables.

If there is a problem with any of the above, do not proceed to the physical installation procedure until the problem has been resolved.

8.2.2 Physical installation procedure

8.2.2.1 Mounting procedure

1. Mark required anchoring holes in suitable surface using dimensions at 8.1.1.
2. Drill holes to accommodate M16 anchor bolts.
3. Clean the bore holes.
4. Insert M16 anchor bolts into bore.
5. Tighten M16 anchor bolts to secure product.

9 Installation: Chapter 2 (Electrical power)

This chapter is for electrical power installation for Engineered Products only.

9.1 Part 1: Power installation requirements

9.1.1 Power supply requirements

9.1.1.1 Standard Products

Drive units

Pumphead, with support frames will require a drive unit with the following specification. Contact your Watson-Marlow representative for more information.

825 & 840 Series IE3 motors Integrated with Nord SK Inverter (5-50Hz)
 230/400V 3ph IP55. (Example Model No.VIB/R)

Pump	Motor Power	rpm @ 5-50Hz	Pump	Motor Power	rpm @ 5-50Hz
825	0.55 kw	2-16	840	0.55 kw	1-11
825	0.55 kw	2-26	840	0.75 kw	2-19
825	0.75kw	3-31	840	1.1 kw	3-25
825	0.75kw	4-40	840	1.1 kw	3-31
825	1.1kw	5-49	840	2.2 kw	5-44
825	1.1kw	6-60	840	2.2 kw	7-63
825	2.2kw	9-87	840	3.0 kw	7-71
825	2.2kw	10-99	840	4.0 kw	10-95

Example "Generic" Integrated NORD SK Invertor control configurations possible for variable speed pumps. (Example Model No. 825/840 VIB/R)

	Control Configuration:	Description
1.	Remote Operation	Blank plate
2.	Local Operation ONLY	Speed control knob (0-10) and on-R/off/On -L switch e.g., SK-CU4 POT
3.	Local / Remote Operation	Speed control knob (0-10) and on -R/off/On-L switch plus extra key switch to enable/disable local control e.g., Local/Off/Remote or Hand/Off/Auto
4.	Local Control by HMI	Local control by HMI Local keypad installed on invertor e.g., Parameter box SK PAR-3H

9.1.1.2 Engineered Products

Drive units

Complete pumps supplied by Watson-Marlow are bespoke with custom specifications. Refer to name plate on the motor or inverter if this model is supplied.

Power supply

The power supply must meet the following additional requirements for UK, EU member states, Norway, Switzerland and Turkey:

A/C Supply Voltage/frequency	3 Phase 230/400 V 50 Hz
overvoltage category	III
Maximum voltage fluctuation	±10 % of nominal voltage

If the quality of the AC supply cannot be guaranteed, we recommend the use of appropriate commercial electrical supply stabilising equipment.

9.1.1.3 Protection device

Use an appropriate and suitably rated protection device, such as a ground fault circuit interrupter (GFCI), Residual Current Device (RCD) or branch circuit protection device. For more information consult the fitted drives manufacturer's instructions.

9.1.1.4 Electrical isolation

The product does not come with an external supply isolation device. An electrical power supply isolation device must be included in the electrical power circuit and be easily accessible. For more information consult the fitted drives manufacturer's instructions.

9.1.1.5 Cable (wiring) specification

A power cable is not supplied with this product and Watson-Marlow are unable to give a recommendation on the supply cable size. The electrical installer should be consulted for the correct cable size to be used. The supply cable should be suitable for the operating environment, power supply and geographical legislation.

9.2 Part 2: Electrical power installation

9.2.1 Pre-electrical power installation requirement checklist

Prior to electrical power installation, carry out the following pre-installation checks to ensure that.

- The pump has been physically installed in accordance with section 8
- The pump has a suitable drive unit installed (section 9.2.1)
- An electrical isolation device is installed in an easily accessible location and ready for use.
- Overcurrent protection is installed and ready for use.
- Power cables to be used are specified for the operating environment and rated to carry the required electrical power
- The pumphead door is shut, and tool locked.
- The fluid path to the pump has not yet been installed

If there is a problem with any of the above, do not carry on with the electrical installation and ensure that the pump is removed from service until resolved.

9.2.1.1 Connect to AC Power supply

- Check that the pre installation checks are correct.
- Ensure the power supply has been isolated.
- Consult the drive unit instructions for electrical power connection installation information.
- Connect to AC power supply.



WARNING

Risk of chemical injury from the fluid path. As soon as power is supplied, the pump may operate (based upon start up defaults), resulting in possible accidental pumping of a fluid. Do not install the fluid path out of chapter sequence.

9.2.1.2 Earth continuity testing

Refer to the drive unit instructions, for information on carrying out an earth continuity test.

10 Installation: Chapter 3 (Control system Pumphead Guard Interlock)

10.1 Part 1: Control system installation requirements

10.1.1 Pumphead Guard Interlock

The installed pump requires the implementation of a pumphead guard (door) interlock function.

10.1.1.1 Pumphead Guard Sensor Specifications:

General Specifications	
Switching function	Normally open (NO) when guard is open
Output type	Two-wire
Rated operating distance	S _n 2 mm
Installation	Flush
Output polarity	DC
Nominal ratings	
Operating voltage	U _B 5...60 V
Switching frequency	f 0...800 Hz
Reverse polarity protection	Reverse polarity tolerant
Short circuit protection	Pulsing
Voltage drop	U _d ≤ 5 V
Operating current	I _L 2...100 mA

The single pumphead guard (door) proximity sensor when used in conjunction with an inverter digital stop input is suitable for a category 1, SIL1, PLC safety function.

10.1.1.2 Pumphead Guard Sensor Functional Safety Parameters are:

Functional safety related parameters	
MTTF _d	2090a
Mission time (T _m)	20a
Diagnostic coverage (DC)	0%

10.1.1.3 pumphead guard (door) proximity sensor connection.

The pumphead guard (door) proximity sensor requires connecting to the inverter by the user.

Below is an example of a single pumphead guard (door) proximity sensor connection to a NORD SKZ00E frequency inverter digital stop input

Pumphead Guard (Door) Proximity Sensor
Category 1 : SIL 1 , PL c , Wiring Example only

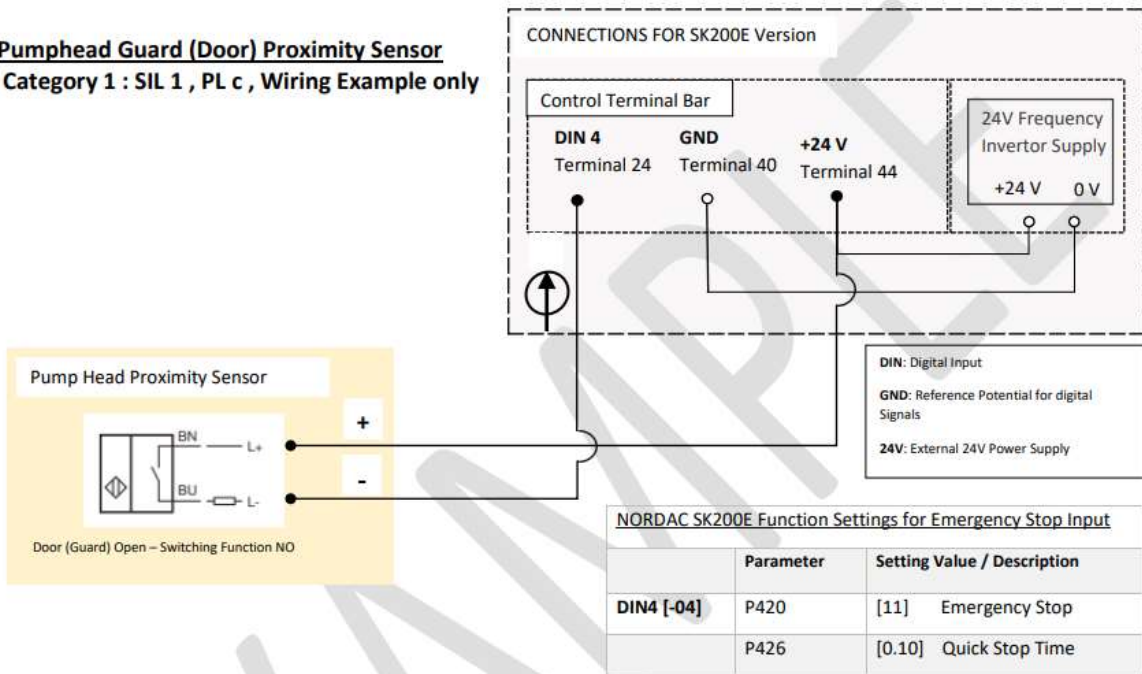

10.2 Part 2: Control system installation instructions

10.2.1 Pre-Control system installation checklist

Carry out the following pre-control installation checks to ensure.

- The pump has been physically installed in accordance with Section 8
- The pump has been electrically installed in accordance with section 9
- The fluid path to tubing element connections have not yet been made.

If there is a problem with any of the above do not carry on with the fluid path installation and ensure that the pump is removed from service, until the pre-fluid path installation requirements have been met.

10.2.2 Connect the pumphead door (guard) proximity sensor

Connect proximity sensor to the safety related control system.

10.2.3 Remaining control wiring

Connect the remaining control interface using the instructions supplied with the fitted integral inverter.

11 Installation: Chapter 4 (Fluid path)

11.1 Part 1: Fluid path system requirements

A Watson-Marlow pump should be installed into a fluid path system with specific ancillary devices to ensure safe operation. These requirements are detailed in the sections below. All devices, connections or pipework must be:

- Chemically compatible with the pumped fluid.
- Have a specification rating higher than that of the application.

11.1.1 Overpressure safety device

A Watson-Marlow pump operates by **positive displacement**. Should a blockage or restriction occur, the pump will continue to operate until either of the following occur:

- The pumphead element, or ancillary device rupture, leak, or otherwise fail
- The fluid path pipework or ancillary device rupture, leak, or otherwise fail
- The drive fails.

Install an overpressure safety device which can automatically activate. This device should:

- Be able to be set to a pressure lower than the pressure rating of the system.
- Be able to stop the pump or divert fluid to a safe location when triggered.
- Have a failsafe feature.
- Relief valve shall be capable of passing maximum flow produced by the pump as installed.

11.1.2 Non-return valve

Install a non-return valve in the inlet and discharge fluid path as close as possible to the pumphead in the following scenarios:

- Applications where there is a positive inlet or discharge pressure exceeding 0.5 bar (7psi) acting upon the pump when the pump is stopped. In the event of tubing failure, this positive pressure will result in the continued flow of pumped fluid into the pump head and surrounding area.
- Applications where the pressure of 0.5 bar (7psi) is not exceeded, but the flow of fluid in the event of tubing failure would result in a hazard

This is to prevent pressurised chemical backflow in the event of a pumphead, tube or element failure. If the pump is to be operated in reverse, the non-return valve will need to be bypassed during this operation, to avoid becoming a blockage.

11.1.3 Isolation and drain valves

Isolation and drain valves must be installed in the fluid path in the following scenarios:

- Where tubing replacement or removing a pump from service, requires the fluid to be drained in such a volume that the users drain vessel would not be able to contain the volume of liquid in the system. For example, in small volume, long single use tube applications, this may not be necessary.
- The tube element replacement procedure requires the fluid path to be isolated, and parts of the fluid path drained prior to being disconnected.
- Other procedures require the pump to be removed from service, such as due to a fault. This will require the isolation and draining of parts of the fluid path.
- Where it would cause a hazard
- Peristaltic pumps are self-sealing in some circumstances. However, there can be flow through the pumphead due to wear of components causing a potential hazard.

Ensure valve is opened before the pump operate and closed before the pump is stopped.



WARNING

Failure to open and close an isolation valve prior to pump operation would create an overpressure event, leading to serious injury or burns.

11.1.4 Inlet and discharge pipework

Inlet and discharge pipes should:

- Be as short and direct as possible
- Use bends of large radius
- Use the largest diameter bore tube that will fit with your process.

11.1.5 Piping vibration

A Piping Vibration and Integrity Assessment (piping vibration audit) should be undertaken.

11.2 Part 2: Fluid path installation

11.2.1 Pre-Fluid path installation requirement checklist

Carry out the following pre-fluid path installation check to ensure.

- The pump has been physically installed in accordance with section 8
- The pump has been electrically installed in accordance with section 9
 - In addition:
 - Ensure the power cable is not damaged
 - Ensure the electrical isolation device is fitted and working
- The pumps control system has been set up in accordance with section 10
- The door (guard) interlock is connected and working.
- All requirements for the fluid path (Part 1) in this section have been met

If there is a problem with any of the above do not carry on with the fluid path installation and ensure that the pump is removed from service, until the pre-fluid path installation requirements have been met.

11.2.2 Prepare the pumphead and install the tubing element fluid path

Products may be supplied with or without the tubing element installed by Watson-Marlow at time of manufacture. This is at the customer request at time of order.

If the tubing element is already installed this installation section may be disregarded.



Tubing Element Installed

11.2.2.1 Prepare the pumphead

Refer to Figure 1 when rocker assemblies are to be locked or unlocked

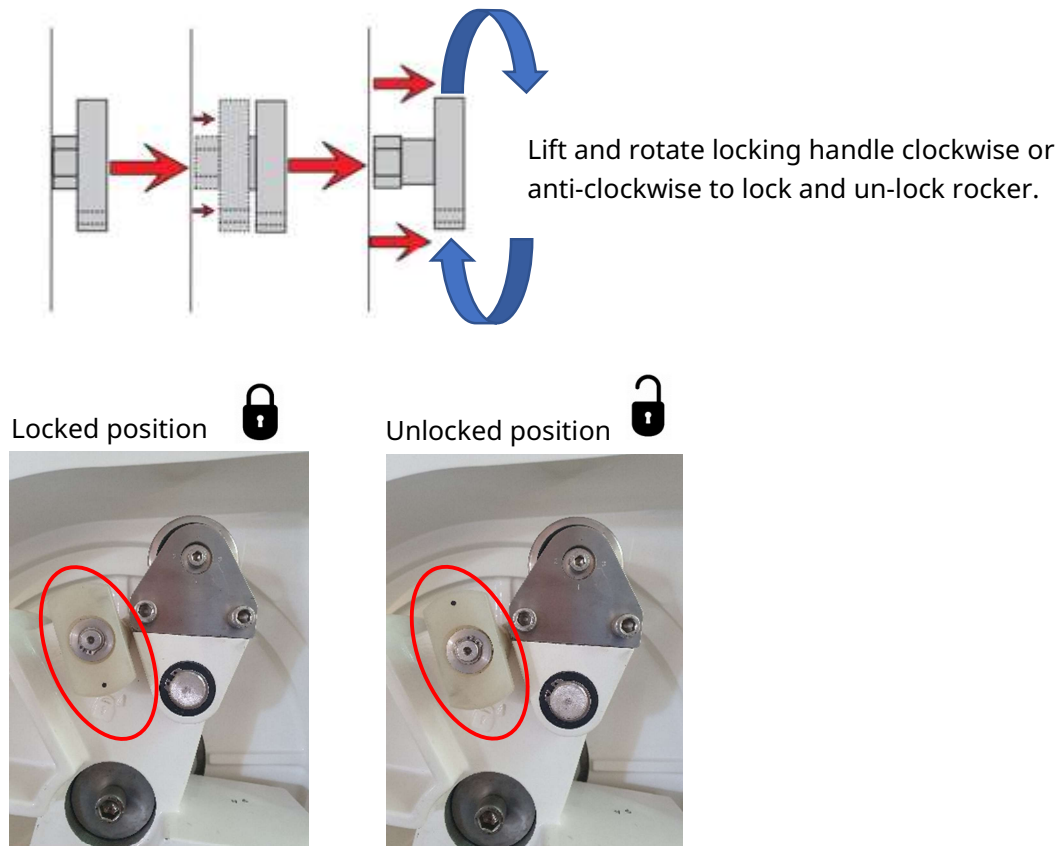

Figure 1

Refer to Figure 2 when rotor assembly requires rotating.



CAUTION

The rotor must only be rotated using the recesses as shown to prevent crushing/trapping injuries or cuts and abrasions

Figure 2

Refer to Figure 3 when rocker assemblies are moved.



CAUTION

Never place hands on outer edge of rotor near the rocker assemblies or rocker pin to prevent crushing/trapping injuries or cuts and abrasions

Figure 3

11.2.2.2 Install a tube element

To install a tube element, use the following procedure:

1. Ensure the drive is isolated from power supply.
2. Open pumphead door, using the correct allen key.



3. Undo upper and lower tube clamps (1).

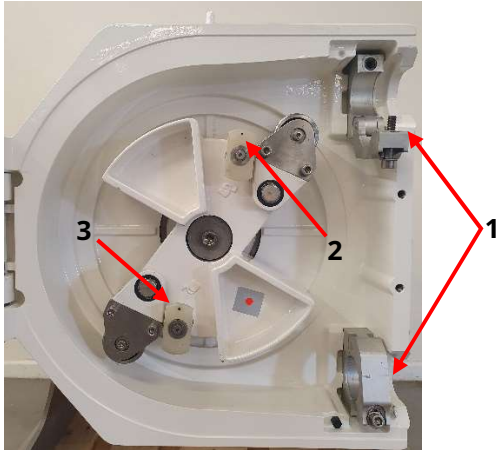

4. Rotate rotor to position shown using casting recesses (refer to figure 2).



CAUTION

The rotor must only be rotated using the recesses as shown to prevent crushing/trapping injuries or cuts and abrasions

5. Check that lower rocker assembly (3) is locked in engaged position.
6. Unlock upper rocker assembly (2) (refer to figure 1).

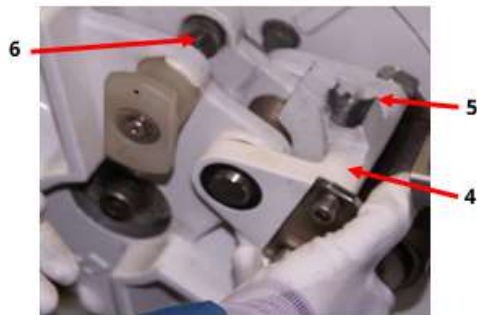

7. Holding roller-mount (4) as shown, pull rocker assembly (5) clear of locking pin (6).



CAUTION

Never place hands on outer edge of rotor near the rocker assemblies or rocker pin to prevent crushing/trapping injuries or cuts and abrasions

8. Turn locking pin assembly (6) to locked position (refer to figure 1).
9. Gently allow rocker assembly (5) to return until it rests on locking pin assembly (6)
10. The rocker assembly is now disengaged and free to retract when rotating the rotor anti-clockwise during tube element loading.



11.2.2.3 Construct a new tube element

Insert a coupling into both ends of a new section of tubing as shown below.

Ensure that the coupling butts against the element end



11.2.2.4 Installing a tube element

1. Locate tube coupling into upper clamp, ensuring coupling sits correctly in track groove then hand tighten clamp.

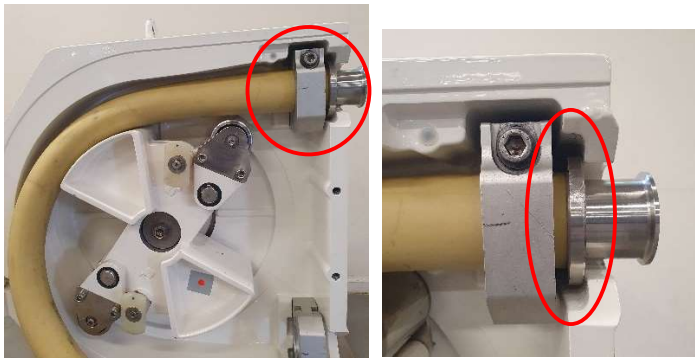

CAUTION

Ensure that coupling is locked into clamp before bending tube. Movement can cause, Impact or striking injuries, abrasions, and cuts.

2. Feed tubing into track whilst rotating rotor anti-clockwise using the casting recesses



CAUTION

The rotor must only be rotated using the recesses as shown to prevent crushing/trapping injuries or cuts and abrasions

3. Slowly rotate anti-clockwise until lower tube coupling is located into the lower clamp (1) ensuring coupling sits correctly in track groove then hand tighten clamp.
4. The locked, disengaged rocker assembly (2) should be in position shown.
5. The rotor is prevented from rotating further by the locked, engaged rocker assembly (3)

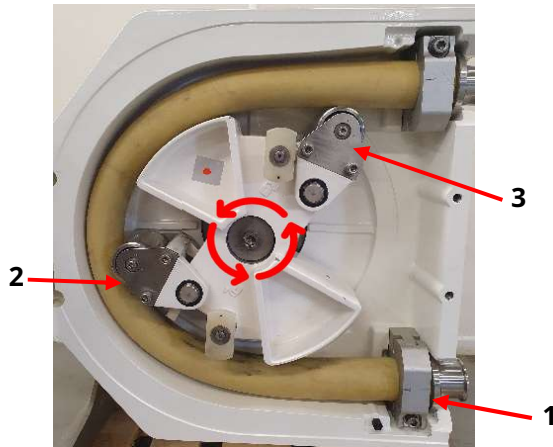

6. Securely fasten upper and lower clamps.
7. Once tube is secured, the lower rocker assembly (2) will be held in the retracted position by the tube.
8. Rotate rocker locking pin assembly to the unlocked position (refer to figure 1)
9. This allows rocker assembly (2) to return to the engaged position when rotor is rotated.
10. Because the upper rocker assembly (3) is locked, and engaged, it will not be possible to rotate the rotor by hand.
11. To engage the lower rocker assembly (2) it is necessary to rotate the rotor with power on.
12. Close and secure the pumphead door and reconnect power supply
13. Turn on the drive and rotate rotor clockwise until the unlocked rocker assembly is engaged in position (audible sound when this happens)
14. Isolate the drive from power supply and open the pumphead door.
15. Rotate locking pin assembly into the locked position (refer to figure 1)



16. Check that both rocker assemblies are locked into the engaged pumping position
17. Close the pumphead door and tool tighten door screws.

12 Operation

These instructions contain limited operator instructions; The product is a partially complete machine, to be incorporated into a control system or final piece of equipment either of which must be independently designed, and certified (with the production of relevant operator instructions), by or on behalf of the user's organisation.

The following information is provided to assist the user with the preparation of operation instructions:

12.1 Pre-operation checklist

A pre-operation checklist should consider the following points to ensure:

- The pump has been physically installed in accordance with Section 8
- The pump has been electrically installed in accordance with section 9
- The pumps control system has been set up in accordance with section 10
- The fluid path has been installed in accordance with section 11
- Ensure the pumphead door is closed
- Check for leaks from any connections when the pump is stationary

If there is a problem with any of the above or is any doubt that the installation of the pump has not been completed and tested, then do not proceed to operate the pump. Ensure that the pump is removed from service until the full installation is complete.

12.2 Safety

12.2.1 Hazards that may occur during operation.

The following hazards may occur during operation of the pump.

12.2.1.1 Unexpected operation

Pump models which are controlled by a remote-control system, may operate unexpectedly in response to a control system input.

12.2.1.2 Risk of burns

Pump and fluid can get hot during operation



CAUTION

Risk of injury due to burns. The exterior of the pump can get hot during operation. Stop the pump and let the pump cool before handlings

12.2.1.3 Dry running

The pump can be run dry for short time periods, such as during priming (air bubbles) or when there is fluid with pockets of gas.

NOTICE

Risk of damage to the pump. The pump is not designed to be run dry for extended periods of time. Dry running will generate excessive heat. Do not run the pump dry for extended period

12.2.1.4 Pump Operation

The peristaltic pump is a rotary type positive displacement pump, using rotary parts to move fluid

The pumping chamber is a continuous length of flexible tubing set in a U-shaped housing and the motion of the pump rollers "occludes" the inner walls of the tubing and forces fluid through the pump.

12.2.1.5 Bi-directional Pumping

The 800 Series pump is designed to be operated in a clockwise direction

For operation in the clockwise direction, it is not necessary to lock the rollers for tube element occlusion.

However, an 800 series pump can also be operated in the anti-clockwise direction for a reverse fluid flow.

For bi-directional pumping e.g., operation in clockwise and anti-clockwise direction, the rollers **MUST** be locked for the tubing element to be occluded in the anti-clockwise direction.

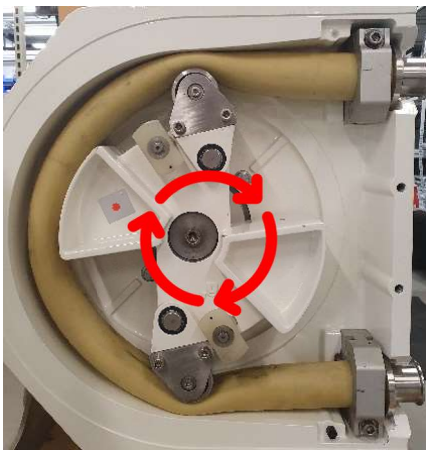

Clockwise

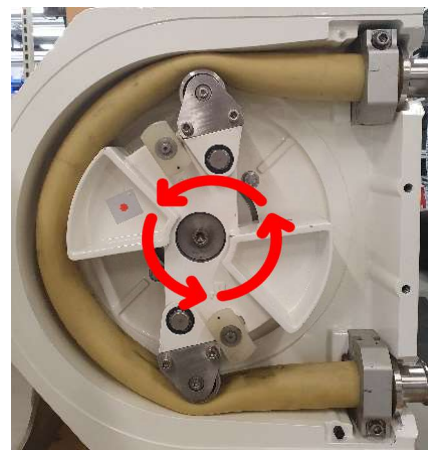

Anti-clockwise

13 Cleaning

13.1 Safety

The pumphead door is opened and closed during the cleaning process to unlock/lock rocker assemblies. The pumphead features a proximity sensor, which when connected to a control system can function as an emergency stop in safety applications up to category 1, SIL 1 as defined by ISO 13849-1, IEC 62061.

It is recommended that an evaluation/assessment is carried out to confirm the level of functional safety required.

If in doubt, a safety shutdown method should always be used.

13.2 Clean In Place (CIP)

When using a clockwise pumping direction and unlocked rockers, no adjustment is required.

If rockers are locked for bi-directional pumping, as detailed at chapter 12.2.1.5.

1. Unlock one rocker assembly (see chapter 11.2.2.1 figure 1)
2. Rotate rotor anticlockwise until no tube occlusion by closing and locking the Pumphead door and operating the pump.
3. Free flow of cleaning agent is now possible.



Before re-starting and operating the pump, ensure rocker assemblies are in the correct position for operation.



Rocker assemblies shown locked for bi-directional pumping

13.3 Steam In Place (SIP)

SIP can be carried out on the 800 series at a maximum of 135°C (275°F) for a maximum of 30 minutes at 2 bar. Normal operation of the pump with roller occlusion of tube element only allows 80°C (175°F) maximum temperature for fluid.

The higher temperature classification applies only to sterilisation and cleaning with the pump not operating and rollers disengaged from element (see chapter 11.2.2.2)

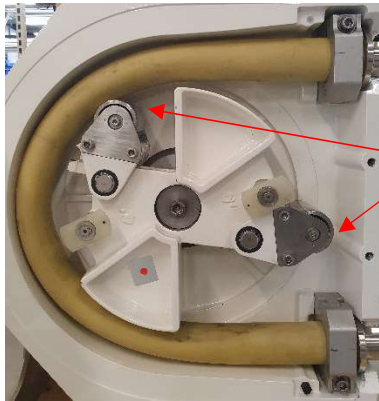

No tube occlusion of tube element,
Pump not in operation

A minimum 1 m safety area is to be observed during the process to avoid possible scalding if a tube burst occurs. Monitor the process continuously.



CAUTION

Ensure pumphead door is closed and tool locked before SIP cleaning and general operation. The exterior of the pump can get hot during operation. Stop the pump and let cool before handling

Ensure a 15-minute acclimatisation period is observed after SIP process.

Before re-starting and operating the pump, ensure rocker assemblies are in the correct position for operation.

14 Maintenance

14.1 Spare parts

The table below provides a list of spare parts which may be used during installation, servicing, or maintenance.

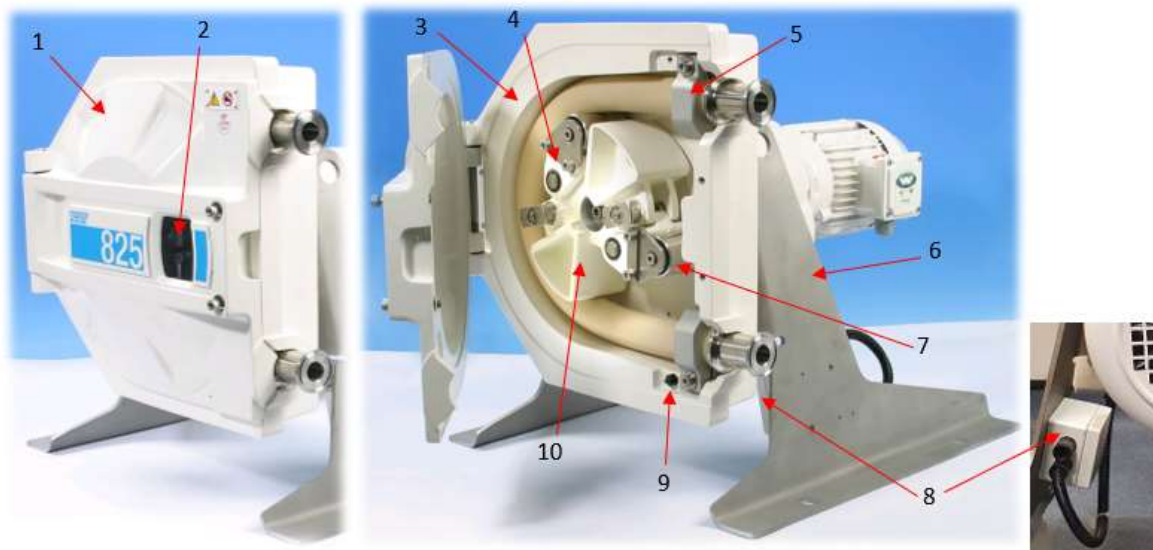

Parts

Item	Description	Model	Part number	Model	Part number
1	Door	825	HF1202C	840	HF1402C
2	Window	825	HF1005S	840	HF1005S
3	Track	825	HF1201C	840	HFZ8063T
4	Rocker Assembly	825	HFA1205A	840	HFA1405A
5	Tube Clamp	825	HFA1201A	840	HFA1401A
6	Frame Support RH	825	HF1271S	840	HF1467S
	Frame Support LH	825	HF1272S	840	HF1468S
7	Roller Assembly	825	HF1204A	840	HFA1404A
8	Terminal Box	825	HFA1202A	840	HFA1202A
9	Proximity Sensor	825	SWZ8007	840	SWZ8007
10	Rotor Assembly	825	HFA1206A	840	HFA1406A

Connectors



Item	Description	Model	Part number
1	Triclamp Hygienic connector	825	089.0250.00T
2	SMS Hygienic connector	825	089.0250.00S
3	Quick Coupling	825	089.0250.00Q



Item	Description	Model	Part number
1	Triclamp Hygienic connector	840	089.0400.00T
2	SMS Hygienic connector	840	089.0400.00S

Tubing

Description	Model	Part number
825TM 2 bar Bioprene tube element	825	088.T250.E0P
825TM 2 bar Bioprene tubing 2.3m length	825	089.T250.00P
825TH 3.5 bar Bioprene tube element	825	089.0250.E0G
825TH 3.5 bar Bioprene tubing 2.3m length	825	089.1250.00G
825TS STA PURE high pressure tube element	825	089.1250.000
840TM 2 bar Bioprene tube element	840	088.T400.E0P
840TH 3.5 bar Bioprene tube element	840	088.T400.E0G

14.2 Drive maintenance: restricted maintenance (EP)

14.2.1 Gearbox

For gearbox maintenance refer to the manufacturer's instructions.

14.2.2 Motor and motor mounted inverter

There are no replaceable or serviceable parts within the motor or motor mounted inverter. If either of these drive components are damaged, remove the pump from service and contact your Watson-Marlow representative to discuss how the pump can be repaired.

Do not attempt to repair the motor or motor mounted inverter. This is restricted maintenance to be undertaken by the motor or motor mounted inverter manufacturer

14.3 Pumphead maintenance

14.3.1 Tubing

The tubing element installed in the pumphead is a primary consumable item.

14.3.1.1 Life of tubing

It is not possible for Watson-Marlow to predict the precise life of a tubing element due to factors such as speed, chemical compatibility, temperature, and pressure.

The following are an indication that the tubing element is near its end of life:

- Flowrate drops from its normal rate of flow at a given rpm
- Pumphead begins to allow fluid to leak past it when stopped.

14.3.1.2 Tubing removal and replacement

1. Isolate from power supply
2. Isolate fluid path
3. Disconnect tubing element from fluid path



WARNING

Risk of serious injury, death and damage to equipment or property from chemical spillage. Harmful chemicals maybe spilled when disconnecting the fluid path from the tubing element. Follow your organisations procedures such as the wearing of suitable PPE and draining procedures.

Refer to Figure 1 when rocker assemblies are to be locked or unlocked

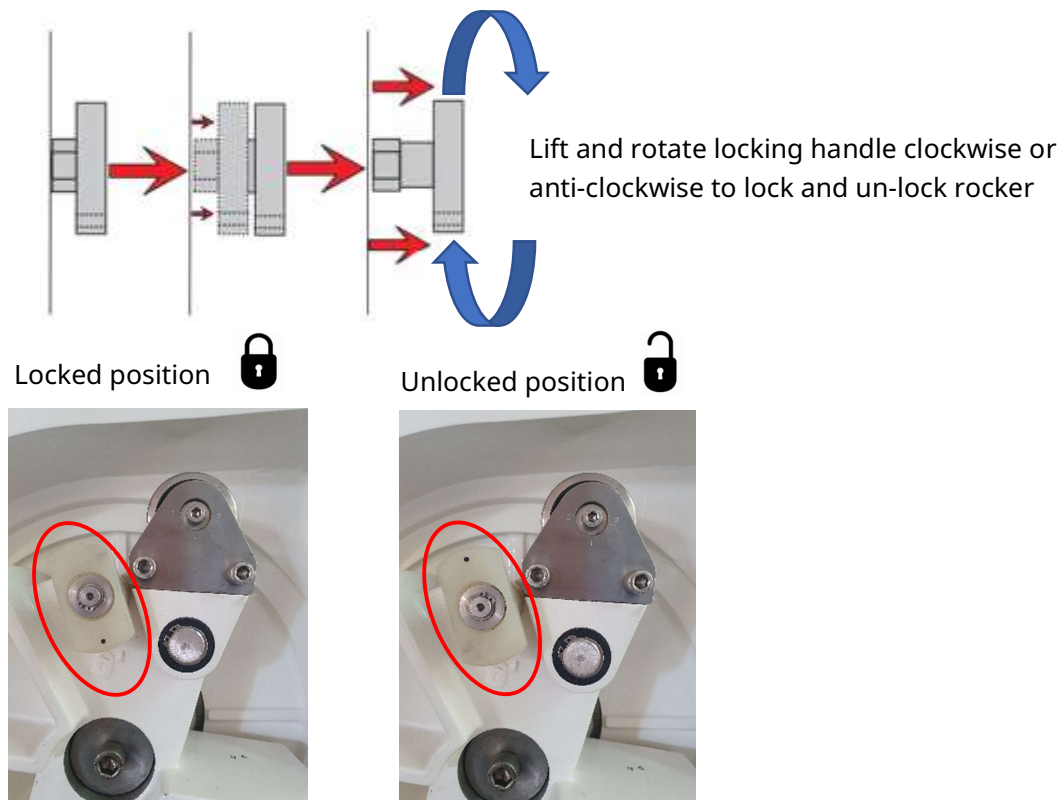

Figure 1

Refer to Figure 2 when rotor assembly requires rotating.



CAUTION

The rotor must only be rotated using the recesses as shown to prevent crushing/trapping injuries or cuts and abrasions

Figure 2

Refer to Figure 3 when rocker assemblies are moved.



CAUTION

Never place hands on outer edge of rotor near the rocker assemblies or rocker pin to prevent crushing/trapping injuries or cuts and abrasions

Figure 3



4. Open pumphead door and unlock rocker assembly not in contact with tubing (refer to Figure 1).
5. Close and secure pumphead door and reconnect power supply. Power up and rotate anti-clockwise until unlocked rocker (**1**) is disengaged and rests against the tube.



6. Unlock lower tube clamp and remove tubing from around rotor and drain excess fluid.



WARNING

Risk of serious injury or death and equipment or property damage from a chemical spillage. Harmful chemicals may remain in the tubing element. Follow your organisations procedures such as the wearing of suitable PPE and draining procedures.



CAUTION

Care is to be taken when couplings are released from either clamp as movement of heavy coupling can cause impact or striking injuries, abrasions, and cuts.

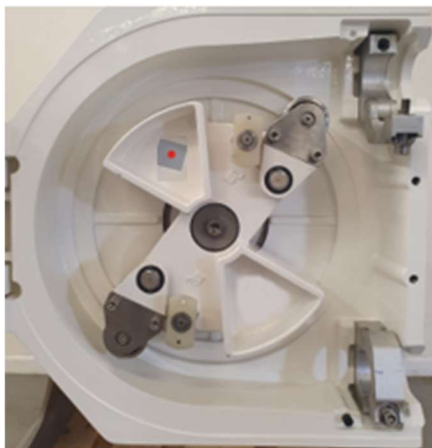

7. Unlock upper tube clamp and remove tubing.
8. Clean pumphead door, track surface and lock the unlocked rocker assembly (refer to Figure 1).

14.3.1.3 Constructing a tubing element

Insert a coupling into both ends of a new section of tubing as shown below, ensuring that the coupling butts against the element end



14.3.1.4 Install a tube element

Preparation

To install a tube element, use the following procedure:

1. Ensure the drive is isolated from power supply.
2. Check that upper and lower tube clamps **(1)** are open

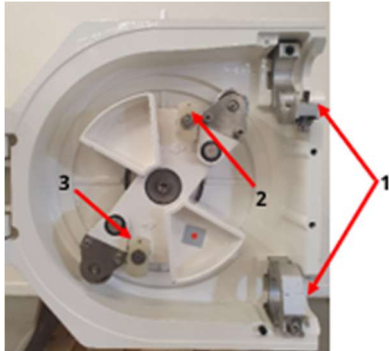

3. Rotate rotor to position shown using casting recesses (refer to figure 2)



CAUTION

The rotor must only be rotated using the recesses as shown to prevent crushing/trapping injuries or cuts and abrasions

4. Check that lower rocker assembly **(3)** is locked in engaged position.
5. Unlock upper rocker assembly **(2)** (refer to figure 1).



6. Holding roller-mount **(4)** as shown, pull rocker assembly **(5)** clear of locking pin **(6)**.

CAUTION



Never place hands on outer edge of rotor near the rocker assemblies or rocker pin to prevent crushing/trapping injuries or cuts and abrasions

7. Turn locking pin assembly (6) to locked position (refer to figure 1).
8. Gently allow rocker assembly (5) to return until it rests on locking pin assembly (6)
9. The rocker assembly is now disengaged and free to retract when rotating the rotor anti-clockwise during tube element loading.



14.3.1.5 Installing the tube element

1. Locate tube coupling into upper clamp, ensuring coupling sits correctly in track groove then hand tighten clamp.

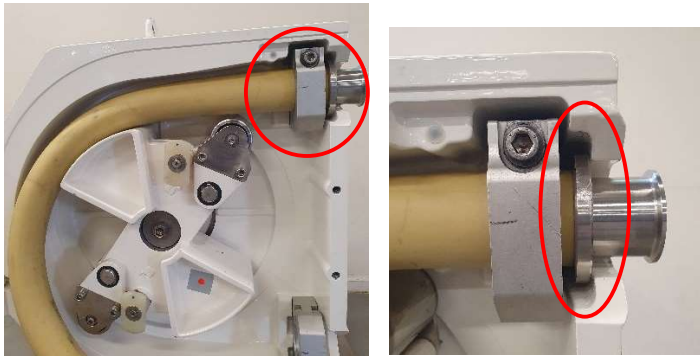

CAUTION

Ensure that coupling is locked into clamp before bending tube. Movement can cause, Impact or striking injuries, abrasions, and cuts.

2. Feed tubing into track whilst rotating rotor anti-clockwise using the casting recesses



CAUTION

The rotor must only be rotated using the recesses as shown to prevent crushing/trapping injuries or cuts and abrasions

3. Slowly rotate anti-clockwise until lower tube coupling is located into the lower clamp (1) ensuring coupling sits correctly in track groove then hand tighten clamp.
4. The locked, disengaged rocker assembly (2) should be in position shown.
5. The rotor is prevented from rotating further by the locked, engaged rocker assembly (3)

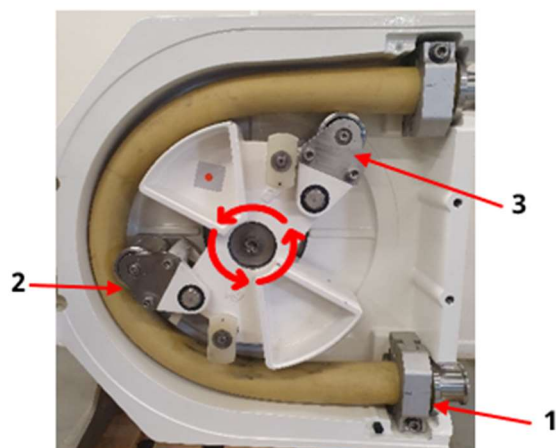

6. Securely fasten upper and lower clamps.
7. Once tube is secured, the lower rocker assembly (2) will be held in the retracted position by the tube.
8. Rotate rocker locking pin assembly to the unlocked position (refer to figure 1)
9. This allows rocker assembly (2) to return to the engaged position when rotor is rotated.
10. Because the upper rocker assembly (3) is locked, and engaged, it will not be possible to rotate the rotor by hand.
11. To engage the lower rocker assembly (2) it is necessary to rotate the rotor with power on.
12. Close and secure the pumphead door and reconnect power supply
13. Turn on the drive and rotate rotor clockwise until the unlocked rocker assembly is engaged in position (audible sound when this happens)
14. Isolate the drive from power supply and open the pumphead door.

15. Rotate locking pin assembly into the locked position (refer to figure 1)



16. Check that both rocker assemblies are locked into the engaged pumping position

17. Close the pumphead door and tool tighten door screws.

On completion.

1. Reconnect fluid path
2. Remove fluid path isolation
3. Bring pump back into service and check for leaks

14.3.2 Roller adjustment

Roller adjustment maybe required if the recommended tube element is not used, or pump performance does not appear optimal.

Contact your Watson-Marlow representative for guidance.

15 Troubleshooting

15.1 Troubleshooting

15.1.1 Troubleshooting table

Should the pump fail to operate, carry out the following checks as a quick reference. Also refer to the drive/inverter manufacturers manuals for further information.

Problem	Possible Cause	Action
Failure to start	Insufficient power from drive	Check that drive rating is correct
		Check drive operates independently from Pumphead.
		Replace/repair drive as required
Reduced fluid path flow or pressure	Fluid path valves closed	Open valves to correct position
	Occlusion insufficient	Check occlusion setting of rollers
	Fluid element damaged	Check occlusion setting of rollers Check that correct element is in use Replace element
	Blockage of fluid element or tubing	Clear element and fluid tubing and flush system
	Inlet fluid path too small	Increase diameter of tubing
	Compatibility of fluid	Check compatibility of fluid as viscosity may change with temperature
	Fluid element not airtight	Check all connectors are correctly fitted
Pump temperature high	Pump speed too high	Reduce pump speed
	Poor fluid flow	Check fluid path for blockages
	Fluid temperature high	Check compatibility of fluid

Problem	Possible cause	Action
Vibration	Pump speed to high	Reduce pump speed
	Pump not secured	Secure pump to mounting correctly
	Fluid path tube bore insufficient	Use larger bore tubing in fluid path
	Fluid path not secured	Secure fluid path correctly.
Short element life	Chemical compatibility	Check compatibility of fluids including any cleaning agents used
	Occlusion of element incorrect	Check occlusion setting of rollers.
	Pump speed to high	Reduce pump speed
	High pressure operation	Reduce operating pressure

15.2 Technical support

Should you be unable to resolve the error or breakdown, or have another query please contact us your Watson-Marlow representative for technical support.

15.2.1 Manufacturer

This product is manufactured by Watson-Marlow. For guidance or support of this product please contact:

Watson-Marlow Limited
 Bickland Water Road
 Falmouth, Cornwall
 TR11 4RU
 United Kingdom

Phone : +44 1326 370370

Website : <https://www.wmfts.com/>

15.3 Warranty

Watson-Marlow Limited ("Watson-Marlow") warrants this product to be free from defects in materials and workmanship for two years from the date of shipment, under normal use and service.

Watson-Marlow's sole responsibility and the customer's exclusive remedy for any claim arising out of the purchase of any product from Watson-Marlow is, at Watson Marlow's option: repair, replacement, or credit, where applicable.

Unless otherwise agreed in writing, the foregoing warranty is limited to the country in which the product is sold.

No employee, agent or representative of Watson-Marlow has the authority to bind Watson-Marlow to any warranty other than the foregoing unless in writing and signed by a director of Watson-Marlow. Watson-Marlow makes no warranty of the fitness of its products for a particular purpose.

In no event:

- i. shall the cost of the customer's exclusive remedy exceed the purchase price of the product.
- ii. shall Watson-Marlow be liable for any special, indirect, incidental, consequential, or exemplary damages, however arising, even if Watson-Marlow has been advised of the possibility of such damages.

Watson-Marlow shall not be liable for any loss, damage, or expense directly or indirectly related to or arising out of the use of its products, including damage or injury caused to other products, machinery, buildings, or property. Watson-Marlow shall not be liable for consequential damages, including, without limitation, lost profits, loss of time, inconvenience, loss of product being pumped, and loss of production.

This warranty does not obligate Watson-Marlow to bear any costs of removal, installation, transportation, or other charges which may arise in connection with a warranty claim.

Watson-Marlow shall not be responsible for shipping damage of returned items.

15.3.1 Conditions

- Products must be returned by pre-arrangement to Watson-Marlow, or a Watson-Marlow approved service centre.
- All repairs or modifications must have been made by Watson-Marlow Limited, or a Watson-Marlow approved service centre or with the express permission in writing of Watson-Marlow, signed by a manager or director of Watson-Marlow.
- Any remote control or system connections must be made in accordance with Watson-Marlow recommendations.
- All PROFIBUS systems must be installed or certified by a PROFIBUS approved installation engineer.

15.3.2 Exceptions

- Consumable items including tubing and pumping elements are excluded.
- Pumphead rollers are excluded.
- Repairs or service necessitated by normal wear and tear or by lack of reasonable and proper maintenance are excluded.
- Products which, in the judgement of Watson-Marlow, have been abused, misused, or subjected to malicious or accidental damage or neglect are excluded.
- Failure caused by electrical surge is excluded.
- Failure caused by incorrect or sub-standard system wiring is excluded.
- Damage by chemical attack is excluded.
- Ancillaries such as leak detectors are excluded.
- Failure caused by UV light or direct sunlight.
- Any attempt to disassemble a Watson-Marlow product will invalidate the product warranty.

Watson-Marlow reserves the right to amend these terms and conditions at any time.

15.4 Returning pumps

Contact your Watson-Marlow representative before a product return.

Before returning products, they must be thoroughly cleaned/decontaminated. The declaration confirming this must be completed and returned to us in advance of the item being shipped.

You are required to complete and return a decontamination declaration stating all fluids that have been in contact with the equipment being returned to us.

On receipt of the declaration, a Returns Authorisation Number will be issued. Watson-Marlow reserves the right to quarantine or refuse any equipment that is not displaying a Returns Authorisation Number.

Please complete a separate decontamination declaration for each product and use the correct form that denotes the location you wish to return the equipment to.

A copy of the appropriate decontamination declaration can be downloaded from the Watson-Marlow website at <https://www.wmfts.com/decon/>

If you have any queries, then please contact your local Watson-Marlow representative for further assistance at www.wmfts.com/contact.

16 Chemical compatibility

Ensuring chemical compatibility is a key requirement in determining if the pumped fluid and the chemical environment the pump is operating in, is within scope of the intended use of the product.

Chemical compatibility analysis is based on which materials of construction would be in contact (wetted) with the fluid or environment, as represented by the 3 scenarios in this table

A	B	C
Fluid Path (wetted by the pumped fluid in normal use)	Potential of being wetted due to environment or spillage	Potential of being wetted due to operating the tubing element to the point of failure
These materials of construction will come into contact with the process fluid during intended use	These materials of construction could become wetted due to a chemical spillage, cleaning or the environment the pump is operating in	These materials of construction will come into contact if the pumphead is operated to the point of failure
Pumphead: Fluid path <ul style="list-style-type: none"> • Tubing • Tubing connectors Process: Fluid path <ul style="list-style-type: none"> • Tubing connector seals • Process pipework and connections to tubing element 	Pumphead ¹ : <ul style="list-style-type: none"> • Pump casework • Support Frame 	Pumphead ¹ : <ul style="list-style-type: none"> • Pump casework • Support Frame

NOTE ¹

The pumphead is not sealed to the drive. The air of the environment in which the pump is operating can circulate between the pumphead and the drive (pumphead to drive interface area).

16.1 How to check chemical compatibility

Follow the individual procedures to check chemical compatibility for each of the 3 scenarios:

16.1.1 Scenario A: Fluid Path (wetted by the pumped fluid in normal use)

Check the chemical compatibility of scenario A: Fluid Path (wetted by the pumped fluid in normal use) using this procedure:

Procedure

Navigate to

<https://www.wmfts.com/en/support/chemical-compatibility-guide/>

1. Search for the fluid or select from the list
2. Check the fluid is compatible with the material of the following
 - pumphead tubing material
 - pumphead tubing connector material
 - pumphead tubing connector seals
 - process fluid path pipework

16.1.2 Scenario B: Potential of being wetted due to environment or spillage

If the pump will be exposed to chemicals, due to spillage or the environment the pump is operating in (for example corrosive gases), then the materials of construction in table at 16.1.2.1 (below) should be checked for chemical compatibility using standard engineering chemical compatibility guides:

16.1.2.1 Materials of construction: Potential of being wetted due to environment or spillage

Description	Material
Pumphead body, door, and rotor	Aluminium (Epoxy polyester powder coated)
Rollers and connectors	Stainless Steel 316
Frame	Stainless Steel 304
Door and motor fixings	High Tensile Steel
Frame Fixing	Stainless Steel
Rocker Locking Knob 840	Polypropylene
Rocker Locking Knob 825	Stainless Steel

16.1.3 Scenario C: Potential of being wetted due to operating the tubing to the point of failure

The pump should not be operated to the point of tubing failure.

Operating the pump to the point tubing failure, will result in chemicals coming into contact with parts/materials which would not normally be wetted by the pumped fluid.

If there is risk in a user's organisation that the pump would be operated to the point of tubing failure, or if the point of tubing failure cannot be monitored, then a check of chemical compatibility of the materials of construction that have the potential of being wetted when the tube or fluid contacting element fails (see table 16.1.3.1 below) should be undertaken using standard engineering chemical compatibility guides.

16.1.3.1 Materials of construction that have the potential of being wetted when the tube fails

Description	Material
Pumphead body, door, and rotor	Aluminium (Epoxy polyester powder coated)
Rollers and connectors	Stainless Steel 316
Frame	Stainless Steel 304
Door and motor fixings	High Tensile Steel
Frame Fixing	Stainless Steel
Rocker Locking Knob 840	Polypropylene
Rocker Locking Knob 825	Stainless Steel

17 Product specification and equipment ratings

17.1 Physical

17.1.1 Performance

17.1.1.1 speed and flowrate

Flowrates are based on pumping water at 20 °C nominal, with a 0 bar.g inlet and discharge pressure.

825

Drive (kw)	RPM	L/HR	US GPH
0.37	08	162	42.7
	10	196	51.7
0.55	13	260	68.6
	17	327	86.3
	21	412	108.8
	26	507	133.9
	28	563	148.7
	33	658	173.8
0.75	36	721	190.4
	40	796	210.2
	47	933	246.4
1.1	53	1050	277.3
	59	1169	308.8
	67	1327	350.5
1.1	74	1474	389.3
	84	1672	441.6
	90	1787	472.0
	104	2060	544.1

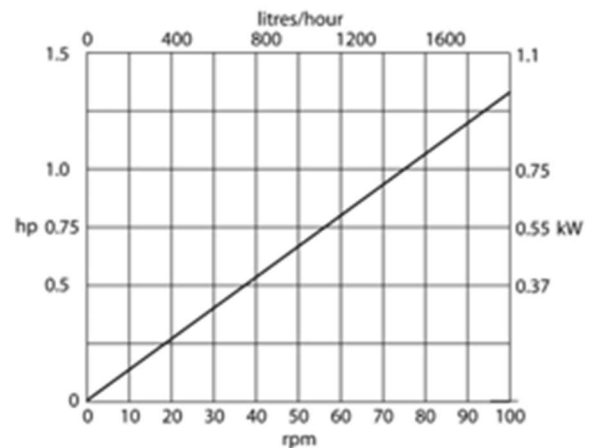

840

Drive (KW)	RPM	L/HR	US GPH
0.55	08	653	172.5
	10	790	208.6
	13	1045	276.0
	16	1277	337.3
0.75	22	1756	463.8
	25	1995	527.0
1.1	29	2314	611.2
	33	2647	699.2
	36	2905	767.4
	42	3352	885.5
1.5	47	3751	990.9
	52	4150	1096
	58	4628	1222
	65	5187	1370
2.2	73	5825	1538
	79	6304	1665
	89	7102	1876
3	102	8140	2150

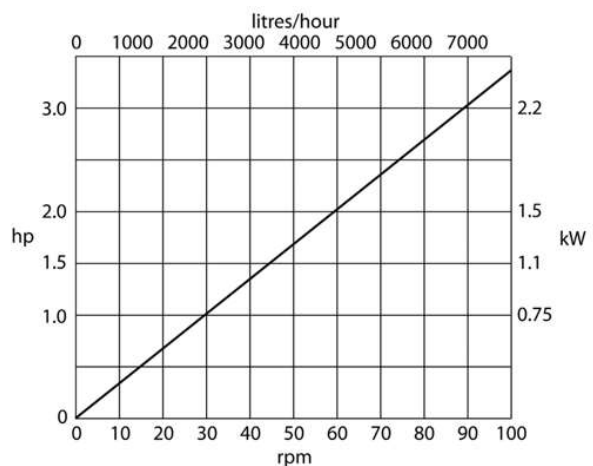

17.1.2 Environmental and operating conditions

	Pumphead and support (SP)	Engineered Product (EP)
Ambient temperature range	5 °C to 40 °C (40°F to 105°F)	Refer to drive instructions
Maximum altitude	≤2000 m, (6561 ft)	Refer to drive instructions
Pollution degree of the intended environment	2	Refer to drive instructions
Noise	<75 dB(A) at 1 m	Refer to drive instructions
Maximum fluid temperature ¹	80°C (175°F)	
Environment	Indoor	Refer to drive instructions

NOTE ¹

Chemical compatibility is dependent on temperature. A procedure for checking chemical compatibility is provided at Section 16.

17.1.3 Dimensions

825

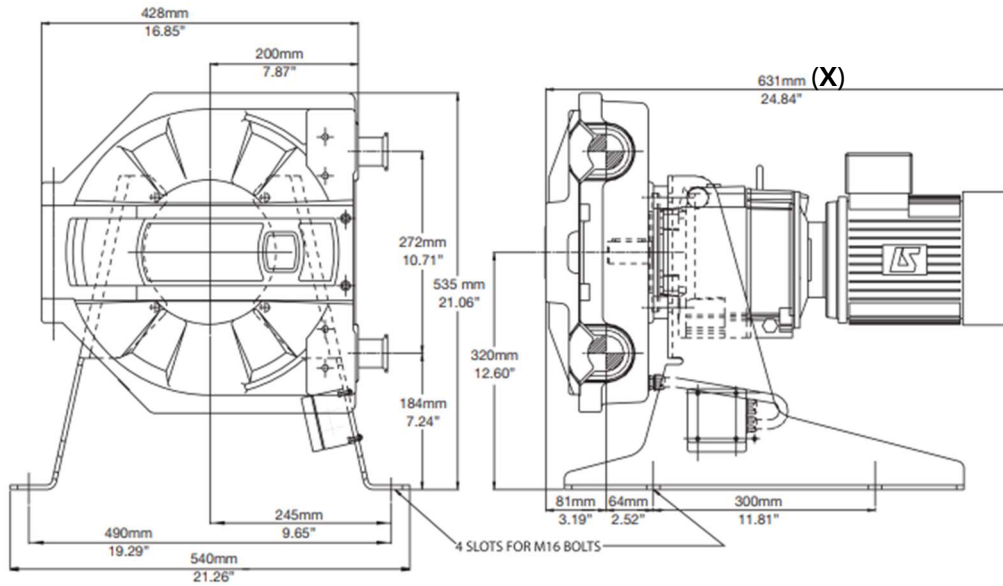

840

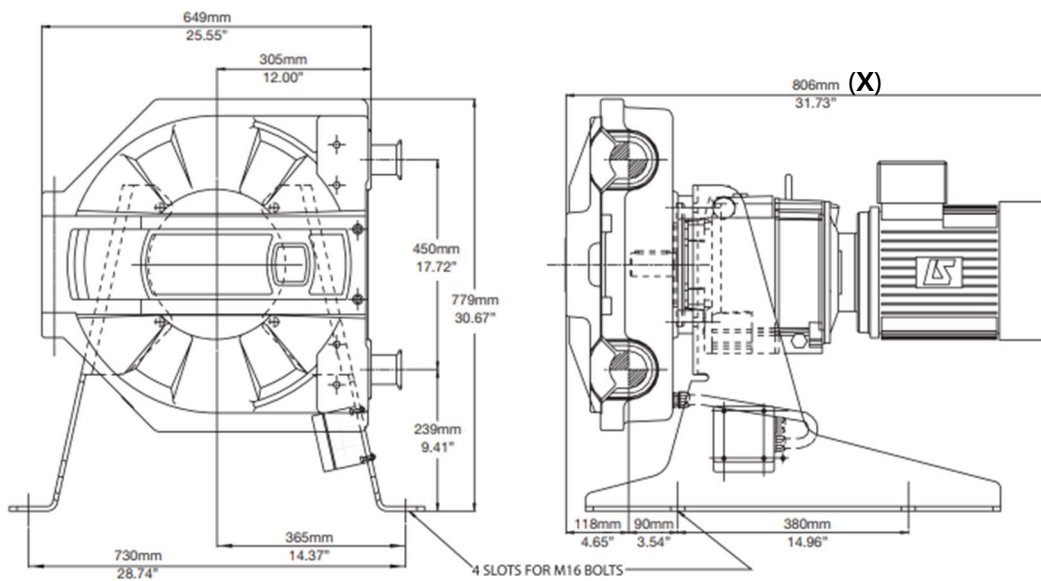

Dimension (X) is dependent on the drive variation fitted

17.1.4 Weight

Nominal weight of Pumps	
825 Series	840 Series
100 kg (220 lb)	175kg (385 lb)

17.1.5 Ingress protection (IP Rating)

Pumphead and support (SP)

No IP rating

Pumphead, support and drive (EP)¹

The IP rating of the drive is dependent upon the drive and inverter which is fitted. IP55 is standard with an option for IP66.