

Bredel 40

Bredel hose pumps (10-50)

Features and benefits

- Dry running and self-priming
- Suction capability up to 9.5 mWC (374 inWC)
- No seals, ball-checks, diaphragms, glands, immersed rotors, stators or pistons to leak, clog, corrode or replace
- Handles abrasive slurries, corrosive acids, gaseous liquids
- No slippage, allowing true positive displacement for accurate and repeatable metering
- No ancillary equipment, check valves, sealing water flush systems or run-dry protection required
- Fully reversible to blow out suction and drain lines safely



Bredel 40 performance

Bredel 40

Required motor power kW (hp)

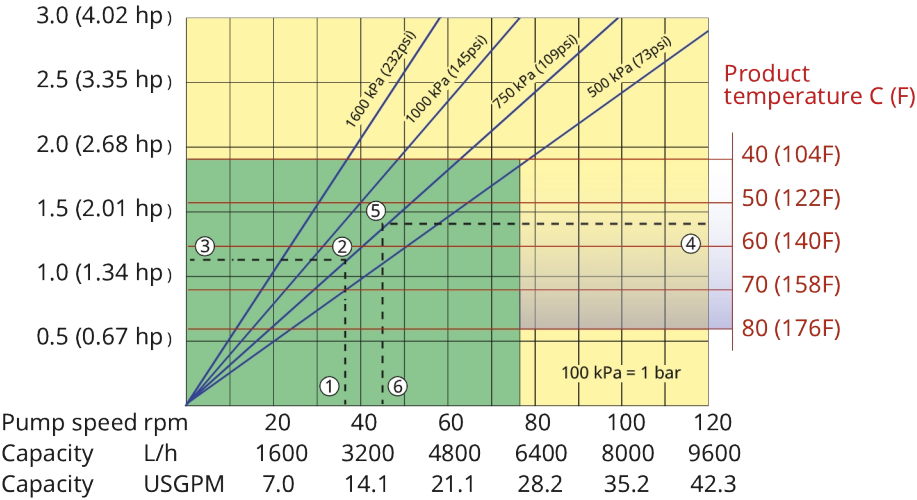

Note: The area of continuous operation diminishes with increased product temperatures. For product temperatures >40C, the area of continuous operation reduces to the corresponding red temperature line.

1. Flow required indicates pump speed
2. Calculated discharge pressure
3. Net motor power required
4. Product temperature
5. Calculated discharge pressure
6. Maximum recommended pump speed

- Continuous duty
- Intermittent duty

* Maximum 3 hours operation followed by minimum 1 hour stop

Technical specifications

	Bredel 40
Max. flow rate continuous	5985 L/h
Max. flow rate continuous	1579 USGPH
Max. flow rate intermittent	9576 L/h
Max. flow rate intermittent	2527 USGPH
Volume per revolution	1.33 L
Volume per revolution	0.35 USG
Max. continuous operating speed	75 rpm
Max. intermittent operating speed	120 rpm
Max. operating pressure	16 bar
Max. operating pressure	232 psi
Max. inlet pressure	2.5 bar abs
Max. inlet pressure	38 psi abs
Max. suction capability	9.5 mWC
Max. suction capability	374 inWC
Suction capability (80% Flow rate)	9 mWC
Suction capability (80% Flow rate)	354 inWC
Operating temperature range	-20 to 45 °C
Operating temperature range	-4 to 113 °F
Fluid temperature range	-20 to 80 °C
Fluid temperature range	-4 to 176 °F
Min. starting torque	320 N m
Min. starting torque	2832 in.lbs
Weight	180 kg
Weight	397 lbs
Hose lubricant required	5 L
Hose lubricant required	1.32 USG
Port configurations	Down, Left, Right, Up
Compatible hose materials	CSM, EPDM, F-NBR, NBR, NBR for food, NR-Metering, NR-Transfer
Compatible tube materials	Bioprene
Flange assembly type	ANSI, DIN, JIS

Please consult your Bredel representative for lower or higher temperature operation.

Allowable ambient temperature is based on pump capabilities and may be further limited by gearbox ambient capabilities.

Materials of construction

	Bredel 40
Hose material	Bioprene (tube), CSM, EPDM, F-NBR, NBR, NBR for food, NR-Metering, NR-Transfer
Housing	Cast iron, ISO12944 category C4M
Rotor assembly	Cast iron, ISO12944 category C4M
Cover assembly	Cast iron, ISO12944 category C4M
Brackets and fasteners	Galvanized steel, Stainless steel 316
Support frame	Galvanized steel, Stainless steel 316
Hose clamps	Galvanized steel, Stainless steel 316
Seals	Neoprene, Nitrile

Bredel 40 dimensions

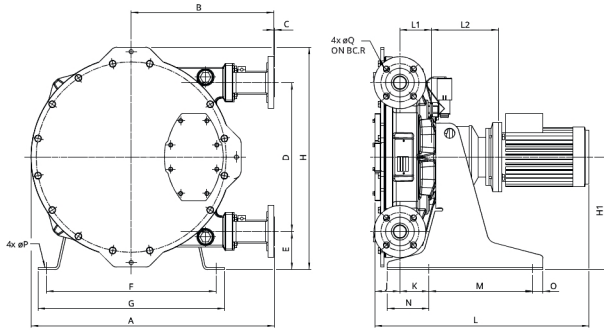

Type	A	B	C	D	E	F	G	H	H1	J	K	Lmax	L1	L2max	M	N	O	ØP	ØQ	R
Bredel 40 (mm)	705	412	2.5	430	110	490	540	643	325	73	84	906	91	301	300	120	30	18	18	110
Bredel 40 (inches)	27.8	16.2	0.09	16.9	4.3	19.3	21.3	25.3	12.8	2.9	3.3	35.7	3.6	11.9	11.8	4.7	1.2	0.71	0.71	4.3
Connector sizes							ANSI 150#						EN DIN				JIS			
Bredel 40							1.5"						40mm				40mm			

Disclaimer: The information contained in this document is believed to be correct at the time of publication, but Watson-Marlow Bredel BV accepts no liability for any error it contains, and reserves the right to alter specifications without prior notice. All mentioned values in this document are values under controlled circumstances at our test bed. Actual flow rates achieved may vary because of changes in temperature, viscosity, inlet and discharge pressures and/or system configuration. APEX, DuCoNite, Bioprene and Bredel are registered trademarks.

wmfts.com/global



23 November 2023